

THIS DRAWING IS UNPUBLISHED.

RELEASED FOR PUBLICATION

© COPYRIGHT - TE Connectivity Ltd.

ALL RIGHTS RESERVED.

REVISIONS

P	LTR	DESCRIPTION	DATE	DWN	APVD
	J3	REVISED PER ECO-18-010831	13JUL2018	RS	JO

NOTES:

- 1 FOR MINI-APPLICATOR-CRIMPING.
- 2 UNDERCOATING: 1,25µm Ni, SELECTIVE: 0,8µm Au, ZONE 1: 0,5µm MIN. GOLDFLASH.
- 3 UNDERCOATING: 1,25µm Ni, SELECTIVE: 0,8µm Au, REMAINDER: GOLDFLASH.
- 4 UNDERCOATING: 1,25µm Ni, SELECTIVE: 0,4µm Au, NO GOLDFLASH.
- 5 UNDERCOATING: 1,25µm Ni, SELECTIVE: 2,0µm Au, REMAINDER: GOLDFLASH.
- 6 PRE-TIN PLATED: 2,0µm.
- 7 ZONE 1: BRIGHT TIN/LEAD PLATED.
- 8 MATERIAL: PHOSPHORBRONZE
- 9 FOR STANDARD-APPLICATOR-CRIMPING.
- 10 FOR REELFED-HANDTOOL-CRIMPING.
- 11 24-20 AWG (0,20-0,56 mm²) WITH .055 CRIMPER.
26 AWG (0,12-0,14 mm²) WITH .042 CRIMPER.
- 12 OBSOLETE PARTS: OBSOLETE CIS STREAMLINING PER D.RENAUD/D.SINISI

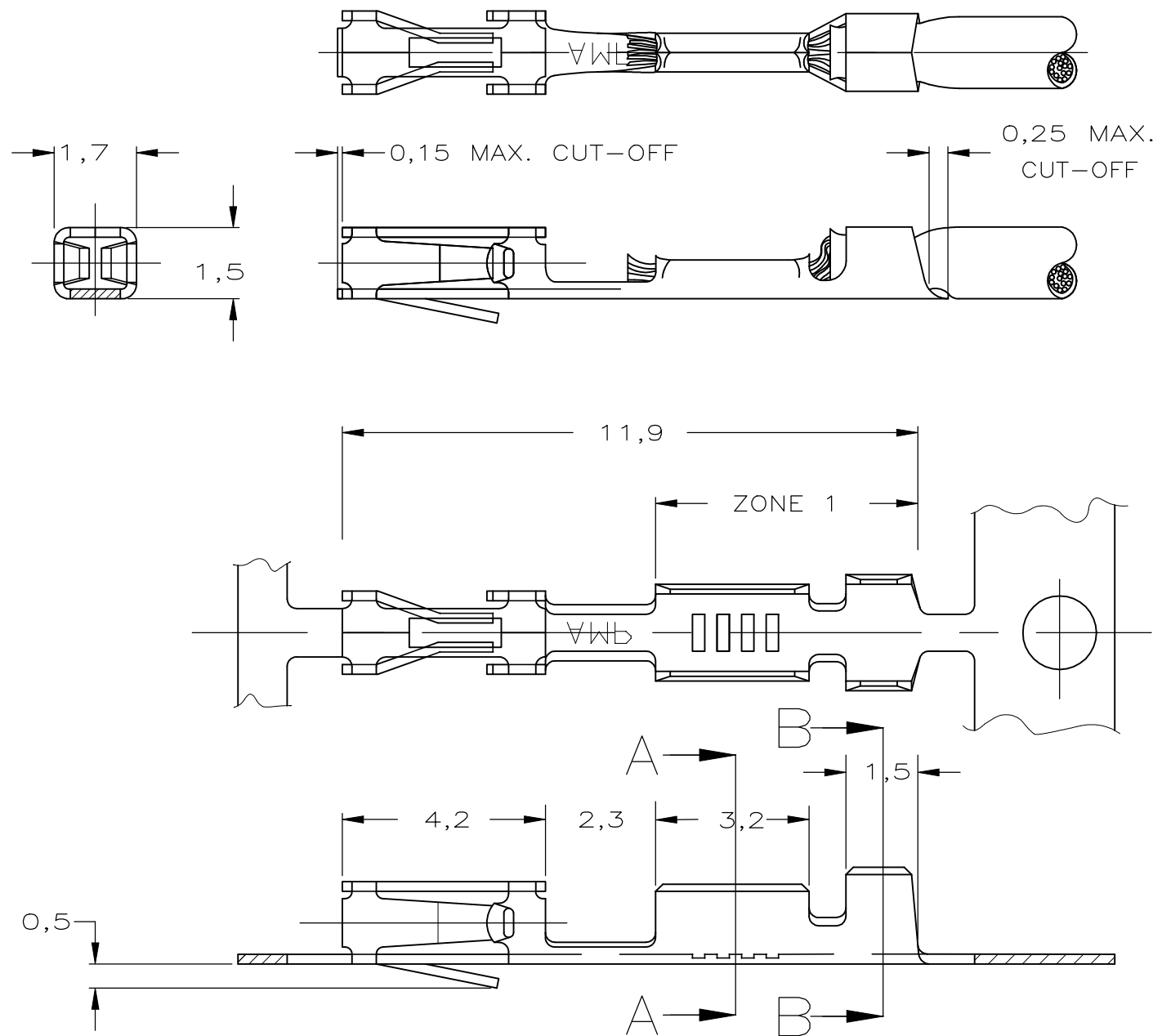

GOLD	2	1-141708-2	5-167301-4	12	10
TIN	6	1-141708-1	5-167301-2	12	10
GOLD	5	≠	2-167301-6	12	1
			2-167301-5		9
GOLD	2	1-141708-2	2-167301-4		1
			2-167301-3	12	9
TIN	6	1-141708-1	2-167301-2		1
			2-167301-1		9
GOLD	4	≠	1-167301-6		1
			1-167301-5		9
GOLD	3	141708-1	167301-4		1
			167301-3		9
		LOOSE PIECE	PART NUMBER		

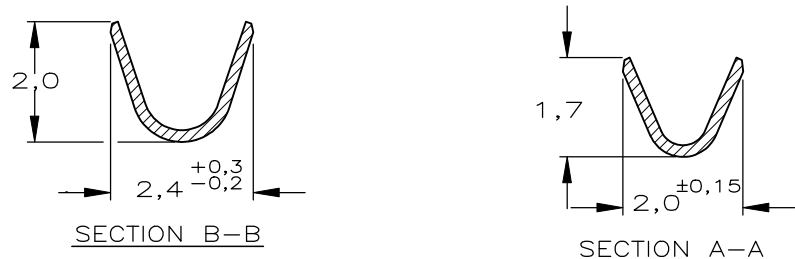

THIS DRAWING IS A CONTROLLED DOCUMENT.

DWN R.VISSER 11-11-87
CHK J.v.LIEMPT
APVD L.v.SOEST
PRODUCT SPEC
APPLICATION SPEC
WEIGHT

TE TE Connectivity Ltd.

NAME
AMP MODU MOD.4
RECEPTACLE,S.C.P.
STRIP

SIZE	CAGE CODE	DRAWING NO	RESTRICTED TO
A3	00779	167301	-

CUSTOMER DRAWING SCALE - SHEET 1 of 1 REV J3

WIRE RANGE	INSUL.RANGE	MATERIAL	FINISH
11	1,4 MAX.DIA.	-	-