

CA-IS384x High-Performance Reinforced Quad-Channel Digital Isolators

1 Key Features

- Signal Rate: DC to 150Mbps
- Wide Operating Supply Voltage: 2.5V to 5.5V
- Wide Operating Temperature Range: -40°C to 125°C
- No Start-Up Initialization Required
- Default Output High and Low Options
- High Electromagnetic Immunity
- High CMTI: $\pm 150\text{kV}/\mu\text{s}$ (Typical)
- Low Power Consumption (Typical):
 - 1.5mA per Channel at 1Mbps with 5.0V Supply
 - 6.6mA per Channel at 100Mbps with 5.0V Supply
- Precise Timing (Typical)
 - 12ns Propagation Delay
 - 1ns Pulse Width Distortion
 - 2ns Propagation Delay Skew
 - 5ns Minimum Pulse Width
- Isolation Rating up to 5.7kVrms (wide body package)
- Isolation Rating up to 7.5kVrms (extra wide body package)
- ESD: $\pm 8\text{kV}$ HBM
- Isolation Barrier Life: >40 Years
- Tri-state Outputs with ENABLE
- Schmitt Trigger Inputs
- RoHS-Compliant Packages
 - SOIC16 Wide Body
 - SOIC16 Extra Wide Body

2 Applications

- Solar Inverter
- Wind-Generated Electricity
- High Voltage Power Storage
- High Voltage Grid System
- EV Charging Station
- Medical Electronics

3 Description

The CA-IS384x devices are high-performance quad-channel digital isolators with precise timing characteristics and low power consumption. The CA-IS384x devices provide high electromagnetic immunity and low emissions, while isolating CMOS digital I/Os. All device versions have Schmitt

trigger input for high noise immunity. Each isolation channel consists of a transmitter and a receiver separated by silicon dioxide (SiO₂) insulation barrier. The CA-IS3840 device has all four channels in the same direction with output enable on the output side (B side), the CA-IS3841 device has three forward and one reverse-direction channels with output enable on both sides, the CA-IS3842 device has two forward and two reverse-direction channels with output enable on both sides. All devices have fail-safe mode option. If the input power or signal is lost, default output is low for devices with suffix L and high for devices with suffix H.

CA-IS384x devices has high insulation capability to handle noise and surge on a data bus or other circuits from entering the local ground and interfering with or damaging sensitive circuitry. High CMTI ability promises the correct transmission of digital signal. The CA-IS384x devices are available in 16-pin wide body SOIC packages. All products support insulation withstanding up to 5.7kVrms.

Device Information

| PART NUMBER | PACKAGE | BODY SIZE(NOM) |
|---------------------------------------|----------------|---------------------|
| CA-IS3840, CA-IS3841, CA-IS3842 | SOIC16-WB(W) | 10.30 mm × 7.50 mm |
| | SOIC16-WWB(WW) | 10.30 mm × 14.00 mm |

Simplified Channel Structure

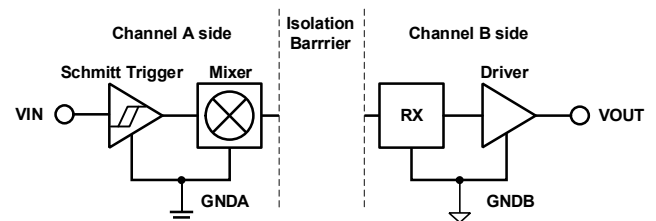

Channel A side and B side are separated by isolation capacitors. GND A and GND B are the isolated ground for signals and supplies of A side and B side respectively.

4 Ordering Guide

Table 4-1 Ordering Guide for Valid Ordering Part Number

| Ordering Part Number | Number of Inputs A Side | Number of Inputs B Side | Default Output | Isolation Rating (kV) | Output Enable | Package |
|----------------------|----------------------------|----------------------------|-------------------|--------------------------|------------------|------------|
| CA-IS3840LW | 4 | 0 | Low | 5.7 | Yes | SOIC16-WB |
| CA-IS3840HW | 4 | 0 | High | 5.7 | Yes | SOIC16-WB |
| CA-IS3841LW | 3 | 1 | Low | 5.7 | Yes | SOIC16-WB |
| CA-IS3841HW | 3 | 1 | High | 5.7 | Yes | SOIC16-WB |
| CA-IS3842LW | 2 | 2 | Low | 5.7 | Yes | SOIC16-WB |
| CA-IS3842HW | 2 | 2 | High | 5.7 | Yes | SOIC16-WB |
| CA-IS3840LWW | 4 | 0 | Low | 7.5 | Yes | SOIC16-WWB |
| CA-IS3840HWW | 4 | 0 | High | 7.5 | Yes | SOIC16-WWB |
| CA-IS3841LWW | 3 | 1 | Low | 7.5 | Yes | SOIC16-WWB |
| CA-IS3841HWW | 3 | 1 | High | 7.5 | Yes | SOIC16-WWB |
| CA-IS3842LWW | 2 | 2 | Low | 7.5 | Yes | SOIC16-WWB |
| CA-IS3842HWW | 2 | 2 | High | 7.5 | Yes | SOIC16-WWB |

Table of Contents

| | | | | | |
|----------|--|----------|-----------------|---|-----------|
| 1 | Key Features | 1 | 7.9.3 | $V_{DDA} = V_{DDB} = 2.5\text{ V} \pm 5\%$, $T_A = -40^\circ\text{C}$ to 125°C ... | 12 |
| 2 | Applications..... | 1 | 7.10 | Timing Characteristics | 13 |
| 3 | Description | 1 | 7.10.1 | $V_{DDA} = V_{DDB} = 5\text{ V} \pm 10\%$, $T_A = -40^\circ\text{C}$ to 125°C | 13 |
| 4 | Ordering Guide | 2 | 7.10.2 | $V_{DDA} = V_{DDB} = 3.3\text{ V} \pm 10\%$, $T_A = -40^\circ\text{C}$ to 125°C | 13 |
| 5 | Revision History | 3 | 7.10.3 | $V_{DDA} = V_{DDB} = 2.5\text{ V} \pm 5\%$, $T_A = -40^\circ\text{C}$ to 125°C | 14 |
| 6 | PIN Descriptions and Functions | 4 | 8 | Parameter Measurement Information | 15 |
| 7 | Specifications..... | 5 | 9 | Detailed Description | 17 |
| 7.1 | Absolute Maximum Ratings ¹ | 5 | 9.1 | Theory of Operation | 17 |
| 7.2 | ESD Ratings..... | 5 | 9.2 | Functional Block Diagram | 17 |
| 7.3 | Recommended Operating Conditions | 5 | 9.3 | Device Operation Modes | 18 |
| 7.4 | Thermal Information | 6 | 10 | Application and Implementation | 19 |
| 7.5 | Power Rating | 6 | 11 | Package Information | 20 |
| 7.6 | Insulation Specifications | 7 | 11.1 | 16-Pin Wide Body SOIC Package(10.30 mm × | |
| 7.7 | Safety-Related Certifications | 8 | 7.50 mm) | | 20 |
| 7.8 | Electrical Characteristics | 9 | 11.2 | 16-Pin Wide Body SOIC Package(10.30 mm × | |
| 7.8.1 | $V_{DDA} = V_{DDB} = 5\text{ V} \pm 10\%$, $T_A = -40^\circ\text{C}$ to 125°C | 9 | 14.00 mm) | | 21 |
| 7.8.2 | $V_{DDA} = V_{DDB} = 3.3\text{ V} \pm 10\%$, $T_A = -40^\circ\text{C}$ to 125°C | 9 | 12 | Soldering Information | 22 |
| 7.8.3 | $V_{DDA} = V_{DDB} = 2.5\text{ V} \pm 5\%$, $T_A = -40^\circ\text{C}$ to 125°C | 9 | 13 | Tape And Reel Information | 23 |
| 7.9 | Supply Current Characteristics | 10 | 14 | Important Notice | 24 |
| 7.9.1 | $V_{DDA} = V_{DDB} = 5\text{ V} \pm 10\%$, $T_A = -40^\circ\text{C}$ to 125°C | 10 | | | |
| 7.9.2 | $V_{DDA} = V_{DDB} = 3.3\text{ V} \pm 10\%$, $T_A = -40^\circ\text{C}$ to 125°C .. | 11 | | | |

5 Revision History

| Revision Number | Description | Page Changed |
|-----------------|---|--------------|
| Version 1.00 | N/A | N/A |
| Version 1.01 | Updated UL certification information | 8 |
| Version 1.02 | Updated UL, TUV certification information | 8 |
| Version 1.03 | Updated Isolated information | 7 |

6 PIN Descriptions and Functions

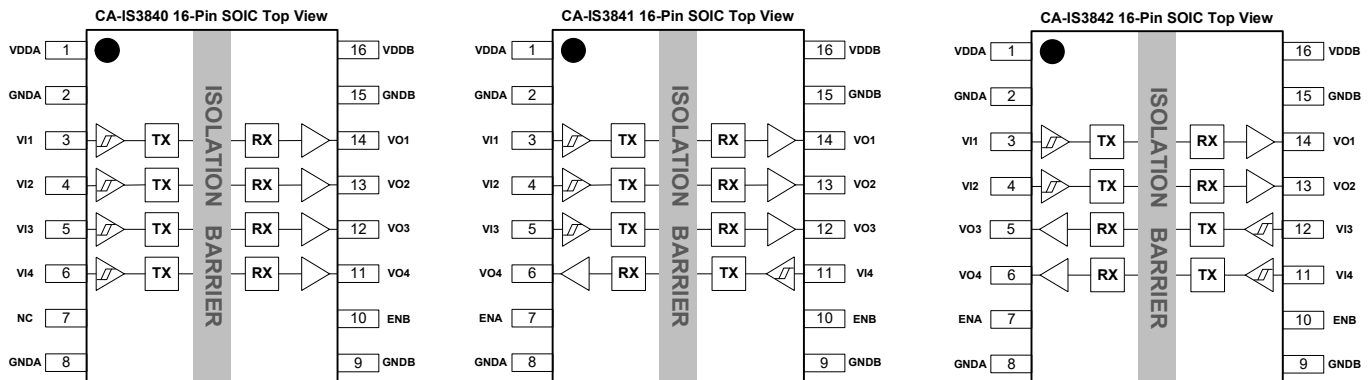

Figure 6-1 CA-IS384x Top View

Table 6-1 CA-IS384x Pin Description and Functions

| Name | SOIC16 Pin# | Type | Description |
|-----------------------------------|-------------|----------------|---|
| VDDA | 1 | Supply | Side A Power Supply |
| GNDA | 2 | Ground | Side A Ground |
| VI1 | 3 | Digital Input | Side A Digital Input |
| VI2 | 4 | Digital Input | Side A Digital Input |
| VI3/VO3 | 5 | Digital I/O | Side A Digital Input for CA-IS3840/41 or Output for CA-IS3842 |
| VI4/VO4 | 6 | Digital I/O | Side A Digital Input for CA-IS3840 or Output for CA-IS3841/42 |
| NC ¹ /ENA ² | 7 | Digital Input | Side A Active High or Floating Enable. NC for CA-IS3840 |
| GNDA | 8 | Ground | Side A Ground |
| GNDB | 9 | Ground | Side B Ground |
| ENB ² | 10 | Digital Input | Side B Active High or Floating Enable. |
| VI4/VO4 | 11 | Digital I/O | Side B Digital Input for CA-IS3841/42 or Output for CA-IS3840 |
| VI3/VO3 | 12 | Digital I/O | Side B Digital Input for CA-IS3842 or Output for CA-IS3840/41 |
| VO2 | 13 | Digital Output | Side B Digital Output |
| VO1 | 14 | Digital Output | Side B Digital Output |
| GNDB | 15 | Ground | Side B Ground |
| VDDB | 16 | Supply | Side B Power Supply |

- Note:**
- No Connect. These pins are not internally connected. They can be left floating, tied to VDD or tied to GND
 - Enable inputs ENA and ENB can be used for multiplexing, for clock sync, or other output control. ENA, ENB logic operation is summarized for each isolator product in Table 9-2. These inputs are internally pulled-up to local VDD allowing them to be connected to an external logic level (high or low) or left floating. To minimize noise coupling, do not connect circuit traces to ENA or ENB if they are left floating. If ENA, ENB are unused, it is recommended they be connected to an external logic level, especially if the CA-IS384x is operating in a noisy environment.

7 Specifications

7.1 Absolute Maximum Ratings¹

| | | MIN | MAX | UNIT |
|--------------------|-----------------------------|------|-----------------|------|
| V_{DDA}, V_{DDB} | Supply Voltage ² | -0.5 | 6.0 | V |
| V_{in} | Voltage at Ax, Bx, ENx | -0.5 | $V_{DDA}+0.5^3$ | V |
| I_O | Output Current | -20 | 20 | mA |
| T_J | Junction Temperature | | 150 | °C |
| T_{STG} | Storage Temperature | -65 | 150 | °C |

NOTE:

- Stresses beyond those listed under *Absolute Maximum Ratings* may cause permanent damage to the device. These are stress ratings only and functional operation of the device at these or any other conditions beyond those indicated under *Recommended Operating Conditions* is not implied. Exposure to absolute-maximum-rated conditions for extended periods may affect device reliability.
- All voltage values except differential I/O bus voltages are with respect to the local ground terminal (GNDA or GNDB) and are peak voltage values.
- Maximum voltage must not exceed 6 V.

7.2 ESD Ratings

| | | VALUE | UNIT |
|-----------------------------------|---|-------|------|
| V_{ESD} Electrostatic discharge | Human body model (HBM), per ANSI/ESDA/JEDEC JS-001, to the Pins on the same side ¹ | ±8000 | V |
| | Charged device model (CDM), per JEDEC specification JESD22-C101, all pins ² | ±2000 | |

NOTE:

- JEDEC document JEP155 states that 500-V HBM allows safe manufacturing with a standard ESD control process.
- JEDEC document JEP157 states that 250-V CDM allows safe manufacturing with a standard ESD control process.

7.3 Recommended Operating Conditions

| | | MIN | TYP | MAX | UNIT |
|--------------------|---|------------------|------|-------|------|
| V_{DDA}, V_{DDB} | Supply Voltage | 2.375 | | 5.5 | V |
| $V_{DD} (UVLO+)$ | VDD Undervoltage Threshold When Supply Voltage is Rising | 1.95 | 2.24 | 2.375 | V |
| $V_{DD} (UVLO-)$ | VDD Undervoltage Threshold When Supply Voltage is Falling | 1.88 | 2.10 | 2.325 | V |
| $V_{HYS} (UVLO)$ | VDD Undervoltage Threshold Hysteresis | 70 | 140 | 250 | mV |
| I_{OH} | High-level Output Current | $V_{DDO}^1 = 5V$ | | -4 | mA |
| | | $V_{DDO} = 3.3V$ | | -2 | |
| | | $V_{DDO} = 2.5V$ | | -1 | |
| I_{OL} | Low-level Output Current | $V_{DDO} = 5V$ | | 4 | mA |
| | | $V_{DDO} = 3.3V$ | | 2 | |
| | | $V_{DDO} = 2.5V$ | | 1 | |
| V_{IH} | High-level Input Voltage | 2.0 | | | V |
| V_{IL} | Low-level Input Voltage | | | 0.8 | V |
| DR | Data Rate | 0 | | 150 | Mbps |
| T_A | Ambient Temperature | -40 | 27 | 125 | °C |

NOTE:

- V_{DDO} = Output-side V_{DD}

7.4 Thermal Information

| THERMAL METRIC | | CA-IS384x | | UNIT |
|------------------|--|-----------|------|------|
| | | W | WW | |
| R _{θJA} | Junction-to-ambient thermal resistance | 83.4 | 83.4 | °C/W |

7.5 Power Rating

| PARAMETER | | TEST CONDITIONS | MIN | TYP | MAX | UNIT |
|------------------|-------------------------------------|--|-----|-----|-----|------|
| CA-IS3840 | | | | | | |
| P _D | Maximum Power Dissipation | V _{DDA} = V _{DDB} = 5.5 V, C _L = 15 pF, T _J = 150°C, Input a 75-MHz 50% duty cycle square wave | | | 334 | mW |
| P _{DA} | Maximum Power Dissipation on Side-A | | | | 36 | mW |
| P _{DB} | Maximum Power Dissipation on Side-B | | | | 298 | mW |
| CA-IS3841 | | | | | | |
| P _D | Maximum Power Dissipation | V _{DDA} = V _{DDB} = 5.5 V, C _L = 15 pF, T _J = 150°C, Input a 75-MHz 50% duty cycle square wave | | | 334 | mW |
| P _{DA} | Maximum Power Dissipation on Side-A | | | | 100 | mW |
| P _{DB} | Maximum Power Dissipation on Side-B | | | | 234 | mW |
| CA-IS3842 | | | | | | |
| P _D | Maximum Power Dissipation | V _{DDA} = V _{DDB} = 5.5 V, C _L = 15 pF, T _J = 150°C, Input a 75-MHz 50% duty cycle square wave | | | 334 | mW |
| P _{DA} | Maximum Power Dissipation on Side-A | | | | 167 | mW |
| P _{DB} | Maximum Power Dissipation on Side-B | | | | 167 | mW |

7.6 Insulation Specifications

| PARAMETR | | TEST CONDITIONS | VALUE | | UNIT |
|--|---|---|-------------------|------|------------------|
| | | | W | WW | |
| CLR | External clearance ¹ | Shortest terminal-to-terminal distance through air | >8 | >15 | mm |
| CPG | External creepage ¹ | Shortest terminal-to-terminal distance across the package surface | >8 | >15 | mm |
| DTI | Distance through the insulation | Minimum internal gap (internal clearance) | 27 | | μm |
| CTI | Comparative tracking index | DIN EN 60112 (VDE 0303-11); IEC 60112 | >600 | | V |
| | Material group | According to IEC 60664-1 | I | | |
| | Overvoltage category per IEC 60664-1 | Rated mains voltage ≤ 300 V _{RMS} | I-IV | | |
| | | Rated mains voltage ≤ 400 V _{RMS} | I-IV | | |
| | | Rated mains voltage ≤ 600 V _{RMS} | I-III | | |
| DIN V VDE V 0884-11:2017-01² | | | | | |
| V _{IORM} | Maximum repetitive peak isolation voltage | AC voltage (bipolar) | 2121 | 2828 | V _{PK} |
| V _{IOWM} | Maximum working isolation voltage | AC voltage; Time dependent dielectric breakdown (TDDB) Test | 1500 | 2000 | V _{RMS} |
| | | DC voltage | 2121 | 2828 | V _{DC} |
| V _{IOTM} | Maximum transient isolation voltage | V _{TEST} = V _{IOTM} , t = 60 s (qualification); V _{TEST} = 1.2 × V _{IOTM} , t = 1 s (100% production) | 8000 | | V _{PK} |
| V _{IOSM} | Maximum surge isolation voltage ³ | Test method per IEC 60065, 1.2/50 μs waveform, V _{TEST} = 1.6 × V _{IOSM} (qualification) | 8000 | | V _{PK} |
| q _{pd} | Apparent charge ⁴ | Method a, After Input/Output safety test subgroup 2/3, V _{ini} = V _{IOTM} , t _{ini} = 60 s; V _{pd(m)} = 1.2 × V _{IORM} , t _m = 10 s | ≤5 | | pC |
| | | Method a, After environmental tests subgroup 1, V _{ini} = V _{IOTM} , t _{ini} = 60 s; V _{pd(m)} = 1.6 × V _{IORM} , t _m = 10 s | ≤5 | | |
| | | Method b1, At routine test (100% production) and preconditioning (type test) V _{ini} = 1.2 × V _{IOTM} , t _{ini} = 1 s; V _{pd(m)} = 1.875 × V _{IORM} , t _m = 1 s | ≤5 | | |
| C _{IO} | Barrier capacitance, input to output ⁵ | V _{IO} = 0.4 × sin(2πft), f = 1 MHz | ~2 | | pF |
| R _{IO} | Isolation resistance ⁵ | V _{IO} = 500 V, T _A = 25°C | >10 ¹² | | Ω |
| | | V _{IO} = 500 V, 100°C ≤ T _A ≤ 125°C | >10 ¹¹ | | |
| | | V _{IO} = 500 V at T _S = 150°C | >10 ⁹ | | |
| | Pollution degree | | 2 | | |
| UL 1577 | | | | | |
| V _{ISO} | Maximum withstanding isolation voltage | V _{TEST} = V _{ISO} , t = 60 s (qualification), V _{TEST} = 1.2 × V _{ISO} , t = 1 s (100% production) | 5700 | | V _{RMS} |
| NOTE: | | | | | |
| 1. Creepage and clearance requirements should be applied according to the specific equipment isolation standards of an application. Care should be taken to maintain the creepage and clearance distance of a board design to ensure that the mounting pads of the isolator on the printed-circuit board do not reduce this distance. Creepage and clearance on a printed-circuit board become equal in certain cases. Techniques such as inserting grooves and/or ribs on a printed circuit board are used to help increase these specifications. | | | | | |
| 2. This coupler is suitable for safe electrical insulation only within the safety ratings. Compliance with the safety ratings shall be ensured by means of suitable protective circuits. | | | | | |
| 3. Testing is carried out in air or oil to determine the intrinsic surge immunity of the isolation barrier. | | | | | |
| 4. Apparent charge is electrical discharge caused by a partial discharge (pd). | | | | | |
| 5. All pins on each side of the barrier tied together creating a two-terminal device. | | | | | |

7.7 Safety-Related Certifications

| VDE(Pending) | UL | TUV |
|--|---|---|
| Per DIN V VDE V 0884-11:2017-01 | Recognized under UL 1577 Component Recognition Program | Recognized under EN 61010-1:2010+A1 |
| Maximum transient isolation voltage, 8000V _{pk} (SOIC16-WWB), 8000V _{pk} (SOIC16-WB) | SOIC16-WB:5700V _{RMS} ; SOIC16-WWB: 5700 V _{RMS} SOIC16-WWB: UL 7500 V _{RMS} | SOIC16-WB:5700V _{RMS} ; SOIC16-WWB: 5700 V _{RMS} |
| Certification Number: Pending | Certification Number: E511334-20200117 | Certification Number: CN23RC4J 001 |

7.8 Electrical Characteristics

7.8.1 $V_{DDA} = V_{DDB} = 5\text{ V} \pm 10\%$, $T_A = -40^\circ\text{C}$ to 125°C

| PARAMETER | | TEST CONDITIONS | MIN | TYP | MAX | UNIT |
|---------------|----------------------------------|--|-------------------|-----|--------------|-------------------------|
| V_{OH} | High-level Output Voltage | $I_{OH} = -4\text{mA}$; <i>See Figure 8-2</i> | $V_{DDO}^{1-0.4}$ | 4.8 | | V |
| V_{OL} | Low-level Output Voltage | $I_{OL} = 4\text{mA}$; <i>See Figure 8-2</i> | | 0.2 | 0.4 | V |
| $V_{IT+(IN)}$ | Positive-going Input Logic High | | 2 | | | V |
| $V_{IT-(IN)}$ | Negative-going Input Logic Low | | | | 0.8 | V |
| $V_{IT+(EN)}$ | EN Pin input Logic High | | $0.7*V_{DD}$ | | | V |
| $V_{IT-(EN)}$ | EN Pin input Logic Low | | | | $0.3*V_{DD}$ | V |
| I_{IH} | High-Level Input Leakage Current | $V_{IH} = V_{DDA}$ at Ax or Bx or ENx | | | 20 | μA |
| I_{IL} | Low-Level Input Leakage Current | $V_{IL} = 0\text{ V}$ at Ax or Bx | -20 | | | μA |
| Z_O | Output Impedance ² | | | 50 | | Ω |
| CMTI | Common-mode Transient Immunity | $V_I = V_{DDI}^1$ or 0 V, $V_{CM} = 1200\text{ V}$; <i>See Figure 8-4</i> | 100 | 150 | | $\text{kV}/\mu\text{S}$ |
| C_i | Input Capacitance ³ | $V_I = V_{DD}/2 + 0.4 \times \sin(2\pi ft)$, $f = 1\text{ MHz}$, $V_{DD} = 5\text{ V}$ | | 2 | | pF |

NOTE:

- V_{DDI} = Input-side V_{DD} , V_{DDO} = Output-side V_{DD}
- The nominal output impedance of an isolator driver channel is approximately $50\ \Omega \pm 40\%$.
- Measured from pin to Ground.

7.8.2 $V_{DDA} = V_{DDB} = 3.3\text{ V} \pm 10\%$, $T_A = -40^\circ\text{C}$ to 125°C

| PARAMETER | | TEST CONDITIONS | MIN | TYP | MAX | UNIT |
|---------------|----------------------------------|--|-------------------|-----|--------------|-------------------------|
| V_{OH} | High-level Output Voltage | $I_{OH} = -4\text{mA}$; <i>See Figure 8-2</i> | $V_{DDO}^{1-0.2}$ | 3.1 | | V |
| V_{OL} | Low-level Output Voltage | $I_{OL} = 4\text{mA}$; <i>See Figure 8-2</i> | | 0.2 | 0.4 | V |
| $V_{IT+(IN)}$ | Positive-going Input Logic High | | 2 | | | V |
| $V_{IT-(IN)}$ | Negative-going Input Logic Low | | | | 0.8 | V |
| $V_{IT+(EN)}$ | EN Pin input Logic High | | $0.7*V_{DD}$ | | | V |
| $V_{IT-(EN)}$ | EN Pin input Logic Low | | | | $0.3*V_{DD}$ | V |
| I_{IH} | High-Level Input Leakage Current | $V_{IH} = V_{DDA}$ at Ax or Bx or ENx | | | 20 | μA |
| I_{IL} | Low-Level Input Leakage Current | $V_{IL} = 0\text{ V}$ at Ax or Bx | -20 | | | μA |
| Z_O | Output Impedance ² | | | 50 | | Ω |
| CMTI | Common-mode Transient Immunity | $V_I = V_{DDI}^1$ or 0 V, $V_{CM} = 1200\text{ V}$; <i>See Figure 8-4</i> | | 100 | 150 | $\text{kV}/\mu\text{S}$ |
| C_i | Input Capacitance ³ | $V_I = V_{DD}/2 + 0.4 \times \sin(2\pi ft)$, $f = 1\text{ MHz}$, $V_{DD} = 3.3\text{ V}$ | | 2 | | pF |

NOTE:

- V_{DDI} = Input-side V_{DD} , V_{DDO} = Output-side V_{DD}
- The nominal output impedance of an isolator driver channel is approximately $50\ \Omega \pm 40\%$.
- Measured from pin to Ground.

7.8.3 $V_{DDA} = V_{DDB} = 2.5\text{ V} \pm 5\%$, $T_A = -40^\circ\text{C}$ to 125°C

| PARAMETER | | TEST CONDITIONS | MIN | TYP | MAX | UNIT |
|---------------|----------------------------------|--|-------------------|-----|--------------|-------------------------|
| V_{OH} | High-level Output Voltage | $I_{OH} = -4\text{mA}$; <i>See Figure 8-2</i> | $V_{DDO}^{1-0.4}$ | 2.3 | | V |
| V_{OL} | Low-level Output Voltage | $I_{OL} = 4\text{mA}$; <i>See Figure 8-2</i> | | 0.2 | 0.4 | V |
| $V_{IT+(IN)}$ | Positive-going Input Logic High | | 2 | | | V |
| $V_{IT-(IN)}$ | Negative-going Input Logic Low | | | | 0.8 | V |
| $V_{IT+(EN)}$ | EN Pin input Logic High | | $0.7*V_{DD}$ | | | V |
| $V_{IT-(EN)}$ | EN Pin input Logic Low | | | | $0.3*V_{DD}$ | V |
| I_{IH} | High-Level Input Leakage Current | $V_{IH} = V_{DDA}$ at Ax or Bx or ENx | | | 20 | μA |
| I_{IL} | Low-Level Input Leakage Current | $V_{IL} = 0\text{ V}$ at Ax or Bx | -20 | | | μA |
| Z_O | Output Impedance ² | | | 50 | | Ω |
| CMTI | Common-mode Transient Immunity | $V_I = V_{DDI}^1$ or 0 V, $V_{CM} = 1200\text{ V}$; <i>See Figure 8-4</i> | 100 | 150 | | $\text{kV}/\mu\text{S}$ |
| C_i | Input Capacitance ³ | $V_I = V_{DD}/2 + 0.4 \times \sin(2\pi ft)$, $f = 1\text{ MHz}$, $V_{DD} = 2.5\text{ V}$ | | 2 | | pF |

NOTE:

- V_{DDI} = Input-side V_{DD} , V_{DDO} = Output-side V_{DD}
- The nominal output impedance of an isolator driver channel is approximately $50\ \Omega \pm 40\%$.
- Measured from pin to Ground.

7.9 Supply Current Characteristics
7.9.1 $V_{DDA} = V_{DDB} = 5\text{ V} \pm 10\%$, $T_A = -40^\circ\text{C}$ to 125°C

| PARAMETER | TEST CONDITION | SUPPLY CURRENT | MIN | TYP | MAX | UNIT |
|------------------------------------|---|--------------------|-----------|-----|------|------|
| CA-IS3840 | | | | | | |
| Supply Current – Disable | ENB = 0 V; $V_{IN} = 0\text{V}$ (CA-IS3840L); $V_{IN} = V_{DDA}$ (CA-IS3840H) | I_{DDA} | | 1.3 | 2.1 | mA |
| | | I_{DDB} | | 2.5 | 3.5 | |
| | ENB = 0 V; $V_{IN} = V_{DDA}$ (CA-IS3840L); $V_{IN} = 0\text{V}$ (CA-IS3840H) | I_{DDA} | | 6.4 | 9.5 | |
| | | I_{DDB} | | 2.7 | 3.6 | |
| Supply Current – DC Signal | ENB = V_{DDB} ; $V_{IN} = 0\text{V}$ (CA-IS3840L); $V_{IN} = V_{DDA}$ (CA-IS3840H) | I_{DDA} | | 1.3 | 2.1 | |
| | | I_{DDB} | | 2.7 | 3.9 | |
| | ENB = V_{DDB} ; $V_{IN} = V_{DDA}$ (CA-IS3840L); $V_{IN} = 0\text{V}$ (CA-IS3840H) | I_{DDA} | | 6.4 | 9.5 | |
| | | I_{DDB} | | 2.7 | 4.0 | |
| Supply Current – AC Signal | ENB = V_{DDB} ; All Channels Switching with 50% Duty Cycle Square Wave Clock Input with 5V Amplitude; $C_L = 15$ pF for Each Channel | 1Mbps (500kHz) | I_{DDA} | | 3.9 | 5.8 |
| | | | I_{DDB} | | 4.4 | 6.1 |
| | | 10Mbps (5MHz) | I_{DDA} | | 3.9 | 5.8 |
| | | | I_{DDB} | | 18.7 | 24.8 |
| | | 100Mbps (50MHz) | I_{DDA} | | 4.7 | 6.8 |
| | | | I_{DDB} | | 41.0 | 54.7 |
| CA-IS3841 | | | | | | |
| Supply Current – Disable | ENA = ENB = 0 V; $V_{IN} = 0\text{V}$ (CA-IS3841L); $V_{IN} = V_{DDI}^1$ (CA-IS3841H) | I_{DDA} | | 1.5 | 2.4 | mA |
| | | I_{DDB} | | 2.3 | 3.6 | |
| | ENA = ENB = 0 V; $V_{IN} = V_{DDI}$ (CA-IS3841L); $V_{IN} = 0\text{V}$ (CA-IS3841H) | I_{DDA} | | 4.1 | 6.8 | |
| | | I_{DDB} | | 3.2 | 5.1 | |
| Supply Current – DC Signal | ENA = ENB = V_{DDI} ; $V_{IN} = 0\text{V}$ (CA-IS3841L); $V_{IN} = V_{DDI}$ (CA-IS3841H) | I_{DDA} | | 1.6 | 2.5 | |
| | | I_{DDB} | | 2.5 | 3.9 | |
| | ENA = ENB = V_{DDI} ; $V_{IN} = V_{DDI}$ (CA-IS3841L); $V_{IN} = 0\text{V}$ (CA-IS3841H) | I_{DDA} | | 4.2 | 6.9 | |
| | | I_{DDB} | | 3.5 | 5.4 | |
| Supply Current – AC Signal | ENA = ENB = V_{DDI} ; All Channels Switching with 50% Duty Cycle Square Wave Clock Input with 5V Amplitude; $C_L = 15$ pF for Each Channel | 1Mbps (500kHz) | I_{DDA} | | 3.3 | 5.2 |
| | | | I_{DDB} | | 4.1 | 6.2 |
| | | 10Mbps (5MHz) | I_{DDA} | | 6.9 | 9.9 |
| | | | I_{DDB} | | 14.0 | 19.5 |
| | | 100Mbps (50MHz) | I_{DDA} | | 14.3 | 19.8 |
| | | | I_{DDB} | | 32.5 | 44.0 |
| CA-IS3842 | | | | | | |
| Supply Current – Disable | ENA = ENB = 0 V; $V_{IN} = 0\text{V}$ (CA-IS3842L); $V_{IN} = V_{DDI}^1$ (CA-IS3842H) | I_{DDA} | | 2.2 | 3.3 | mA |
| | | I_{DDB} | | 2.2 | 3.3 | |
| | ENA = ENB = 0 V; $V_{IN} = V_{DDI}$ (CA-IS3842L); $V_{IN} = 0\text{V}$ (CA-IS3842H) | I_{DDA} | | 4.8 | 7.0 | |
| | | I_{DDB} | | 4.8 | 7.0 | |
| Supply Current – DC Signal | ENA = ENB = V_{DDI} ; $V_{IN} = 0\text{V}$ (CA-IS3842L); $V_{IN} = V_{DDI}$ (CA-IS3842H) | I_{DDA} | | 2.4 | 3.5 | |
| | | I_{DDB} | | 2.4 | 3.5 | |
| | ENA = ENB = V_{DDI} ; $V_{IN} = V_{DDI}$ (CA-IS3842L); $V_{IN} = 0\text{V}$ (CA-IS3842H) | I_{DDA} | | 4.9 | 7.1 | |
| | | I_{DDB} | | 4.9 | 7.1 | |
| Supply Current – AC Signal | ENA = ENB = V_{DDI} ; All Channels Switching with 50% Duty Cycle Square Wave Clock Input with 5V Amplitude; $C_L = 15$ pF for Each Channel | 1Mbps (500kHz) | I_{DDA} | | 4.4 | 6.3 |
| | | | I_{DDB} | | 4.4 | 6.3 |
| | | 10Mbps (5MHz) | I_{DDA} | | 11.8 | 16.0 |
| | | | I_{DDB} | | 11.8 | 16.0 |
| | | 100Mbps (50MHz) | I_{DDA} | | 24.0 | 33.0 |
| | | | I_{DDB} | | 24.0 | 33.0 |
| Note: | | | | | | |
| 1. V_{DDI} = Input-side V_{DD} | | | | | | |

7.9.2 $V_{DDA} = V_{ddb} = 3.3 V \pm 10\%$, $T_A = -40^{\circ}C$ to $125^{\circ}C$

| PARAMETER | TEST CONDITION | SUPPLY CURRENT | MIN | TYP | MAX | UNIT |
|------------------------------------|--|------------------|-----------|------|------|------|
| CA-IS3840 | | | | | | |
| Supply Current – Disable | ENB = 0 V; $V_{IN} = 0V$ (CA-IS3840L); $V_{IN} = V_{DDA}$ (CA-IS3840H) | I_{DDA} | 1.4 | 2.0 | mA | |
| | | I_{ddb} | 2.4 | 3.5 | | |
| | ENB = 0 V; $V_{IN} = V_{DDA}$ (CA-IS3840L); $V_{IN} = 0V$ (CA-IS3840H) | I_{DDA} | 6.3 | 9.5 | | |
| | | I_{ddb} | 2.4 | 3.6 | | |
| Supply Current – DC Signal | ENB = V_{ddb} ; $V_{IN} = 0V$ (CA-IS3840L); $V_{IN} = V_{DDA}$ (CA-IS3840H) | I_{DDA} | 1.4 | 2.0 | | |
| | | I_{ddb} | 2.6 | 3.7 | | |
| | ENB = V_{ddb} ; $V_{IN} = V_{DDA}$ (CA-IS3840L); $V_{IN} = 0V$ (CA-IS3840H) | I_{DDA} | 6.2 | 9.3 | | |
| | | I_{ddb} | 2.6 | 3.8 | | |
| Supply Current – AC Signal | ENB = V_{ddb} ; All Channels Switching with 50% Duty Cycle Square Wave Clock Input with 5V Amplitude; $C_L = 15$ pF for Each Channel | 1Mbps (500kHz) | I_{DDA} | 3.8 | 5.7 | |
| | | 10Mbps (5MHz) | I_{DDA} | 3.8 | 5.7 | |
| | | | I_{ddb} | 13.2 | 17.5 | |
| | | 100Mbps (50MHz) | I_{DDA} | 4.6 | 6.8 | |
| | | | I_{ddb} | 28.7 | 38.3 | |
| | | CA-IS3841 | | | | |
| Supply Current – Disable | ENA = ENB = 0 V; $V_{IN} = 0V$ (CA-IS3841L); $V_{IN} = V_{DDI}^1$ (CA-IS3841H) | I_{DDA} | 1.5 | 2.4 | mA | |
| | | I_{ddb} | 2.3 | 3.5 | | |
| | ENA = ENB = 0 V; $V_{IN} = V_{DDI}$ (CA-IS3841L); $V_{IN} = 0V$ (CA-IS3841H) | I_{DDA} | 4.0 | 6.7 | | |
| | | I_{ddb} | 3.2 | 5.1 | | |
| Supply Current – DC Signal | ENA = ENB = V_{DDI} ; $V_{IN} = 0V$ (CA-IS3841L); $V_{IN} = V_{DDI}$ (CA-IS3841H) | I_{DDA} | 1.5 | 2.4 | | |
| | | I_{ddb} | 2.4 | 3.7 | | |
| | ENA = ENB = V_{DDI} ; $V_{IN} = V_{DDI}$ (CA-IS3841L); $V_{IN} = 0V$ (CA-IS3841H) | I_{DDA} | 4.1 | 6.8 | | |
| | | I_{ddb} | 3.3 | 5.2 | | |
| Supply Current – AC Signal | ENA = ENB = V_{DDI} ; All Channels Switching with 50% Duty Cycle Square Wave Clock Input with 5V Amplitude; $C_L = 15$ pF for Each Channel | 1Mbps (500kHz) | I_{DDA} | 3.0 | 4.9 | |
| | | 10Mbps (5MHz) | I_{DDA} | 3.6 | 5.4 | |
| | | | I_{ddb} | 5.5 | 8.0 | |
| | | 100Mbps (50MHz) | I_{DDA} | 10.0 | 13.9 | |
| | | | I_{ddb} | 10.3 | 14.5 | |
| | | I_{ddb} | 21.9 | 29.7 | | |
| CA-IS3842 | | | | | | |
| Supply Current – Disable | ENA = ENB = 0 V; $V_{IN} = 0V$ (CA-IS3842L); $V_{IN} = V_{DDI}^1$ (CA-IS3842H) | I_{DDA} | 2.3 | 3.2 | mA | |
| | | I_{ddb} | 2.3 | 3.2 | | |
| | ENA = ENB = 0 V; $V_{IN} = V_{DDI}$ (CA-IS3842L); $V_{IN} = 0V$ (CA-IS3842H) | I_{DDA} | 4.9 | 6.9 | | |
| | | I_{ddb} | 4.9 | 6.9 | | |
| Supply Current – DC Signal | ENA = ENB = V_{DDI} ; $V_{IN} = 0V$ (CA-IS3842L); $V_{IN} = V_{DDI}$ (CA-IS3842H) | I_{DDA} | 2.4 | 3.3 | | |
| | | I_{ddb} | 2.4 | 3.3 | | |
| | ENA = ENB = V_{DDI} ; $V_{IN} = V_{DDI}$ (CA-IS3842L); $V_{IN} = 0V$ (CA-IS3842H) | I_{DDA} | 5.0 | 7.0 | | |
| | | I_{ddb} | 5.0 | 7.0 | | |
| Supply Current – AC Signal | ENA = ENB = V_{DDI} ; All Channels Switching with 50% Duty Cycle Square Wave Clock Input with 5V Amplitude; $C_L = 15$ pF for Each Channel | 1Mbps (500kHz) | I_{DDA} | 4.0 | 5.9 | |
| | | 10Mbps (5MHz) | I_{DDA} | 4.0 | 5.9 | |
| | | | I_{ddb} | 8.9 | 12.0 | |
| | | 100Mbps (50MHz) | I_{DDA} | 8.9 | 12.0 | |
| | | | I_{ddb} | 17.4 | 24.0 | |
| | | I_{ddb} | 17.4 | 24.0 | | |
| Note: | | | | | | |
| 1. V_{DDI} = Input-side V_{DD} | | | | | | |

7.9.3 $V_{DDA} = V_{DDB} = 2.5\text{ V} \pm 5\%$, $T_A = -40^\circ\text{C}$ to 125°C

| PARAMETER | TEST CONDITION | SUPPLY CURRENT | MIN | TYP | MAX | UNIT |
|--|---|--------------------|-----------|-----|------|------|
| CA-IS3840 | | | | | | |
| Supply Current – Disable | ENB = 0 V; $V_{IN} = 0\text{V}$ (CA-IS3840L); $V_{IN} = V_{DDA}$ (CA-IS3840H) | I_{DDA} | | 1.4 | 2.0 | mA |
| | | I_{DDB} | | 2.4 | 3.4 | |
| | ENB = 0 V; $V_{IN} = V_{DDA}$ (CA-IS3840L); $V_{IN} = 0\text{V}$ (CA-IS3840H) | I_{DDA} | | 6.3 | 9.3 | |
| | | I_{DDB} | | 2.4 | 3.5 | |
| Supply Current – DC Signal | ENB = V_{DDB} ; $V_{IN} = 0\text{V}$ (CA-IS3840L); $V_{IN} = V_{DDA}$ (CA-IS3840H) | I_{DDA} | | 1.4 | 2.0 | |
| | | I_{DDB} | | 2.5 | 3.6 | |
| | ENB = V_{DDB} ; $V_{IN} = V_{DDA}$ (CA-IS3840L); $V_{IN} = 0\text{V}$ (CA-IS3840H) | I_{DDA} | | 6.3 | 9.3 | |
| | | I_{DDB} | | 2.5 | 3.7 | |
| Supply Current – AC Signal | ENB = V_{DDB} ; All Channels Switching with 50% Duty Cycle Square Wave Clock Input with 5V Amplitude; $C_L = 15$ μF for Each Channel | 1Mbps (500kHz) | I_{DDA} | | 3.8 | 5.6 |
| | | | I_{DDB} | | 3.4 | 4.7 |
| | | 10Mbps (5MHz) | I_{DDA} | | 3.8 | 5.6 |
| | | | I_{DDB} | | 10.6 | 14.1 |
| | | 100Mbps (50MHz) | I_{DDA} | | 4.7 | 7.0 |
| | | | I_{DDB} | | 22.4 | 30.0 |
| CA-IS3841 | | | | | | |
| Supply Current – Disable | ENA = ENB = 0 V; $V_{IN} = 0\text{V}$ (CA-IS3841L); $V_{IN} = V_{DDI}^1$ (CA-IS3841H) | I_{DDA} | | 1.5 | 2.3 | mA |
| | | I_{DDB} | | 2.3 | 3.5 | |
| | ENA = ENB = 0 V; $V_{IN} = V_{DDI}$ (CA-IS3841L); $V_{IN} = 0\text{V}$ (CA-IS3841H) | I_{DDA} | | 4.0 | 6.7 | |
| | | I_{DDB} | | 3.2 | 5.0 | |
| Supply Current – DC Signal | ENA = ENB = V_{DDI} ; $V_{IN} = 0\text{V}$ (CA-IS3841L); $V_{IN} = V_{DDI}$ (CA-IS3841H) | I_{DDA} | | 1.5 | 2.4 | |
| | | I_{DDB} | | 2.4 | 3.7 | |
| | ENA = ENB = V_{DDI} ; $V_{IN} = V_{DDI}$ (CA-IS3841L); $V_{IN} = 0\text{V}$ (CA-IS3841H) | I_{DDA} | | 4.0 | 6.7 | |
| | | I_{DDB} | | 3.3 | 5.1 | |
| Supply Current – AC Signal | ENA = ENB = V_{DDI} ; All Channels Switching with 50% Duty Cycle Square Wave Clock Input with 5V Amplitude; $C_L = 15\ \mu\text{F}$ for Each Channel | 1Mbps (500kHz) | I_{DDA} | | 3.0 | 4.8 |
| | | | I_{DDB} | | 3.4 | 5.1 |
| | | 10Mbps (5MHz) | I_{DDA} | | 4.8 | 7.2 |
| | | | I_{DDB} | | 8.3 | 11.5 |
| | | 100Mbps (50MHz) | I_{DDA} | | 8.4 | 11.9 |
| | | | I_{DDB} | | 16.7 | 22.9 |
| CA-IS3842 | | | | | | |
| Supply Current – Disable | ENA = ENB = 0 V; $V_{IN} = 0\text{V}$ (CA-IS3842L); $V_{IN} = V_{DDI}^1$ (CA-IS3842H) | I_{DDA} | | 2.2 | 3.2 | mA |
| | | I_{DDB} | | 2.2 | 3.2 | |
| | ENA = ENB = 0 V; $V_{IN} = V_{DDI}$ (CA-IS3842L); $V_{IN} = 0\text{V}$ (CA-IS3842H) | I_{DDA} | | 4.6 | 6.8 | |
| | | I_{DDB} | | 4.6 | 6.8 | |
| Supply Current – DC Signal | ENA = ENB = V_{DDI} ; $V_{IN} = 0\text{V}$ (CA-IS3842L); $V_{IN} = V_{DDI}$ (CA-IS3842H) | I_{DDA} | | 2.2 | 3.2 | |
| | | I_{DDB} | | 2.2 | 3.2 | |
| | ENA = ENB = V_{DDI} ; $V_{IN} = V_{DDI}$ (CA-IS3842L); $V_{IN} = 0\text{V}$ (CA-IS3842H) | I_{DDA} | | 4.7 | 6.9 | |
| | | I_{DDB} | | 4.7 | 6.9 | |
| Supply Current – AC Signal | ENA = ENB = V_{DDI} ; All Channels Switching with 50% Duty Cycle Square Wave Clock Input with 5V Amplitude; $C_L = 15\ \mu\text{F}$ for Each Channel | 1Mbps (500kHz) | I_{DDA} | | 3.9 | 5.6 |
| | | | I_{DDB} | | 3.9 | 5.6 |
| | | 10Mbps (5MHz) | I_{DDA} | | 7.5 | 10.3 |
| | | | I_{DDB} | | 7.5 | 10.3 |
| | | 100Mbps (50MHz) | I_{DDA} | | 14.4 | 19.7 |
| | | | I_{DDB} | | 14.4 | 19.7 |
| Note: | | | | | | |
| 1. $V_{DDI} = \text{Input-side } V_{DD}$ | | | | | | |

7.10 Timing Characteristics

7.10.1 $V_{DDA} = V_{DDB} = 5 V \pm 10\%$, $T_A = -40^{\circ}C$ to $125^{\circ}C$

| PARAMETER | | TEST CONDITIONS | MIN | TYP | MAX | UNIT |
|-------------------------------------|---|-------------------------|-----|-----|-----|------|
| DR | Data Rate | | 0 | | 150 | Mbps |
| PW _{min} | Minimum Pulse Width | | | | 5 | ns |
| t _{PLH} , t _{PHL} | Propagation Delay Time | See Figure 8-1 | | 12 | 15 | ns |
| PWD | Pulse Width Distortion t _{PLH} - t _{PHL} | | 0.2 | 4.5 | ns | |
| t _{sk(o)} | Channel-to-channel Output Skew Time ¹ | Same-direction channels | | 0.4 | 2.5 | ns |
| t _{sk(pp)} | Part-to-part Skew Time ² | | | 2.0 | 4.5 | ns |
| t _r | Output Signal Rise Time | See Figure 8-1 | | 2.5 | 4.0 | ns |
| t _f | Output Signal Fall Time | See Figure 8-1 | | 2.5 | 4.0 | ns |
| t _{PHZ} | Disable Propagation Delay, High to High Impedance Output | See Figure 8-2 | | 12 | 20 | ns |
| t _{PLZ} | Disable Propagation Delay, Low to High Impedance Output | | 12 | 20 | ns | |
| t _{PZH} | Enable Propagation Delay, High Impedance to High Output | | 15 | 25 | ns | |
| t _{PZL} | Enable Propagation Delay, High Impedance to Low Output | | 15 | 25 | ns | |
| t _{DO} | Default Output Delay Time from Input Power Loss | See Figure 8-3 | | 8 | 12 | μs |
| t _{SU} | Start-up Time | | | 15 | 40 | μs |

NOTE:

- t_{sk(o)} is the skew between outputs of a single device with all driving inputs connected together and the outputs switching in the same direction while driving identical loads.
- t_{sk(pp)} is the magnitude of the difference in propagation delay times between any terminals of different devices switching in the same direction while operating at identical supply voltages, temperature, input signals and loads.

7.10.2 $V_{DDA} = V_{DDB} = 3.3 V \pm 10\%$, $T_A = -40^{\circ}C$ to $125^{\circ}C$

| PARAMETER | | TEST CONDITIONS | MIN | TYP | MAX | UNIT |
|-------------------------------------|---|-------------------------|-----|-----|-----|------|
| DR | Data Rate | | 0 | | 150 | Mbps |
| PW _{min} | Minimum Pulse Width | | | | 5 | ns |
| t _{PLH} , t _{PHL} | Propagation Delay Time | See Figure 8-1 | | 12 | 17 | ns |
| PWD | Pulse Width Distortion t _{PLH} - t _{PHL} | | 0.2 | 4.5 | ns | |
| t _{sk(o)} | Channel-to-channel Output Skew Time ¹ | Same-direction channels | | 0.4 | 2.5 | ns |
| t _{sk(pp)} | Part-to-part Skew Time ² | | | 2.0 | 4.5 | ns |
| t _r | Output Signal Rise Time | See Figure 8-1 | | 2.5 | 4.0 | ns |
| t _f | Output Signal Fall Time | See Figure 8-1 | | 2.5 | 4.0 | ns |
| t _{PHZ} | Disable Propagation Delay, High to High Impedance Output | See Figure 8-2 | | 12 | 20 | ns |
| t _{PLZ} | Disable Propagation Delay, Low to High Impedance Output | | 12 | 20 | ns | |
| t _{PZH} | Enable Propagation Delay, High Impedance to High Output | | 15 | 25 | ns | |
| t _{PZL} | Enable Propagation Delay, High Impedance to Low Output | | 15 | 25 | ns | |
| t _{DO} | Default Output Delay Time from Input Power Loss | See Figure 8-3 | | 8 | 12 | μs |
| t _{SU} | Start-up Time | | | 15 | 40 | μs |

NOTE:

- t_{sk(o)} is the skew between outputs of a single device with all driving inputs connected together and the outputs switching in the same direction while driving identical loads.
- t_{sk(pp)} is the magnitude of the difference in propagation delay times between any terminals of different devices switching in the same direction while operating at identical supply voltages, temperature, input signals and loads.

7.10.3 $V_{DDA} = V_{DDB} = 2.5 V \pm 5\%$, $T_A = -40^{\circ}C$ to $125^{\circ}C$

| PARAMETER | | TEST CONDITIONS | MIN | TYP | MAX | UNIT |
|-------------------------------------|---|-------------------------|-----|-----|-----|------|
| DR | Data Rate | | 0 | | 150 | Mbps |
| PW _{min} | Minimum Pulse Width | | | | 5 | ns |
| t _{PLH} , t _{PHL} | Propagation Delay Time | <i>See Figure 8-1</i> | | 12 | 20 | ns |
| PWD | Pulse Width Distortion t _{PLH} - t _{PHL} | | | 0.2 | 4.5 | ns |
| t _{sk(o)} | Channel-to-channel Output Skew Time ¹ | Same-direction channels | | 0.4 | 2.5 | ns |
| t _{sk(pp)} | Part-to-part Skew Time ² | | | 2 | 5 | ns |
| t _r | Output Signal Rise Time | <i>See Figure 8-1</i> | | 2.5 | 4.0 | ns |
| t _f | Output Signal Fall Time | <i>See Figure 8-1</i> | | 2.5 | 4.0 | ns |
| t _{PHZ} | Disable Propagation Delay, High to High Impedance Output | <i>See Figure 8-2</i> | | 12 | 20 | ns |
| t _{PLZ} | Disable Propagation Delay, Low to High Impedance Output | | | 12 | 20 | ns |
| t _{PZH} | Enable Propagation Delay, High Impedance to High Output | | | 15 | 25 | ns |
| t _{PZL} | Enable Propagation Delay, High Impedance to Low Output | | | 15 | 25 | ns |
| t _{DO} | Default Output Delay Time from Input Power Loss | <i>See Figure 8-3</i> | | 8 | 12 | μs |
| t _{SU} | Start-up Time | | | 15 | 40 | μs |

NOTE:

1. t_{sk(o)} is the skew between outputs of a single device with all driving inputs connected together and the outputs switching in the same direction while driving identical loads.
2. t_{sk(pp)} is the magnitude of the difference in propagation delay times between any terminals of different devices switching in the same direction while operating at identical supply voltages, temperature, input signals and loads.

8 Parameter Measurement Information

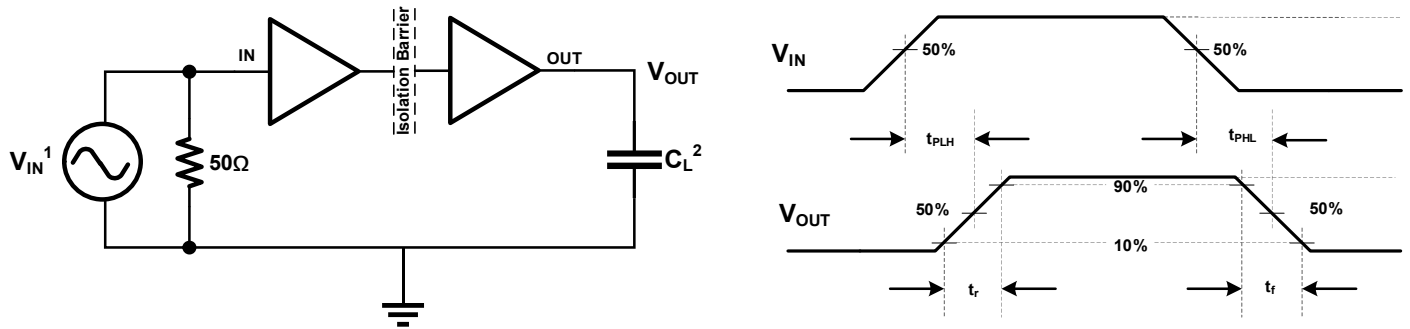

NOTE:

1. A square wave generator generate the V_{IN} input signal with the following constraints: waveform frequency $\leq 100\text{kHz}$, 50% duty cycle, $t_r \leq 3\text{ns}$, $t_f \leq 3\text{ns}$. Since the waveform generator has an output impedance of $Z_{out} = 50\Omega$, the 50Ω resistor in the figure is used for matching. There is no need in the actual application.
2. C_L is the load capacitance about 15pF together with the instrumentation capacitance. Since the load capacitance influence the output rising time, it's a key factor in the timing characteristic measurement.

Figure 8-1 Timing Characteristics Test Circuit and Voltage Waveforms

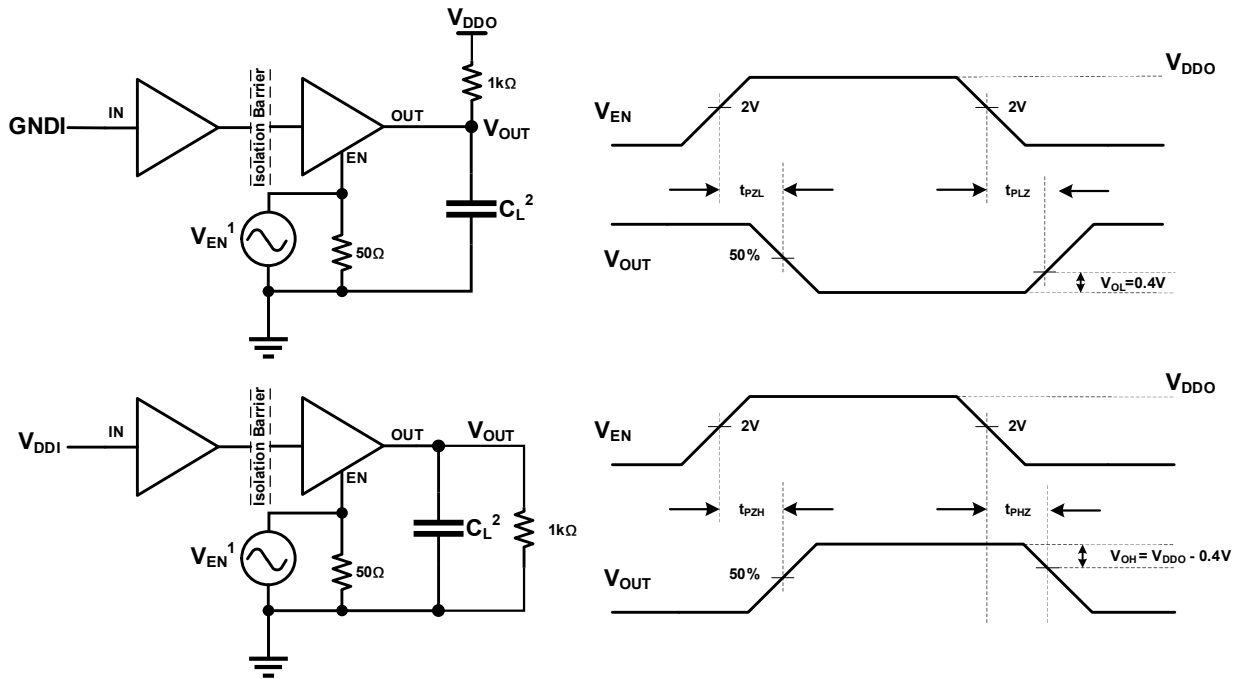

NOTE:

1. A square wave generator generate the V_{EN} input signal with the following constraints: waveform frequency $\leq 100\text{kHz}$, 50% duty cycle, $t_r \leq 3\text{ns}$, $t_f \leq 3\text{ns}$. Since the waveform generator has an output impedance of $Z_{out} = 50\Omega$, the 50Ω resistor in the figure is used for matching. There is no need in the actual application.
2. C_L is the load capacitance about 15pF together with the instrumentation capacitance. Since the load capacitance influence the output rising time, it's a key factor in the timing characteristic measurement.

Figure 8-2 Enable/Disable Propagation Delay Time Test Circuit and Waveform

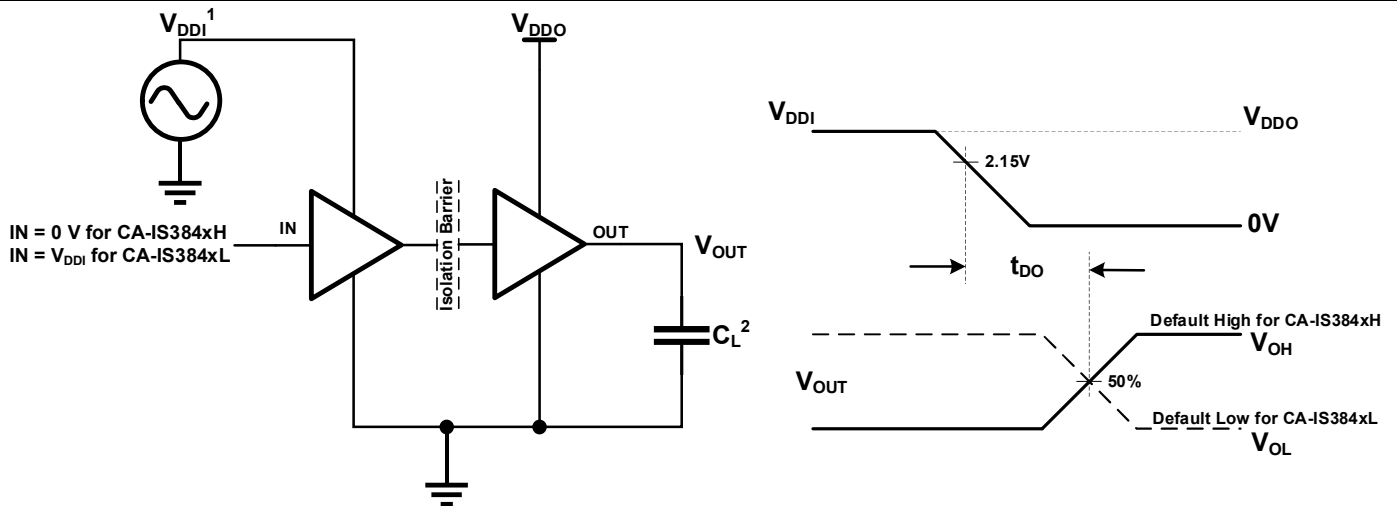

NOTE:

1. Power Supply Ramp Rate = 10 mV/ns. V_{DDI} should ramp over 2.375V but no higher than 5.5V.
2. C_L is the load capacitance about 15pF together with the instrumentation capacitance. Since the load capacitance influence the output rising time, it's a key factor in the timing characteristic measurement.

Figure 8-3 Default Output Delay Time Test Circuit and Voltage Waveforms

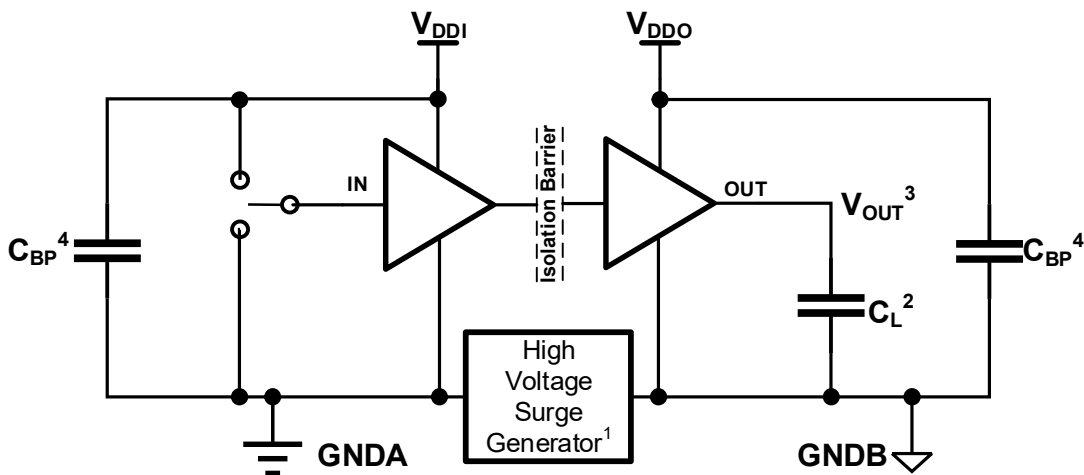

NOTE:

1. The High Voltage Surge Generator generates repetitive high voltage surges with > 1kV amplitude and <10ns rise time and fall time to reach common-mode transient noise with > 150kV/ μ s slew rate.
2. C_L is the load capacitance about 15pF together with the instrumentation capacitance.
3. Pass-fail criteria: The output must remain stable whenever the high voltage surges come.
4. C_{BP} is the 0.1 ~ 1 μ F bypass capacitance.

Figure 8-4 Common-Mode Transient Immunity Test Circuit

9 Detailed Description

9.1 Theory of Operation

The CA-IS38xx family of devices use a simple ON-OFF keying (OOK) modulation scheme to transmit signal across the SiO₂ isolation capacitors that provide a robust insulation between two different voltage domain and act as a high frequency signal path between the input and the output. The transmitter (TX) modulates the input signal onto the carrier frequency, that is, TX delivers high frequency signal across the isolation barrier in one input state and delivers no signal across the barrier in the other input state. Then the receiver rebuilds the input signal according to the detected in-band energy. This simple architecture offers a robust isolated data path and requires no special considerations or initialization at start-up. The capacitor-based signal path is fully differential to maximize noise immunity, which is also known as common-mode transient immunity. Advanced circuitry techniques are applied for better EMI introduced by the carrier signal and IO switching. The capacitively-coupled architecture provides much higher electromagnetic immunity compared to the inductively-coupled one. And OOK modulation scheme eliminates the missing-pulse error that occurs in the pulse modulation method. A simplified functional block diagram and conceptual operation waveforms of a single channel is shown in Figure 9-1 and Figure 9-2.

9.2 Functional Block Diagram

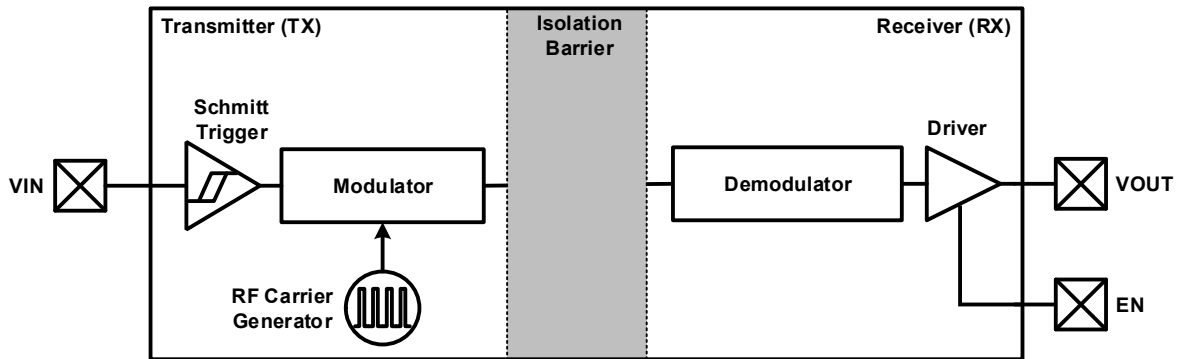

Figure 9-1 Functional Block Diagram of a Single Channel

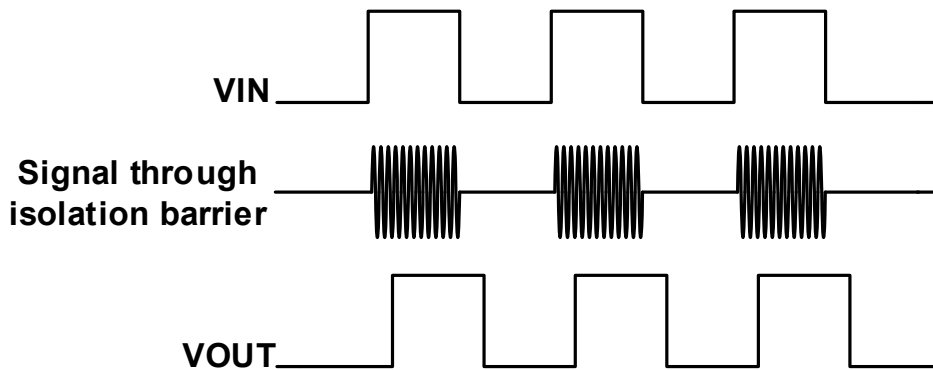

Figure 9-2 Conceptual Operation Waveforms of a Single Channel

9.3 Device Operation Modes

Table 9-1 provides the operation modes for the CA-IS384x devices.

Table 9-1 Operation Mode Table¹

| V _{DDI} | V _{DDO} | INPUT(Ax/Bx) ² | OUTPUT ENABLE(ENx) ^{3,4} | OUTPUT (Ax/Bx) | OPERATION |
|------------------|------------------|---------------------------|-----------------------------------|----------------|---|
| PU | PU | H | H or Open | H | Normal operation mode: A channel's output follows the input state |
| | | L | H or Open | L | |
| | | Open | H or Open | Default | Default output fail-safe mode: If a channel's input is left open, its output goes to the default value (Low for CA-IS384xL and High for CA-IS384xH). |
| X | PU | X | L | Z | High impedance mode: If Enable pin is tied to low, the output will be in high-Z mode |
| PD | PU | X | H or Open | Default | Default output fail-safe mode: If the input side VDD is unpowered, the outputs go in to the default output fail-safe mode (Low for CA-IS384xL and High for CA-IS384xH) |
| X | PD | X | X | Undetermined | If the output side VDD is unpowered, the outputs' states are undetermined. ⁵ |

NOTE:

- V_{DDI} = Input-side V_{DD}; V_{DDO} = Output-side V_{DD}; PU = Powered up (VCC ≥ 2.375 V); PD = Powered down (VCC ≤ 2.25 V); X = Irrelevant; H = High level; L = Low level; Z = High Impedance.
- A strongly driven input signal can weakly power the floating V_{DD} through an internal protection diode and cause undetermined output.
- It is recommended that the enable inputs be connected to an external logic high or low level when the CA-IS384x is operating in noisy environments.
- No Connect (NC) replaces ENA on CA-IS3840. No Connects are not internally connected and can be left floating, tied to VDD, or tied to GND.
- The outputs are in undetermined state when 2.25V < V_{DDI}, V_{DDO} < 2.375 V.

Table 9-2 provides the Enable input truth table for the CA-IS384x devices.

Table 9-2 Enable Input Truth Table

| PART NUMBER | ENA ^{1,2} | ENB ^{1,2} | OPERATION |
|-------------|--------------------|--------------------|--|
| CA-IS3840 | — | H | Outputs VO1, VO2, VO3, VO4 are enabled and follow the input state. |
| | — | L | Outputs VO1, VO2, VO3, VO4 are disabled and in high impedance state. |
| CA-IS3841 | H | X | Output VO4 enabled and follows the input state. |
| | L | X | Output VO4 disabled and in high impedance state. |
| | X | H | Outputs VO1, VO2, VO3 are enabled and follow the input state. |
| | X | L | Outputs VO1, VO2, VO3 are disabled and in high impedance state. |
| CA-IS3842 | H | X | Outputs VO3 and VO4 are enabled and follow the input state. |
| | L | X | Outputs VO3 and VO4 are disabled and in high impedance state. |
| | X | H | Outputs VO1 and VO2 are enabled and follow the input state. |
| | X | L | Outputs VO1 and VO2 are disabled and in high impedance state. |

NOTE:

- Enable inputs ENA and ENB can be used for multiplexing, for clock sync, or other output control. ENA, ENB logic operation is summarized for each isolator product in Table 9-2. These inputs are internally pulled-up to local VDD allowing them to be connected to an external logic level (high or low) or left floating. To minimize noise coupling, do not connect circuit traces to ENA or ENB if they are left floating. If ENA, ENB are unused, it is recommended they be connected to an external logic level, especially if the CA-IS384x is operating in a noisy environment.
- X = Irrelevant; H = High level; L = Low level.

10 Application and Implementation

Unlike optocouplers, which need external components to improve performance, provide bias, or limit current, the CA-IS384x family device CMOS digital isolator needs only two external VDD bypass capacitors (0.1μF to 1 μF) to operate. Its TTL level compatible input terminals draw only micro amps of leakage current, allowing them to be driven without external buffering circuits. The output terminals have a characteristic impedance of 50 Ω (rail-to-rail swing) and are available in both forward and reverse channel configurations. Figure 10-1 shows the typical application of CA-IS3842 device. And the circuit of Figure 10-2 is typical for most applications of CA-IS38xx series products and is as easy to use as a standard logic gate.

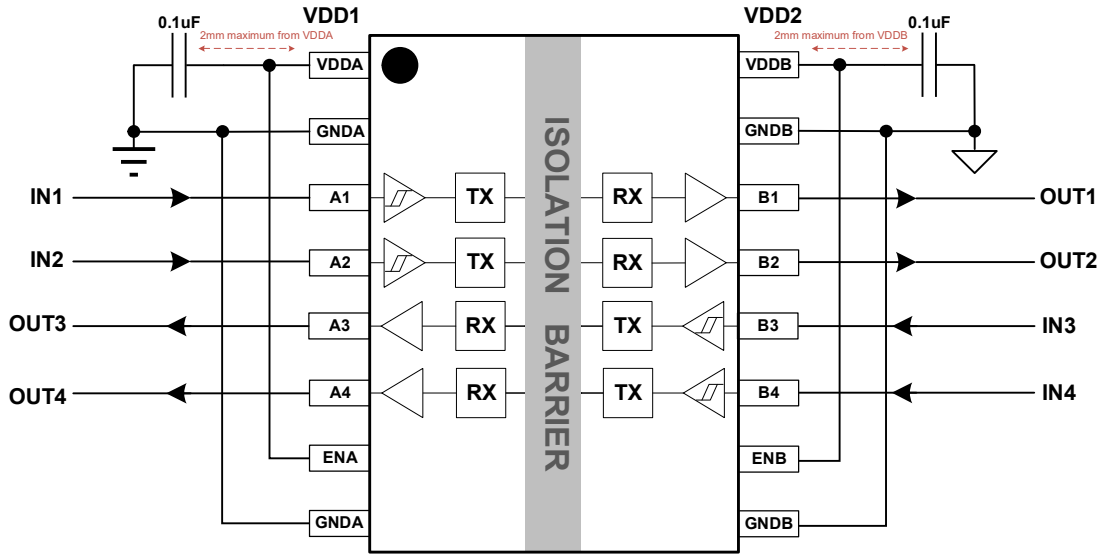

Figure 10-1 Typical Application Circuit of CA-IS3842

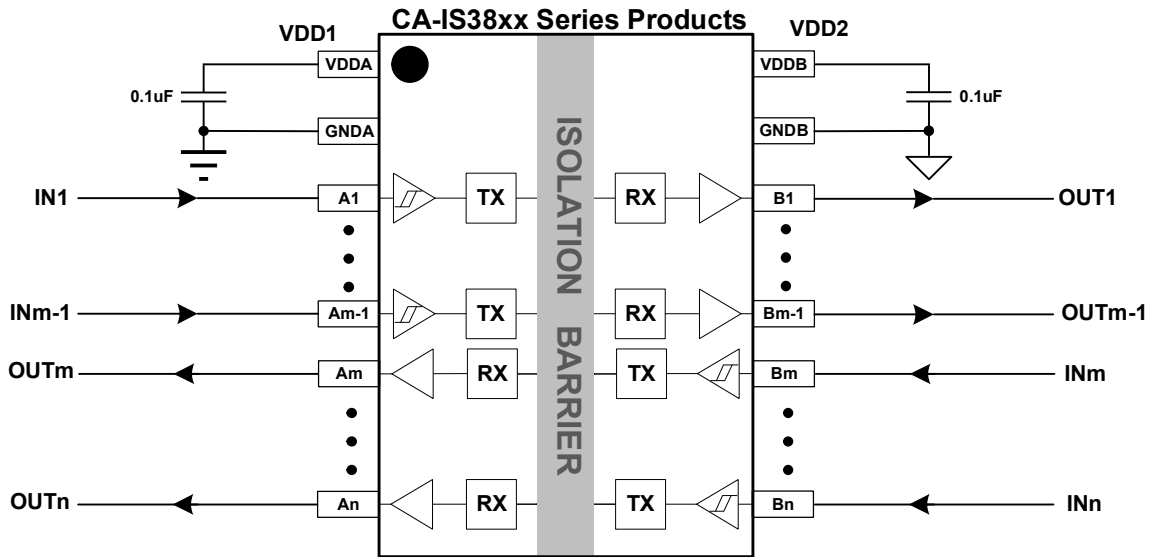
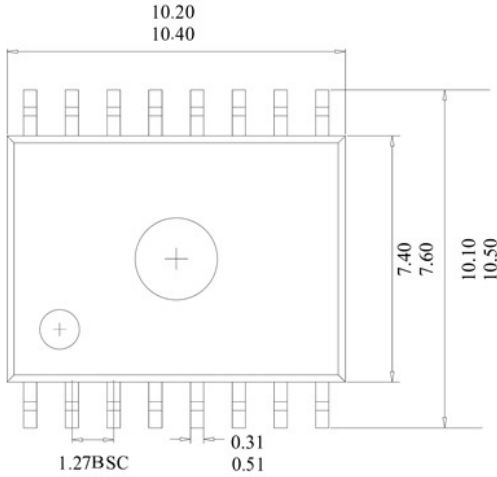

Figure 10-2 CA-IS38xx Series Digital Isolator Application Schematic

11 Package Information

11.1 16-Pin Wide Body SOIC Package(10.30 mm × 7.50 mm)

The figure below illustrates the package details and the recommended land pattern details for the CA-IS384x digital isolator in a 16-pin wide-body SOIC package. The values for the dimensions are shown in millimeters.



TOP VIEW

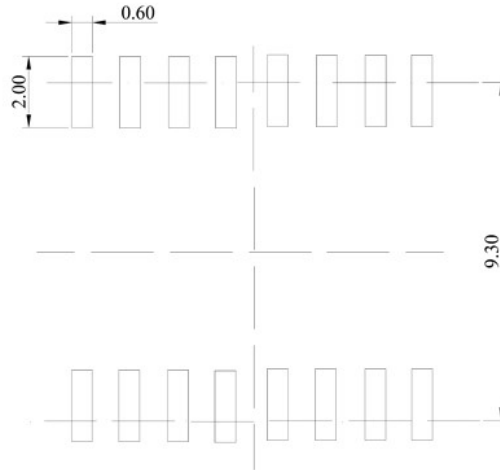

RECOMMENDED LAND PATTERN

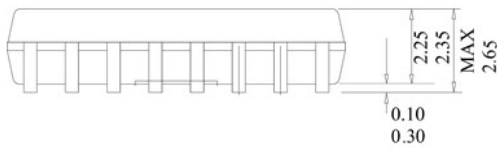

FRONT VIEW



SIDE VIEW

11.2 16-Pin Extra Wide Body SOIC Package (10.30 mm × 14.00 mm)

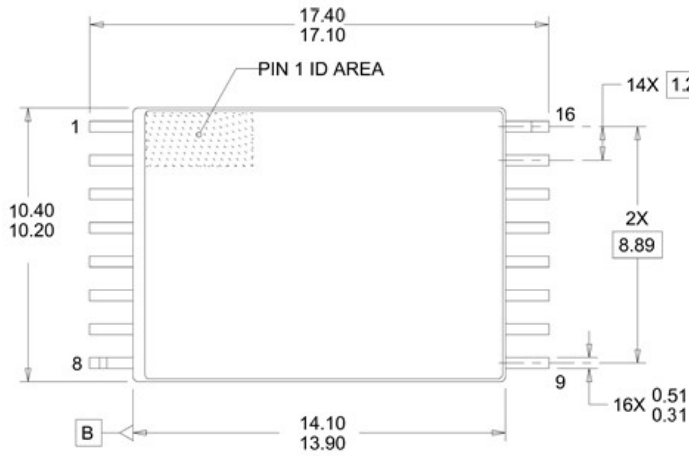

TOP VIEW

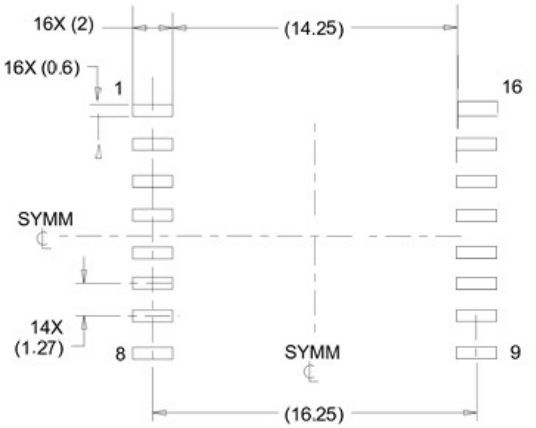

STANDARD
RECOMMENDED LAND PATTERN



FRONT VIEW

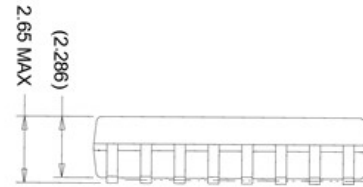

SIDE VIEW

12 Soldering Information

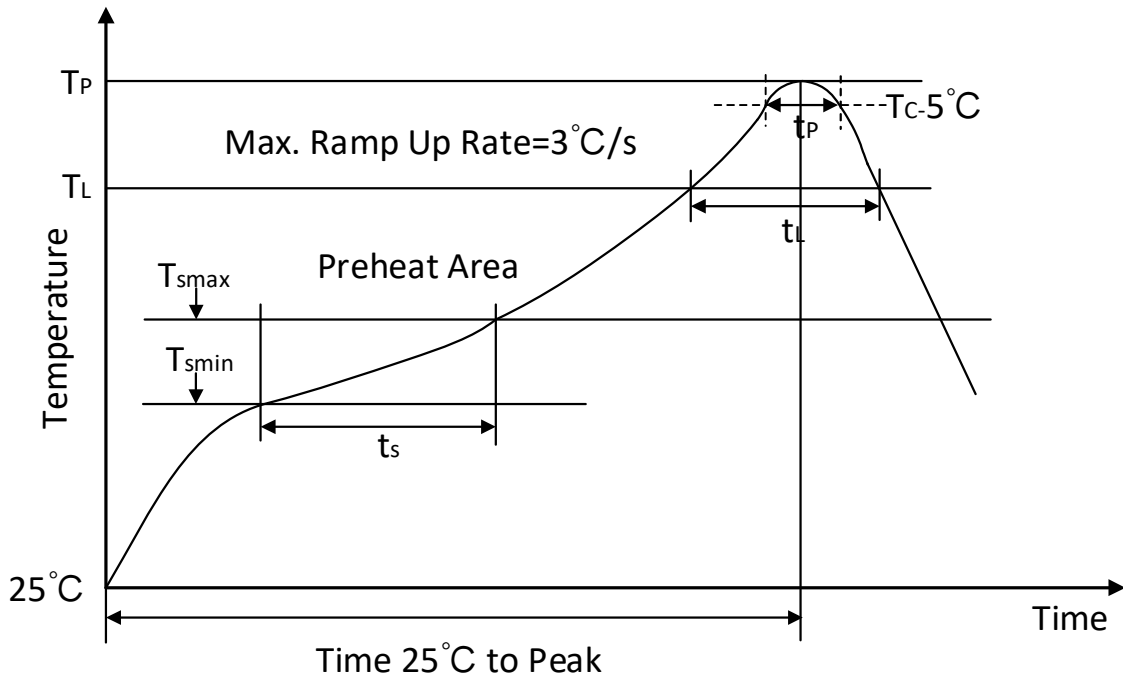

Figure12- 1 Soldering Temperature (reflow) Profile

Table12- 1 Soldering Temperature Parameter

| Profile Feature | Pb-Free Assembly |
|---|-------------------|
| Average ramp-up rate(217 °C to Peak) | 3°C /second max |
| Time of Preheat temp(from 150 °C to 200 °C) | 60-120 second |
| Time to be maintained above 217 °C | 60-150 second |
| Peak temperature | 260 °C |
| Time within 5°C of actual peak temp | 30 second |
| Ramp-down rate | 6 °C /second max. |
| Time from 25°C to peak temp | 8 minutes max |

13 Tape And Reel Information

REEL DIMENSIONS

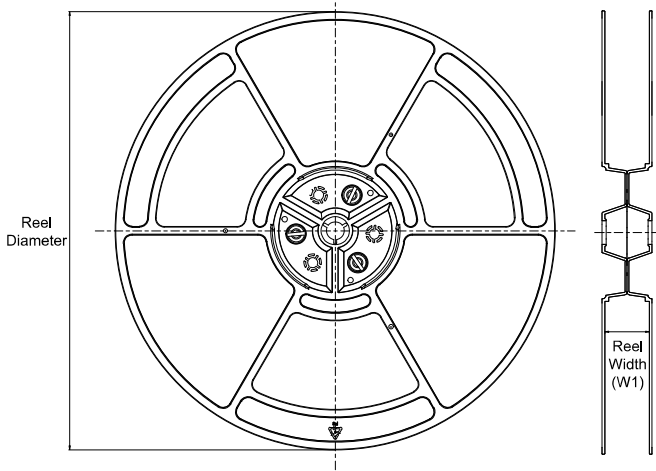

TAPE DIMENSIONS

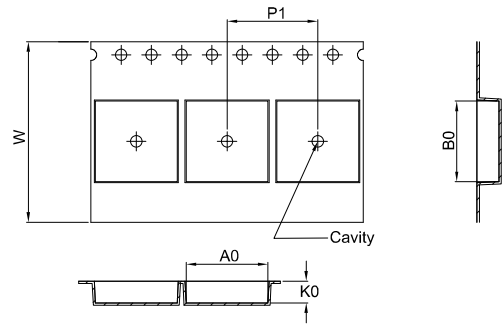

| | |
|----|---|
| A0 | Dimension designed to accommodate the component width |
| B0 | Dimension designed to accommodate the component length |
| K0 | Dimension designed to accommodate the component thickness |
| W | Overall width of the carrier tape |
| P1 | Pitch between successive cavity centers |

QUADRANT ASSIGNMENTS FOR PIN 1 ORIENTATION IN TAPE

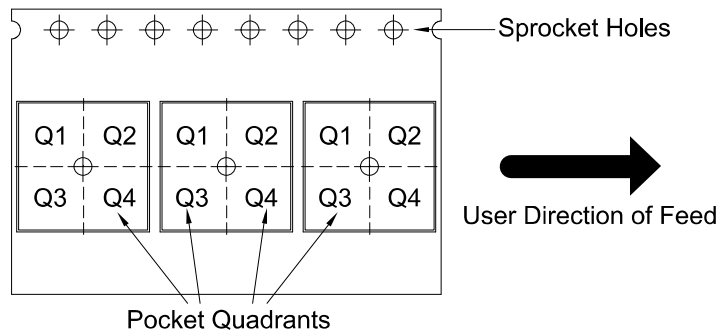

*All dimensions are nominal

| Device | Package Type | Package Drawing | Pins | SPQ | Reel Diameter (mm) | Reel Width W1 (mm) | A0 (mm) | B0 (mm) | K0 (mm) | P1 (mm) | W (mm) | Pin1 Quadrant |
|--------------|--------------|-----------------|------|------|--------------------|--------------------|---------|---------|---------|---------|--------|---------------|
| CA-IS3840LW | SOIC | W | 16 | 1000 | 330 | 16.4 | 10.9 | 10.7 | 3.2 | 12.0 | 16.0 | Q1 |
| CA-IS3840HW | SOIC | W | 16 | 1000 | 330 | 16.4 | 10.9 | 10.7 | 3.2 | 12.0 | 16.0 | Q1 |
| CA-IS3841LW | SOIC | W | 16 | 1000 | 330 | 16.4 | 10.9 | 10.7 | 3.2 | 12.0 | 16.0 | Q1 |
| CA-IS3841HW | SOIC | W | 16 | 1000 | 330 | 16.4 | 10.9 | 10.7 | 3.2 | 12.0 | 16.0 | Q1 |
| CA-IS3842LW | SOIC | W | 16 | 1000 | 330 | 16.4 | 10.9 | 10.7 | 3.2 | 12.0 | 16.0 | Q1 |
| CA-IS3842HW | SOIC | W | 16 | 1000 | 330 | 16.4 | 10.9 | 10.7 | 3.2 | 12.0 | 16.0 | Q1 |
| CA-IS3840LWW | SOIC | WW | 16 | 1000 | 330 | 24.4 | 10.7 | 17.7 | 3.1 | 16.0 | 24.0 | Q1 |
| CA-IS3840HWW | SOIC | WW | 16 | 1000 | 330 | 24.4 | 10.7 | 17.7 | 3.1 | 16.0 | 24.0 | Q1 |
| CA-IS3841LWW | SOIC | WW | 16 | 1000 | 330 | 24.4 | 10.7 | 17.7 | 3.1 | 16.0 | 24.0 | Q1 |
| CA-IS3841HWW | SOIC | WW | 16 | 1000 | 330 | 24.4 | 10.7 | 17.7 | 3.1 | 16.0 | 24.0 | Q1 |
| CA-IS3842LWW | SOIC | WW | 16 | 1000 | 330 | 24.4 | 10.7 | 17.7 | 3.1 | 16.0 | 24.0 | Q1 |
| CA-IS3842HWW | SOIC | WW | 16 | 1000 | 330 | 24.4 | 10.7 | 17.7 | 3.1 | 16.0 | 24.0 | Q1 |

14 **Important Notice**

The above information is for reference only and is used to assist Chipanalog customers in design and development. Chipanalog reserves the right to change the above information due to technological innovation without prior notice.

Chipanalog products are all factory tested. The customers shall be responsible for self-assessment and determine whether it is applicable for their specific application. Chipanalog's authorization to use the resources is limited to the development of related applications that the Chipanalog products involved in. In addition, the resources shall not be copied or displayed. And Chipanalog shall not be liable for any claim, cost, and loss arising from the use of the resources.

Trademark Information

Chipanalog Inc. ®, Chipanalog® are trademarks or registered trademarks of Chipanalog.



<http://www.chipanalog.com>