

Transmittal, reproduction, dissemination and/or editing of this document as well as utilization of its contents and communication thereof to others without express authorization are prohibited.  
未经允许禁止传输、复制、编辑该文档，以及利用其内容进行交流

REVISION RECORD

REV	ECN	DESCRIPTION	DRFT	DATE

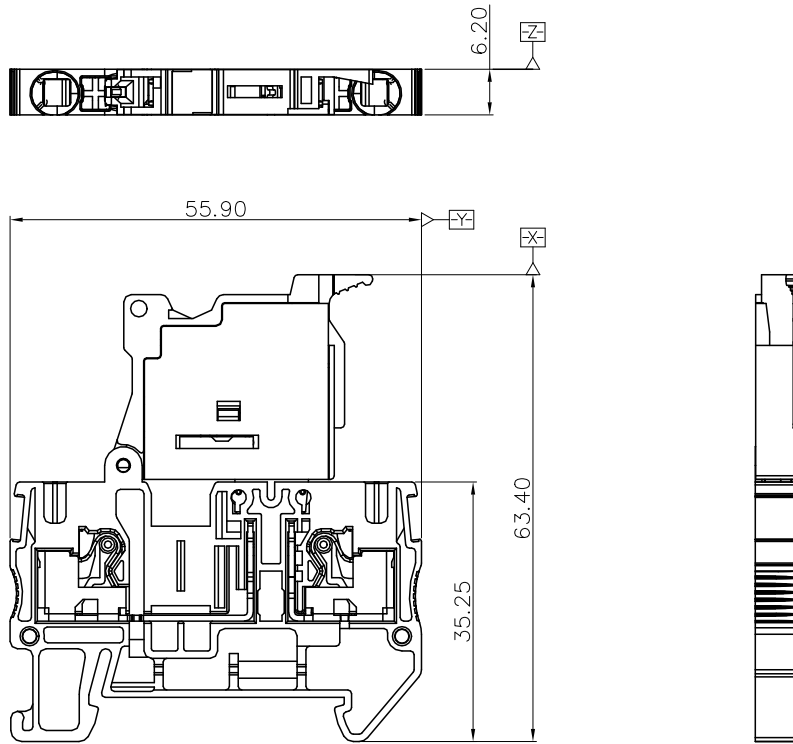

Connection method:

1. For Solid wire, peel wire in right length, push down the wire.
2. For flexible wire, peeling wire in right length, pushdown the key & fix the wire, or wire furrled and fix then.

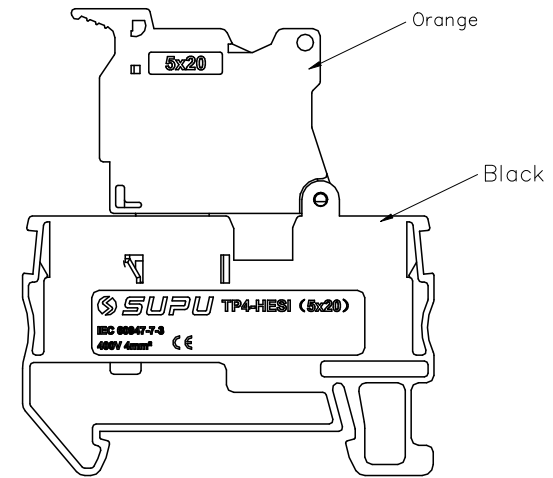

NOTES:

UL/CUL Standard

1. Conductor cross section : 24~10AWG
2. Rated Voltage/Current :

Use group	B	C	D
Rated voltage(V)	300	300	
Rated current(A)	16	16	

Material:

Insulator	PA66	UL94 V-0
Conductor	Copper alloy	Sn Plated
Spring	Stainless steel	
Button	PA66	UL94 V-0

IEC Standard

1. Conductor cross section :

Wire range(Solid/Stranded)	0.2-4mm <sup>2</sup>
Solid	0.2-6mm <sup>2</sup>
Stranded	0.2-4mm <sup>2</sup>
Stranded with ferrules without plastic sleeve	0.2-4mm <sup>2</sup>
Stranded with ferrules with plastic sleeve	0.2-4mm <sup>2</sup>

2. Rated Voltage/Current :

Surge voltage category	III
Pollution degree	3
Rated surge voltage(KV)	6
Rated voltage(V)	500
Rated current(A)	20

General information:

1. Dimension shall be interpreted per ASME Y14.5-2009
2. Stripping length : 10~12mm
3. Operating temperature: -40°C~+105°C
4. RoHS Compliance
5. Undimensioned Tolerances:

Pitch Range In mm	Nominal Dimension Range In mm							—	∩	∇
	Over 6	Over 10	Over 10	Over 24	Over 30	Over 60	Over 100	Over 150	0.1/10	
TO	TO	TO	TO	TO	TO	TO	TO	TO	<	
±0.15	±0.20	±0.30	±0.30	±0.50	±0.70	±1.00	±1.30	±2'		

HOW TO ORDER:

TP4-HEDI-XXXX

Series No. Customer request

借通用件登记  
Common Part

原图号  
Old Draw. No.

底图总号  
Assembly No.

订货号 Order No.	TP4-HEDI		名称 Name	TP系列-正面接线-02P-4mm <sup>2</sup> 悬臂式分断端子 黑色/橙色	未注公差 Tolerance	表面处理 Surface	
项目 Item	签字 Signature	日期 Date	图号 Drawing No.	PRM003502	Tolerances Table	VDI21	
设计 Design	QLD	12/13/22'	材料 Material	Notes	版本号 Revision Number	重量 Weight	比例 Scale
审核 Check	DF	12/13/22'	物料号 Item No.	411520131	T0-1	/	1:1
工艺 Process	-	-	第1页/共1页 1 of 1		mm		
标准化 Unify	-	-	<b>SUPU 宁波速普电子有限公司</b>				
批准 Approve	LWL	12/13/22'	<b>NINGBO SUPU ELECTRONICS CO.,LTD.</b>				

1

2

3

4

5

6

7

8