

Non-isolated Off-line PWM converters

General Description

The PN8016 consists of an integrated Pulse Width Modulator (PWM) controller and power MOSFET, specifically designed for small power non-isolated switching power supply. Variable output voltage could be adjusted by FB resistors. PN8016 has internal high voltage start-up and self-supply circuit, and complete intelligent protections including Over Load Protection (OLP), Under Voltage Lockout (UVLO) and Over Temperature Protection (OTP). Excellent EMI performance could be achieved with Pulse Frequency Modulation.

Features

- Internal 800V avalanche-rugged smart power VDMOSFET
- Internal HV Start-up Circuit
- Supporting Buck, Buck-Boost and Flyback topologies
- Variable Output Voltage 3.3V~18V adjusted by FB resistors
- Semi enclosed steady output current 300mA @230VAC,5V
- Frequency modulation for low EMI
- Excellent constant voltage regulation and High efficiency
- Excellent Protection Coverage:
 - ◇ Over Load Protection (OLP)
 - ◇ Over Temperature Protection (OTP)
 - ◇ Under Voltage Lockout (UVLO)

Applications

- non-isolated assistant power supply
- Household appliance
- Smart Home
- LED

Package/Order Information

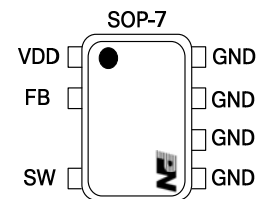

Order Code	Package
PN8016SSC-R1B	SOP-7

Typical Circuit

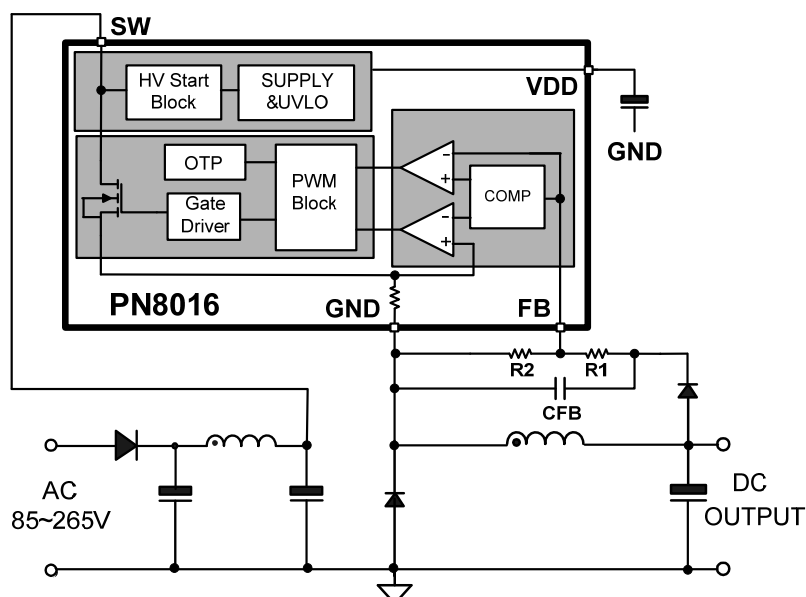

Pin Definitions

Pin Name	Pin Number	Pin Function Description
VDD	1	VDD supply
FB	2	Output voltage feedback
SW	3	Drain of the internal MOSFET
GND	4、5、6、7	Ground

Typical Power

Part number	Input Voltage	Steady output power ⁽¹⁾	Peak Power ⁽²⁾
PN8016	85-265 V _{AC}	1.5W(5V300mA)	1.5W(5V400mA)

Note:

1. Maximum output power in a semi enclosed design measured at 75°C ambient temperature, Duration:2 hours
2. Peak power in a semi enclosed design measured at 75°C ambient temperature, Duration:1 min

Block Diagram

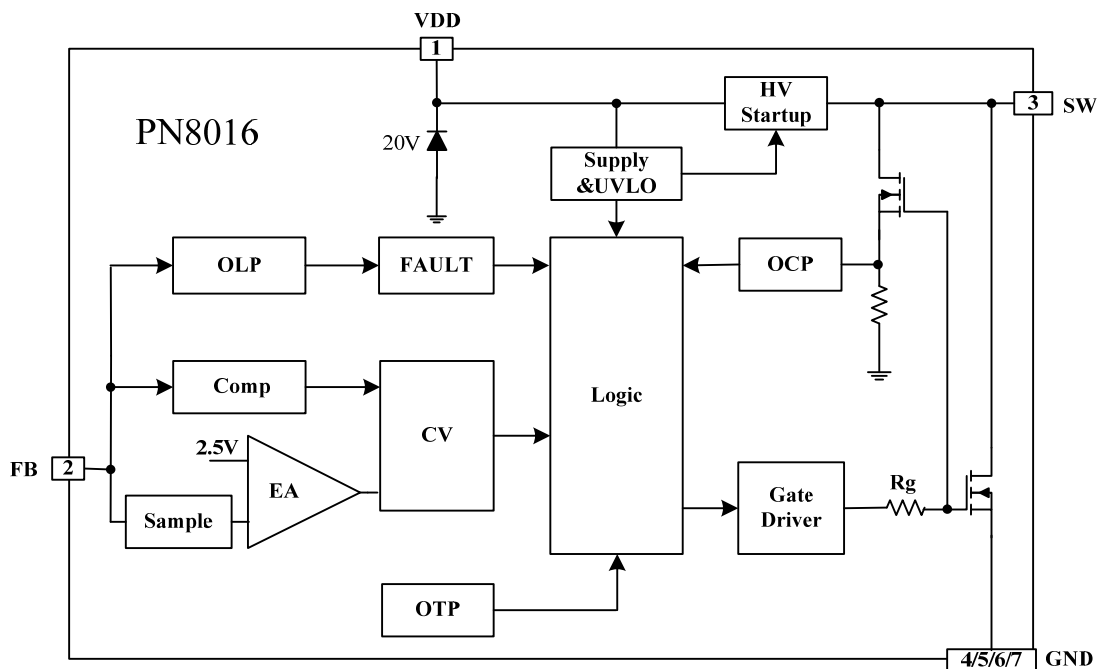

Absolute Maximum Ratings

Supply voltage Pin VDD.....	-0.3~40V	Lead Temperature (Soldering, 10Secs).....	260°C
High-Voltage Pin, SW.....	-0.3~750V	Package Thermal Resistance R _{θJC} (SOP-7).....	80°C/W
FB Pin.....	-0.3~7V	HBM ESD Protection ⁽¹⁾	±4kV
Operating Junction Temperature.....	-40~150°C	ESD voltage Protection ⁽²⁾	8kV
Storage Temperature Range.....	-55~150°C	Pulse Drain Current (T _{pulse} =100us)	2A

Note: 1. Test standard: ESDA/JEDEC JDS-001-2014.

2. Air discharge to pins of PN8016 with ESD Generator, Enterprise internal standards, for reference only.

Electrical Characteristics

(T_A = 25°C, V_{DD} = 15 V, unless otherwise specified)

PARAMETER	SYMBOL	CONDITIONS	MIN.	TYP.	MAX.	UNIT
Power Section						
Drain Break-down voltage	BVDSS	I _{SW} =250uA	750	820		V
Off-state drain current	I _{OFF}	V _{sw} =500V			100	μA
Drain-source on state resistance	R _{DSON}	I _{SW} = 400mA, T _J =25°C		10		Ω
Start up threshold	V _{SW_START}	V _{DD} =V _{DDon} - 1V		30		V
Supply Voltage Section						
VDD start up threshold	V _{DDon}		12	13.5	15	V
VDD under voltage shutdown threshold	V _{DDoff}		10	11	12	V
VDD voltage Hysteresis	V _{DDhys}			2.5		V
VDD clamp voltage	V _{DDclamp}		16	20	23	V
Supply Current Section						
VDD charge current	I _{DDch}	V _{DD} =9V		-2.5		mA
Operating supply current	I _{DD0}	V _{FB} =2V, V _{DD} =15V	150	330	450	uA
Off-state current	I _{DD1}	V _{FB} =2V, V _{DD} =11V	80	120	150	uA
Operating supply current, with protection tripping	I _{DDFAULT}	V _{DD} = 15V		150		uA
Current Sense Section						
Drain current limit	I _{limit}		490	540	590	mA
Leading edge blanking time	T _{LEB}			300		ns
Feedback Input Section						
Minimum turn OFF time	T _{offmin}		15	18	21	us
Minimum turn ON time	T _{onmax}		10	13	16	us
MOSFET feedback turn-on Reference Voltage	V _{REF}		2.45	2.5	2.55	V

PARAMETER	SYMBOL	CONDITIONS	MIN.	TYP.	MAX.	UNIT
OLP Reference Voltage	V_{REF_OLP}		1.55	1.7	1.85	V
OLP delay Time	T_{OLP}			150		ms
Thermal Shutdown Section						
OTP threshold	T_{SD}		135	150		°C
OTP Protect Hysteresis	T_{HYST}			30		°C

Typical Characteristics Plot

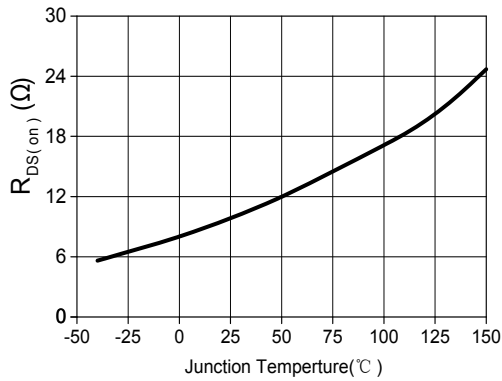

(a) $R_{DS(on)}$ vs T_j

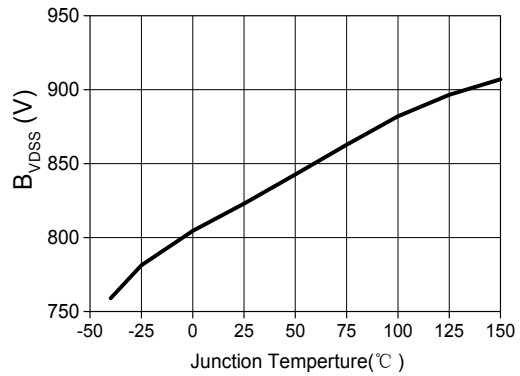

(b) BV_{DS} vs T_j

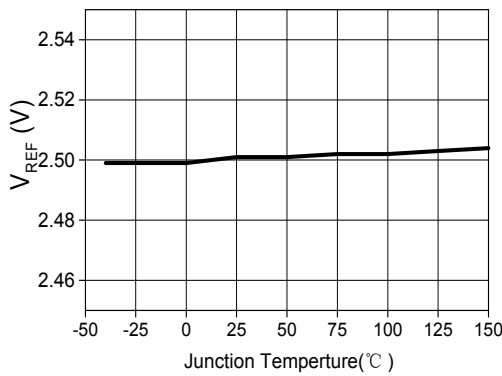

(c) V_{REF} vs T_j

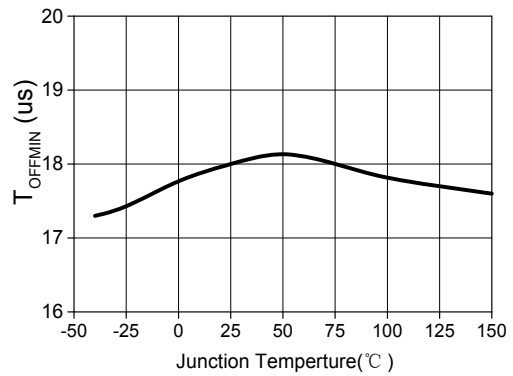

(d) T_{offmin} vs T_j

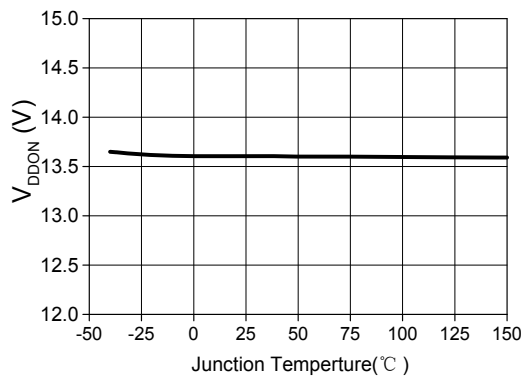

(e) $V_{DD(on)}$ vs T_j

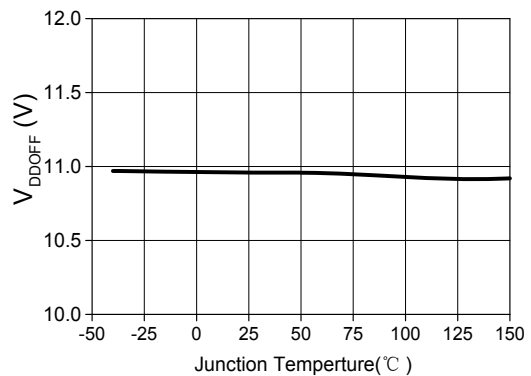

(f) $V_{DD(off)}$ vs T_j

Functional Description

The PN8016 consists of an integrated Pulse Width Modulator (PWM) controller and power MOSFET, specifically designed for small power non-isolated switching power supply. PN8016 offers fully intelligent protections including Over Load Protection (OLP), Under Voltage Lockout and Over Temperature Protection (OTP). Excellent EMI performance is achieved with Pulse Frequency Modulation. PN8016 also consists of the high voltage start-up circuit to ensure that start quickly.

1. Startup

At start up, the internal high-voltage current source supplies 2.5mA current to charges the external VDD capacitor. When VDD rises to V_{DDon} , PN8016 starts switching and the internal high-voltage current source stops charging the capacitor. When VDD drops to V_{DDoff} , PN8016 continues switching while the internal high-voltage current source returns to supplies 2.5mA current to charge the external VDD capacitor. The internal high-voltage regulator self-supplies the IC, so extra component is not needed for power supply.

2. CV Operation Mode

In CV operation, PN8016 samples the feedback signal through VDD pin. While the feedback voltage remains below V_{REF} , the IC turns on the integrated MOSFET. When the current of the inductor reaches the peak current limit (I_{peak}), the integrated MOSFET is turned off. Figure1-1 and Figure 1-2 shows the operating waveform of key nodes in continuous conduction mode (CCM) and discontinuous conduction mode (DCM). Meanwhile, the IC integrates load compensation function to improve load regulation and CV accuracy.

The output voltage of PN8016 can be adjusted by FB voltage dividing circuit. Use similar equation to determine the output voltage:

$$V_{Out} = 2.5V \times \frac{R_1 + R_2}{R_2}$$

(In actual applications, FB sampling voltage is affected by the forward drop of D3 in addition.)

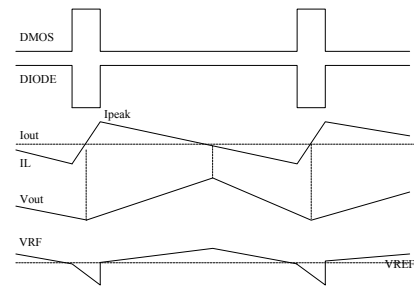

Figure 1-1 Waveform if CCM mode

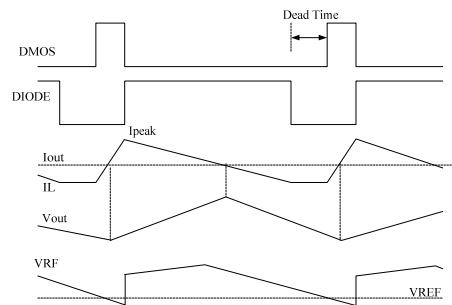

Figure 1-2 Waveform of DCM mode

3. PFM modulation

The IC operates in PFM mode, and I_{peak} is set to decrease with the decrease of the IC operating frequency (F_{sw}).when the IC switching cycle increase 1us, I_{peak} will decrease 6.0mA.As a result of the internal current sampling and the maximum current limit (I_{limit}), inductance is the only parameter of the frequency modulation when output voltage and output current are fixed.

4. Soft-Start up

In order to regulate peak current in deep CCM mode, PN8016 build in soft-start function, at the first 10ms of start up, the switching frequency decrease to 25% of the maximum frequency, while 10ms to 15ms of start up, the switching frequency decrease to 50% of the maximum frequency. Meanwhile, the leading edge blanking (LEB) is 300ns (Typ.), in order to regulate peak current.

5. Smart Protection Control

PN8016 has several smart self-protection functions, such as Over Load Protection(OLP),Over Temperature Protection(OTP),FB Open Loop

Detection(OLD),VDD Under-Voltage Lockout (UVLO).And all these protections have self-recovery mode.

OLP----If the FB pin voltage remains in lower than 1.7V for more than 150ms, the IC will self-restart.

OTP----If the inner junction temperature exceeds 150 °C ,the IC will shut down switching, until the junction temperature falls to 120°C.

OLD----If the FB pin voltage is lower than 100mV after soft-start up, the IC will self-restart.

UVLO----If VDD pin Voltage drops below 11V, the internal high-voltage current source returns to supply 2.5mA current to charge the external VDD capacitor until VDD rises to V_{DDon} . Otherwise, self-restart time can be changed by VDD capacitor. The larger the capacitor, the longer the self-restart time is.

Typical Application

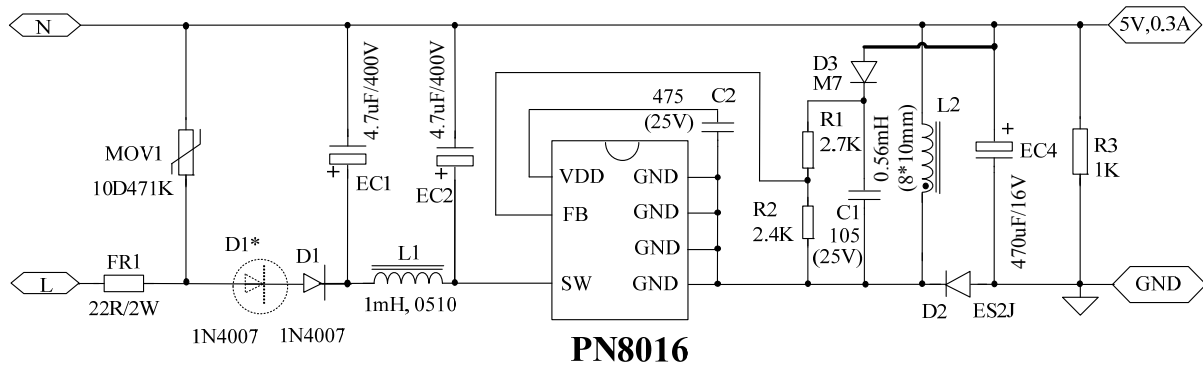

Component Parameter and Layout Considerations:

1. For 2KV differential mode surge, a diode D1* 1N4007 is recommended.
2. The pad between Pin 2 (VDD) and Pin 3 (SW) is not recommended for SOP-7 package of PN8016.

Package Information

SOP-7 Package Information

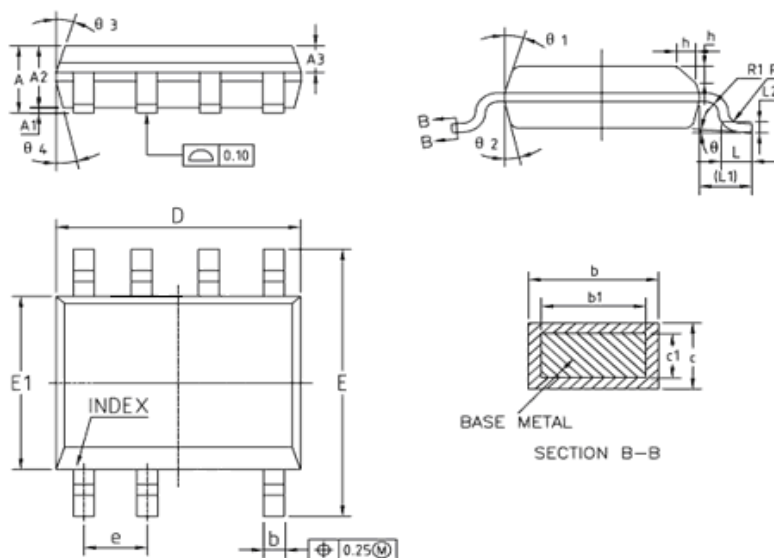

Size symbol	Min.(mm)	Nom.(mm)	Max.(mm)	Size symbol	Min.(mm)	Nom.(mm)	Max.(mm)
A	1.35	1.55	1.75	L	0.45	0.60	0.80
A1	0.10	0.15	0.25	L1	1.04REF		
A2	1.25	1.40	1.65	L2	0.25BSC		
A3	0.50	0.60	0.70	R	0.07	—	—
b	0.38	—	0.51	R1	0.07	—	—
b1	0.37	0.42	0.47	h	0.30	0.40	0.50
c	0.17	—	0.25	θ	0°	—	8°
c1	0.17	0.20	0.23	θ1	15°	17°	19°
D	4.80	4.90	5.00	θ2	11°	13°	15°
E	5.80	6.00	6.20	θ3	15°	17°	19°
E1	3.80	3.90	4.00	θ4	11°	13°	15°
e	1.270(BSC)						

Top mark	Package
PN8016 YWWXXXXX	SOP-7

Note: Y: Year Code; WW: Week Code; XXXXX: Internal Code

Notes:

1. This drawing is subjected to change without notice.
2. Body dimensions do not include mold flash or protrusion.

Tape and Reel Information

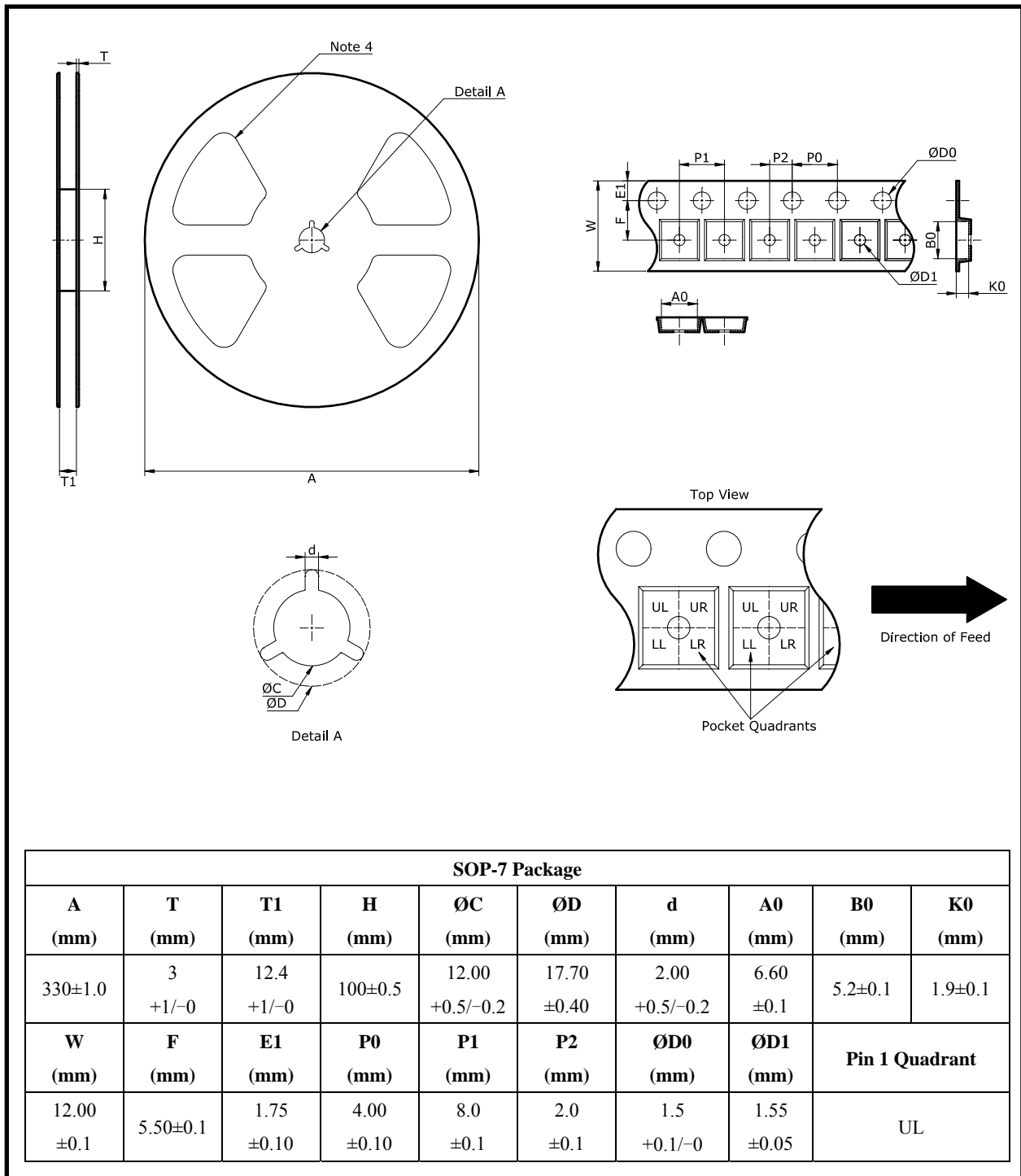

Notes:

1. This drawing is subjected to change without notice.
2. All dimensions are nominal and in mm.
3. This drawing is not in scale and for reference only. Customer can contact Chipown sales representative for further details.
4. The number of flange openings depends on the reel size and assembly site. This drawing shows an example only.

Important Notice

Wuxi Chipown Microelectronics Co. Ltd. reserves the right to make changes without further notice to any products or specifications herein. Wuxi Chipown Microelectronics Co. Ltd. does not assume any responsibility for use of any its products for any particular purpose, nor does Wuxi Chipown Microelectronics Co. Ltd assume any liability arising out of the application or use of any its products or circuits. Wuxi Chipown Microelectronics Co. Ltd does not convey any license under its patent rights or other rights nor the rights of others.