

## Automotive-grade high voltage ignition coil driver NPN power Darlington transistor

Datasheet - production data



Figure 1: Internal schematic diagram

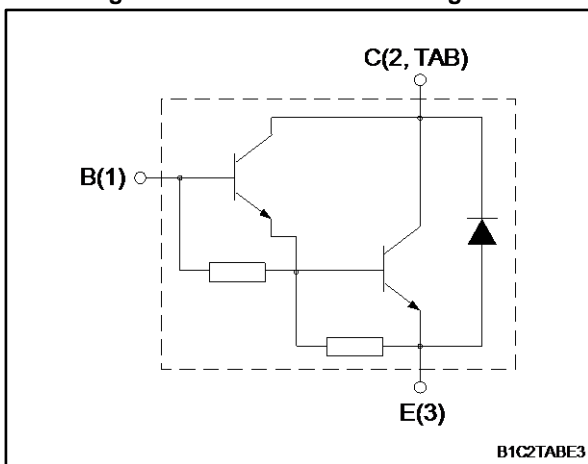

Table 1: Device summary

Order code	Marking	Package	Packing
BU931P	BU931P	TO-247	Tube

### Features

- AEC-Q101 qualified
- Very rugged Bipolar technology
- High operating junction temperature



### Applications

- High ruggedness electronic ignitions

### Description

This is a high voltage power Darlington transistor developed using multi-epitaxial planar technology. It has been properly designed for automotive environment as electronic ignition power actuators.

---

**Contents**

<b>1</b>	<b>Electrical ratings .....</b>	<b>3</b>
<b>2</b>	<b>Electrical characteristics .....</b>	<b>4</b>
	2.1 Electrical characteristics (curves) .....	5
<b>3</b>	<b>Test circuits .....</b>	<b>7</b>
<b>4</b>	<b>Package information .....</b>	<b>8</b>
	4.1 TO-247 package information .....	8
<b>5</b>	<b>Revision history .....</b>	<b>10</b>

# 1 Electrical ratings

**Table 2: Absolute maximum ratings**

Symbol	Parameter	Value	Unit
$V_{CES}$	Collector-emitter voltage ( $V_{BE} = 0$ )	500	V
$V_{CEO}$	Collector-emitter voltage ( $I_B = 0$ )	400	V
$V_{EBO}$	Emitter-base voltage ( $I_C = 0$ )	5	V
$I_C$	Collector current	15	A
$I_{CM}$	Collector peak current	30	A
$I_B$	Base current	1	A
$I_{BM}$	Base peak current	5	A
$P_{TOT}$	Total dissipation at $T_C = 25\text{ °C}$	135	W
$T_{stg}$	Storage temperature range	-65 to 175	°C
$T_j$	Operating junction temperature range		°C

**Table 3: Thermal data**

Symbol	Parameter	Value	Unit
$R_{thJC}$	Thermal resistance junction-case	1.1	°C/W
$R_{thJA}$	Thermal resistance junction-ambient	50	°C/W

## 2 Electrical characteristics

( $T_C = 25\text{ °C}$  unless otherwise specified)

**Table 4: Electrical characteristics**

Symbol	Parameter	Test conditions	Min.	Typ.	Max.	Unit
I <sub>CES</sub>	Collector cut-off current	V <sub>BE</sub> = 0 V, V <sub>CE</sub> = 500 V		-	100	μA
		V <sub>BE</sub> = 0 V, V <sub>CE</sub> = 500 V, T <sub>C</sub> = 125 °C <sup>(1)</sup>		-	0.5	mA
I <sub>CEO</sub>	Collector cut-off current	I <sub>B</sub> = 0 A, V <sub>CE</sub> = 450 V		-	100	μA
		I <sub>B</sub> = 0 A, V <sub>CE</sub> = 450 V, T <sub>C</sub> = 125 °C <sup>(1)</sup>		-	0.5	mA
I <sub>EBO</sub>	Emitter cut-off current	I <sub>C</sub> = 0 A, V <sub>EB</sub> = 5 V		-	20	mA
V <sub>CEO(sus)</sub> <sup>(2)</sup>	Collector-emitter sustaining voltage	I <sub>B</sub> = 0 A, I <sub>C</sub> = 100 mA	400	-		V
V <sub>CE(sat)</sub> <sup>(2)</sup>	Collector-emitter saturation voltage	I <sub>C</sub> = 7 A, I <sub>B</sub> = 70 mA		-	1.6	V
		I <sub>C</sub> = 8 A, I <sub>B</sub> = 100 mA		-	1.8	V
		I <sub>C</sub> = 10 A, I <sub>B</sub> = 250 mA		-	1.8	V
V <sub>BE(sat)</sub> <sup>(2)</sup>	Base-emitter saturation voltage	I <sub>C</sub> = 7 A, I <sub>B</sub> = 70 mA		-	2.2	V
		I <sub>C</sub> = 8 A, I <sub>B</sub> = 100 mA		-	2.4	V
		I <sub>C</sub> = 10 A, I <sub>B</sub> = 250 mA		-	2.5	V
h <sub>FE</sub> <sup>(2)</sup>	DC current gain	I <sub>C</sub> = 5 A, V <sub>CE</sub> = 10 V	300	-		
V <sub>F</sub>	Diode forward voltage	I <sub>F</sub> = 10 A		-	2.5	V
	Functional test	V <sub>CC</sub> = 24 V, L = 7 mH, V <sub>clamp</sub> = 400 V (see <a href="#">Figure 10: "Functional test circuit"</a> )	8	-		A

**Notes:**

<sup>(1)</sup>Defined by design, not subject to production test.

<sup>(2)</sup>Pulse test: pulse duration ≤ 300 μs, duty cycle ≤ 2 %.

**Table 5: Inductive load switching times**

Symbol	Parameter	Test conditions	Min.	Typ.	Max.	Unit
t <sub>s</sub>	Storage time	V <sub>BE</sub> =0, V <sub>CC</sub> = 12 V, V <sub>clamp</sub> = 300 V, L = 7 mH, R <sub>BE</sub> = 47 Ω, I <sub>C</sub> = 7 A, I <sub>B</sub> = 70 mA (see <a href="#">Figure 12: "Switching time test circuit"</a> )	-	15	-	μs
t <sub>f</sub>	Fall time		-	0.5	-	μs

## 2.1 Electrical characteristics (curves)

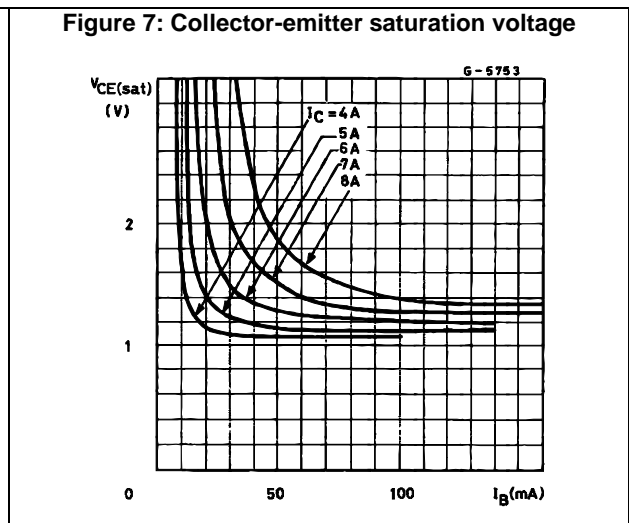
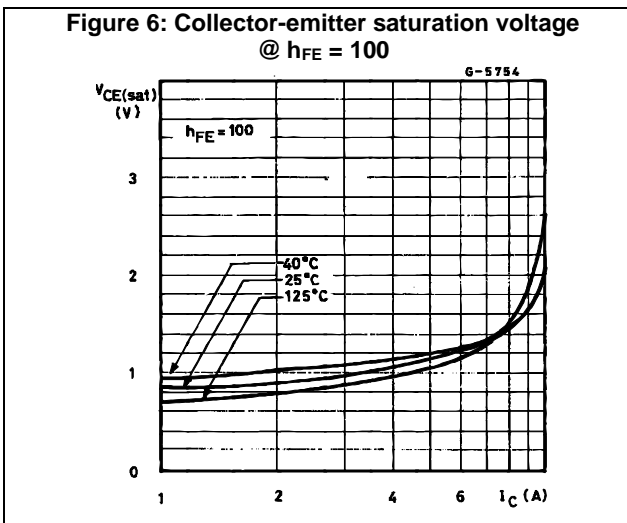
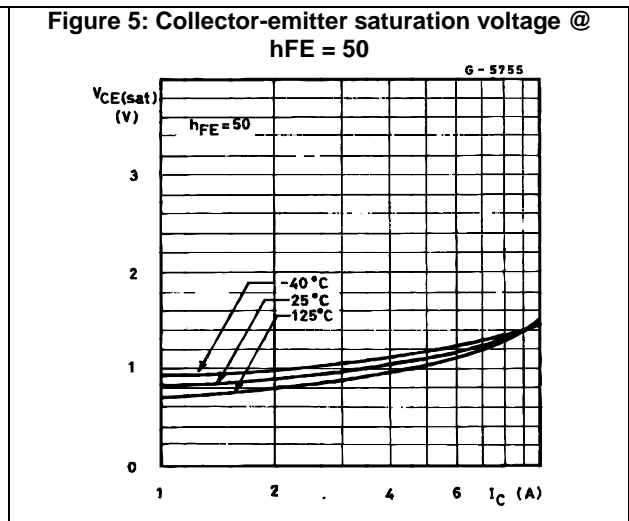
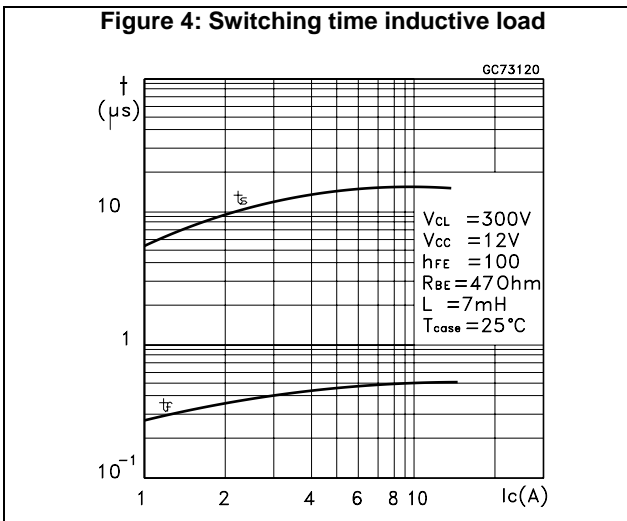
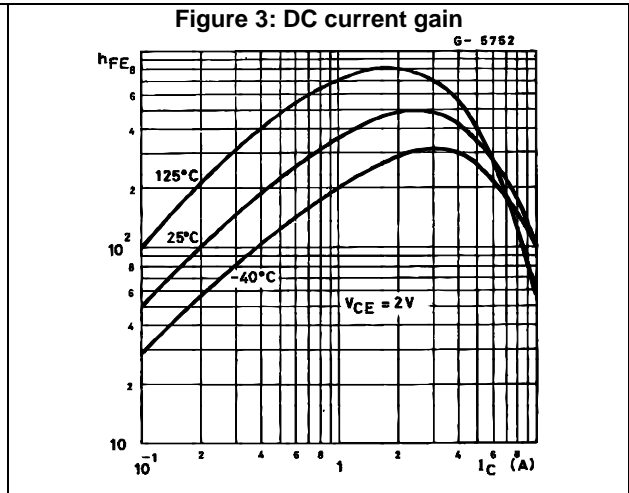
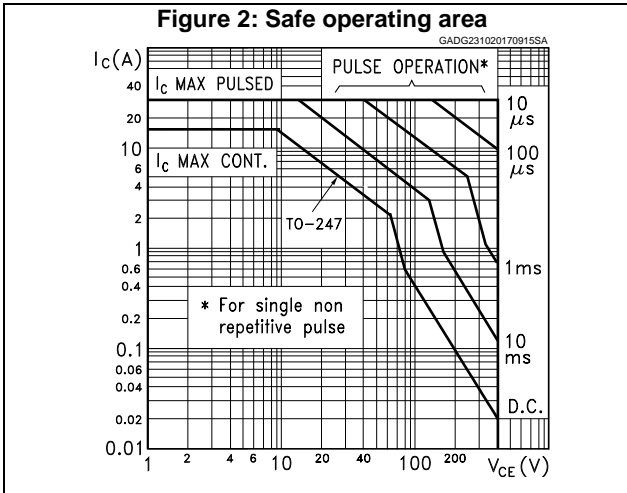

Figure 8: Base-emitter saturation voltage  
@  $h_{FE} = 50$

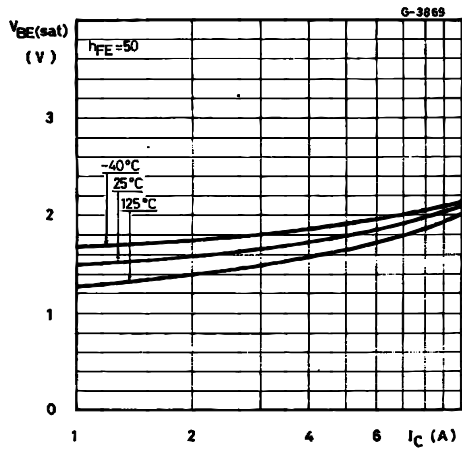
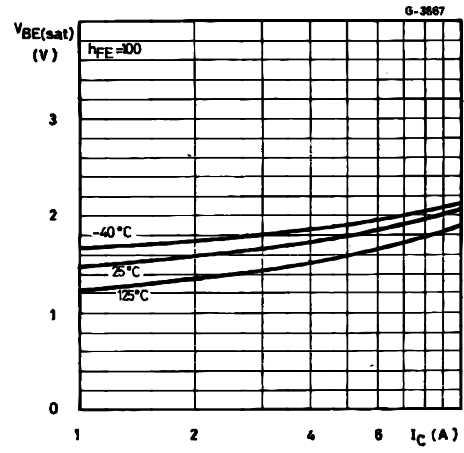

Figure 9: Base-emitter saturation voltage  
@  $h_{FE} = 100$



### 3 Test circuits

Figure 10: Functional test circuit

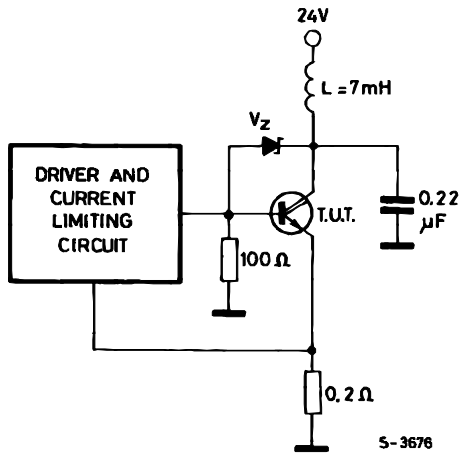

Figure 11: Functional test waveforms

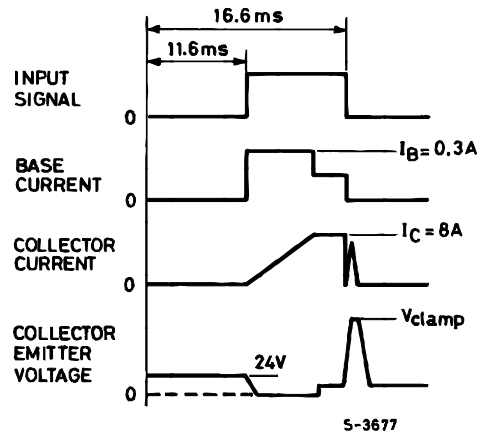

Figure 12: Switching time test circuit

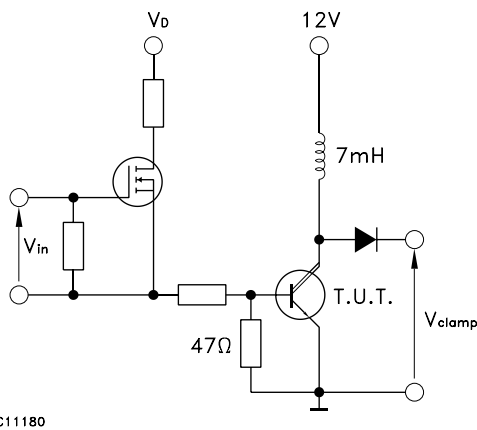
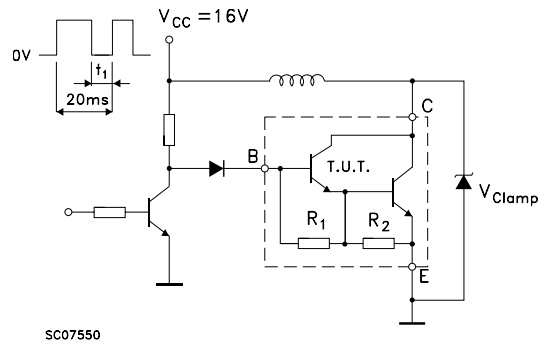

Figure 13: Sustaining voltage test circuit



## 4 Package information

In order to meet environmental requirements, ST offers these devices in different grades of ECOPACK® packages, depending on their level of environmental compliance. ECOPACK® specifications, grade definitions and product status are available at: [www.st.com](http://www.st.com). ECOPACK® is an ST trademark.

### 4.1 TO-247 package information

Figure 14: TO-247 package outline

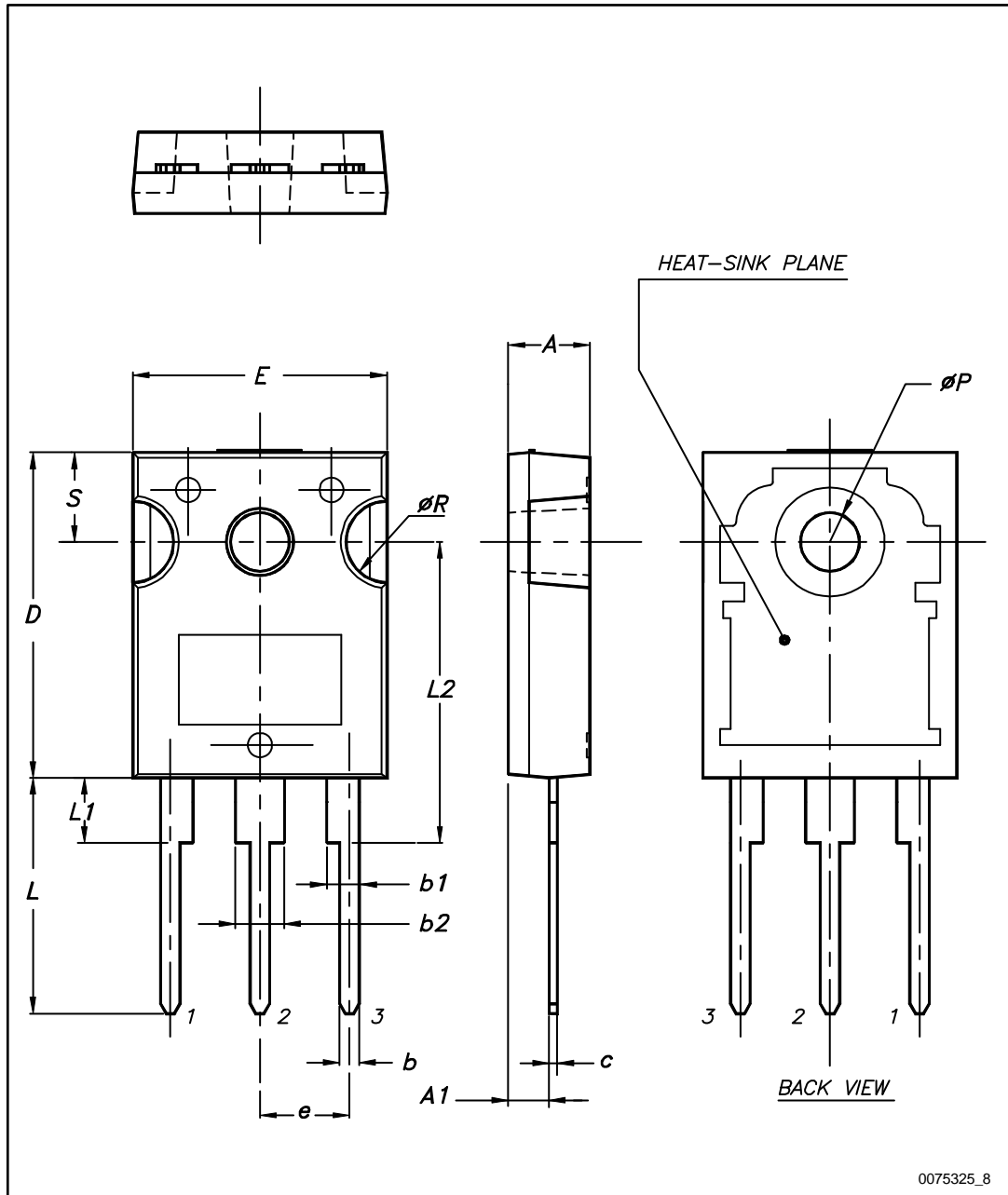



Table 6: TO-247 package mechanical data

Dim.	mm		
	Min.	Typ.	Max.
A	4.85		5.15
A1	2.20		2.60
b	1.0		1.40
b1	2.0		2.40
b2	3.0		3.40
c	0.40		0.80
D	19.85		20.15
E	15.45		15.75
e	5.30	5.45	5.60
L	14.20		14.80
L1	3.70		4.30
L2		18.50	
ØP	3.55		3.65
ØR	4.50		5.50
S	5.30	5.50	5.70

## 5 Revision history

Table 7: Document revision history

Date	Revision	Changes
23-Oct-2017	1	Initial release. Part number previously included in datasheet DocID1004.

**IMPORTANT NOTICE – PLEASE READ CAREFULLY**

STMicroelectronics NV and its subsidiaries ("ST") reserve the right to make changes, corrections, enhancements, modifications, and improvements to ST products and/or to this document at any time without notice. Purchasers should obtain the latest relevant information on ST products before placing orders. ST products are sold pursuant to ST's terms and conditions of sale in place at the time of order acknowledgement.

Purchasers are solely responsible for the choice, selection, and use of ST products and ST assumes no liability for application assistance or the design of Purchasers' products.

No license, express or implied, to any intellectual property right is granted by ST herein.

Resale of ST products with provisions different from the information set forth herein shall void any warranty granted by ST for such product.

ST and the ST logo are trademarks of ST. All other product or service names are the property of their respective owners.

Information in this document supersedes and replaces information previously supplied in any prior versions of this document.

© 2017 STMicroelectronics – All rights reserved