

Motor Driver for Portable DVD player with DC-DC Step Down Converter AM5898N

The AM5898N is a 4-channel BTL driver IC for driving the motors and actuators such as used in DVD player and consists of two DC-DC Step Down Converters. It is pretty fit for portable DVD player application. Package material is Pb Free for environmental protection.

- **Applications**

BTL driver for portable DVD player with DC-DC power management.

- **Features**

- (A) **4-channel BTL:**

- 1) Two channels are voltage-type BTL drivers for actuators of tracking and focus. Two channels are voltage-type BTL driver for sled and spindle motors. It is also built-in two DC-DC converters.
 - 2) Wide dynamic range for motor drive [3.6V (*typ.*) when $V_{cc}=5V$, at $R_L=20\ \Omega$ load].

- (B) **2 DC-DC Step down converters:**

- 1) Efficiency up to 85%
 - 2) Operation from 4.5~16V
 - 3) Typical frequency operation to 240KHz.
 - 4) Over voltage protection built-in.
 - 5) Over current protection built-in.

- (C) **Common circuit**

- 1) Level shift circuit built-in.
 - 2) Thermal shut down circuit built-in.
 - 3) Mute mode built-in for motor drive. EN1, EN2 mode control for two set of DC-DC step down converters.

● Absolute maximum ratings (Ta=25°C)

Parameter	Symbol	Limits	Unit
Supply voltage 1 for driver	Vcc1	13.5	V
Supply voltage 2 for driver	Vcc2	13.5	V
Supply voltage for converter	PVcc	26	V
Power dissipation	P _d	2.2 ^{*1}	W
Operate Temp range	T _{opr}	-40 ~ +85	
Storage Temp range	T _{stg}	** -55 ~ +150	

*70mm×70mm×1.6mm glass epoxy board.

* 1.Derating: 17.6mW/°C for operation above Ta=25°C

● Guaranteed operating conditions (Ta=25°C)

Parameter	Symbol	Limits	Unit
Power supply voltage	Vcc1	4.3 ~ 13.2	V
	Vcc2	4.3 ~ Vcc1	V
	PVcc	4.5 ~ 16	V

● Block diagram

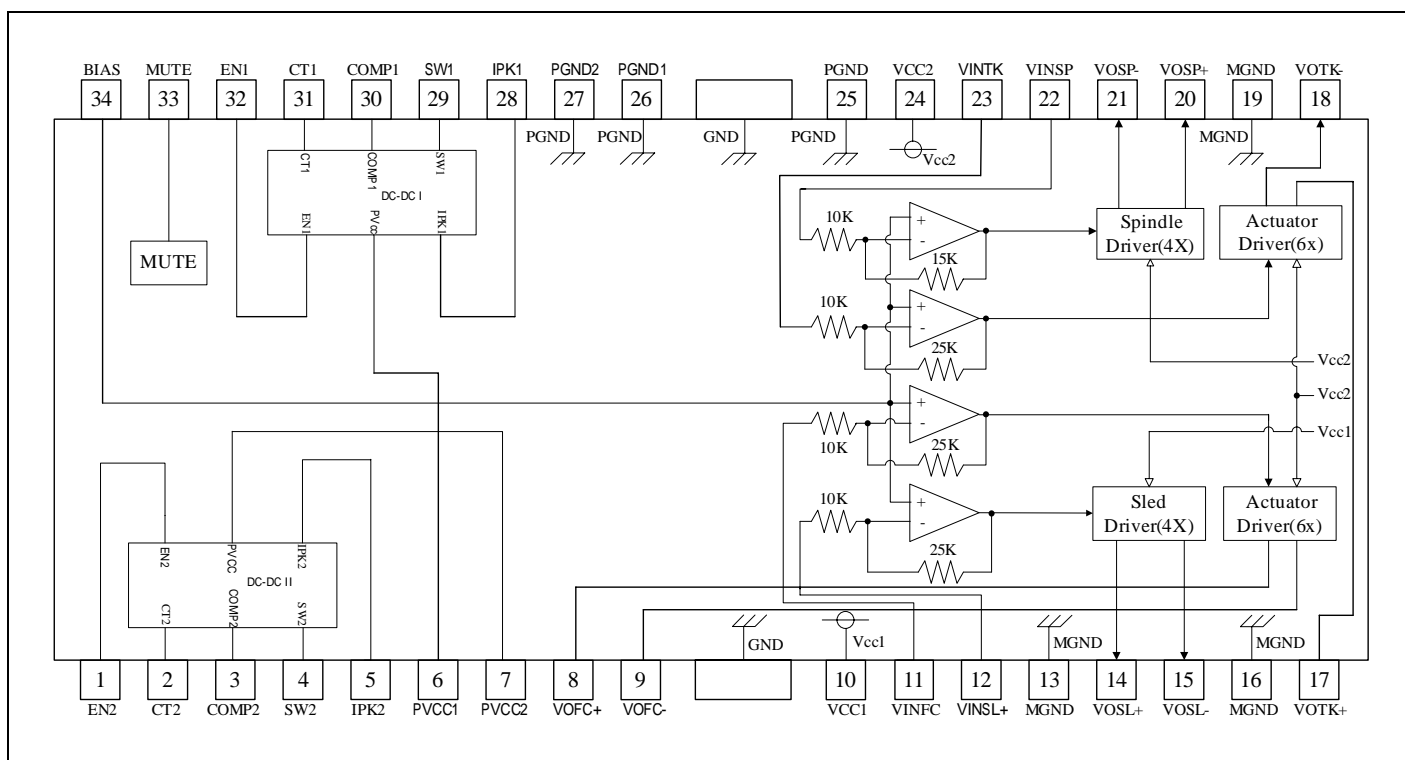

● **Electrical characteristics**

(Unless otherwise specified $T_a=25^\circ\text{C}$, $V_{cc1}=5\text{V}$, $V_{cc2}=5\text{V}$, $PV_{cc}=12\text{V}$, $\text{BIAS}=1.65\text{V}$, $R_L=8\ \Omega/10\ \Omega/20\ \Omega$)

Parameter	Symbol	Limit			Unit	Conditions	P.S
		Min	Typ	Max			
Quiescent current	I_{cc}	-	19	-	mA		
Standby current 1	I_{stb1}	-	3	-	mA	Mute = L, EN1 = H, EN2 = H	
Standby current 2	I_{stb2}	-	15	-	mA	Mute = H, EN1 = L, EN2 = L	
Standby current 3	I_{stb3}	-	140	200	uA	Mute = L, EN1 = L, EN2 = L	
Voltage for mute ON	V_{ston}	0	-	0.5	V		
Voltage for mute OFF	V_{stoff}	2.0	-	5	V		
Voltage for EN low	V_{ENL}	0	-	0.5	V		
Voltage for EN High	V_{ENH}	2.0	-	5	V		
<Actuator drivers>							
Output offset voltage	V_{oo}	-	-	± 50	mV		
Maximum output voltage	V_{om}	-	3.4	-	V	@10 Load	
Voltage gain	G_v	21.5	23.5	25.5	dB	$V_{IN}=\text{BIAS}+0.2V_{pp}$ ac @1KHz	
<Sled motor driver>							
Output offset voltage	V_{oofsl}	-	-	± 100	mV		
Maximum output voltage	V_{omsl}	-	3.6	-	V	@20 Load	
Closed loop voltage gain	G_{vsl}	18	20	22	dB	$V_{IN}=\text{BIAS}+0.2V_{pp}$ ac @1KHz	
<Spindle motor driver>							
Output offset voltage	V_{oofld}	-	-	± 50	mV		
Maximum output voltage	V_{omax}	-	3.2	-	V	@8 Load	
Voltage gain	G_{vld}	13.5	15.5	17.5	dB	$V_{IN}=\text{BIAS}+0.2V_{pp}$ ac @1KHz	
Gain error by polarity	G_{vld}	0	1	2	dB	$V_{IN}=\text{BIAS}+0.2V_{pp}$ ac @1KHz	
<Step down converter>							
Oscillator Frequency	F_{osc}	-	240	-	KHz	CT=68PF	
Charge Current	I_{chg}	-	24	-	uA		
Discharge Current	I_{dischg}	-	144	-	uA		
Current Limit Sense Voltage	V_{ipk}	-	200	-	mV	$R_{sc}=0.1$	
Comparator Threshold Voltage	V_{th}	-	1.25	-	V		
Output Source Current	I_{source}	-	180	-	mA	$V_{out}=0V$	
Output Sink Current	I_{sink}	-	120	-	mA	$V_{out}=9V$	

*This device is not designed for protection against radioactive rays.

● Pin configuration

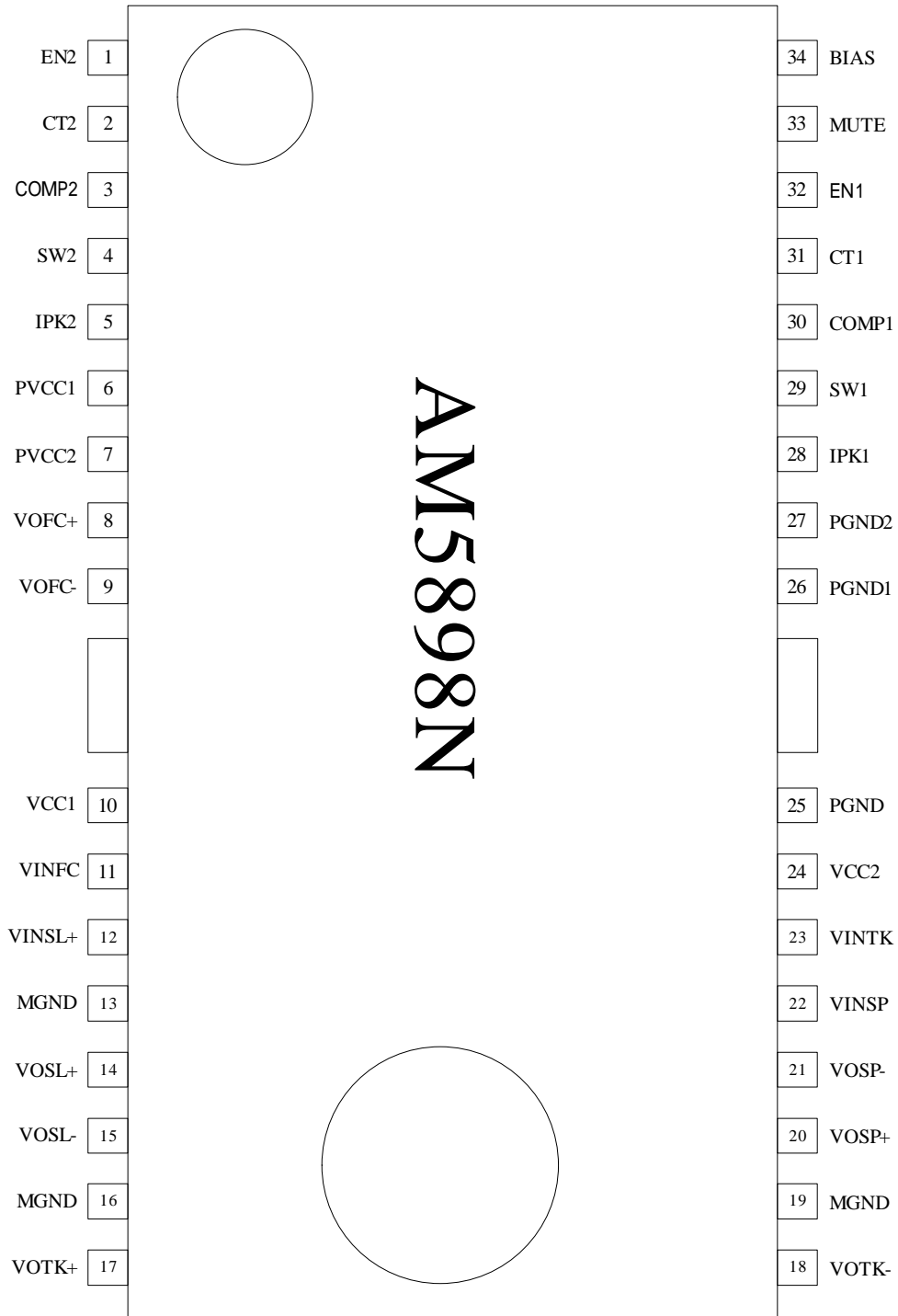

● Pin description

PIN No	Pin Name	Function
1	EN2	Enable pin for buck converter 2
2	CT2	Timing capacitor input 2
3	COMP2	Comparator inverting input 2
4	SW2	Switching output 2
5	IPK2	Current sense 2
6	PVcc1	Vcc for step down converter 1
7	PVcc2	Vcc for step down converter 2
8	VOFC+	Focus driver output (+)
9	VOFC-	Focus driver output (-)
10	Vcc1	Vcc for power block of sled
11	VINFC	Input for focus driver
12	VINSL+	Input for the sled driver
13	MGND	Ground for motor driver
14	VOSL+	Sled driver output (+)
15	VOSL-	Sled driver output (-)
16	MGND	Ground for motor driver
17	VOTK+	Tracking driver output (+)
18	VOTK-	Tracking driver output (-)
19	MGND	Ground for motor driver
20	VOSP+	Spindle driver output (+)
21	VOSP-	Spindle driver output (-)
22	VINSP	Input for spindle driver
23	VINTK	Input for tracking driver
24	Vcc2	Vcc for power block of spindle , tracking and focus
25	PGND	Ground for analog ground
26	PGND1	Ground for step down converter 1
27	PGND2	Ground for step down converter 2
28	IPK1	Current sense 1
29	SW1	Switching output 1
30	COMP1	Comparator inverting input 1
31	CT1	Timing capacitor input 1
32	EN1	Enable pin for buck converter 1
33	MUTE	Input for mute control
34	BIAS	Input for reference voltage

Notes) Symbol of + and – (output of drivers) means polarity to input pin.
(For example, if voltage of pin10 is high, pin11 is high.)

● Power dissipation curve :

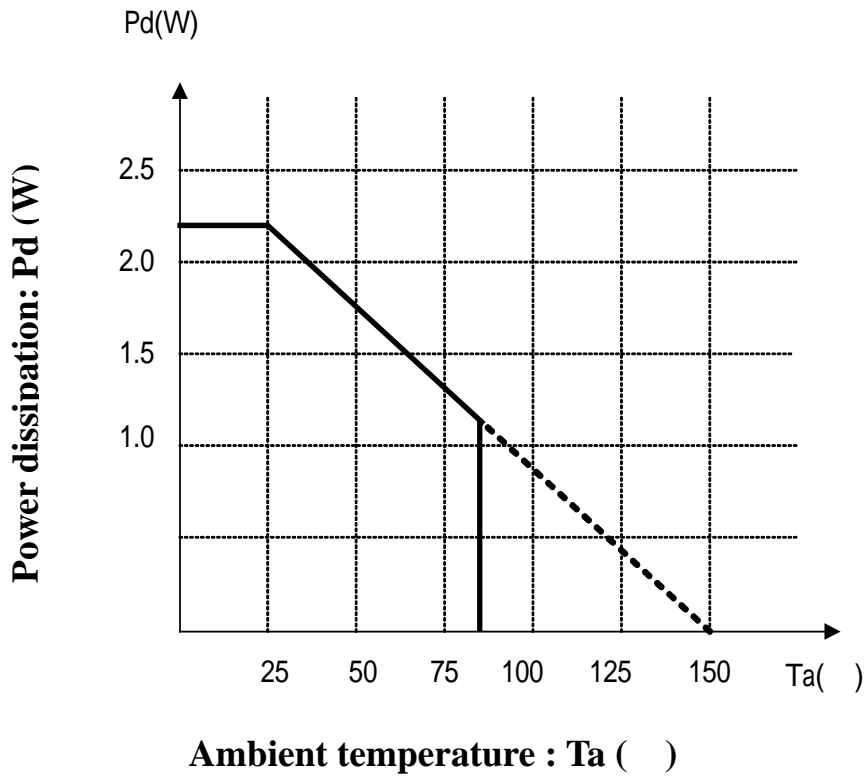

*70mm×70mm×1.6mm glass epoxy board.

*De-rating is done at 17.6mW/°C for operating above $T_a=25$

● **Operation notes**

- 1) The built-in thermal shutdown circuit mutes the output current of 4-channel BTL when the chip temperature reaches 175 (typ.). The hysteresis is set to 25 (typ.), so the circuit will start up again when the chip temperature falling to 150 (typ.).
- 2) In case mute pin voltage is under 0.5V or NC, output current is muted (except two DC-DC converter). Mute pin voltage should be more than 2.0V for normal application.
- 3) In case EN pin voltage is under 0.5V or NC, the converter circuit will stop operation. EN pin voltage should be more than 2.0V for normal application.
- 4) Bias pin (pin 34) should be pulled up to more than 1.2V. In case the bias pin voltage is pulled down below 0.9V (typ.), the output current of 4-channel BTL is muted.
- 5) Heat dissipation fins are attached to the GND on the inside of the package. Make sure to connect them to the external GND.
- 6) DC-DC Step down converter: Please refer to application note.
- 7) Truth table of Mute, EN1, EN2

Truth table (: active × : inactive -- : don't care)

Mute	EN 1	EN 2	Motor Channel	DC-DC ctrl I	DC-DC ctrl II
H	--	--		--	--
--	H	--	--		--
--	--	H	--	--	
L	L	L	×	×	×

● Application circuit

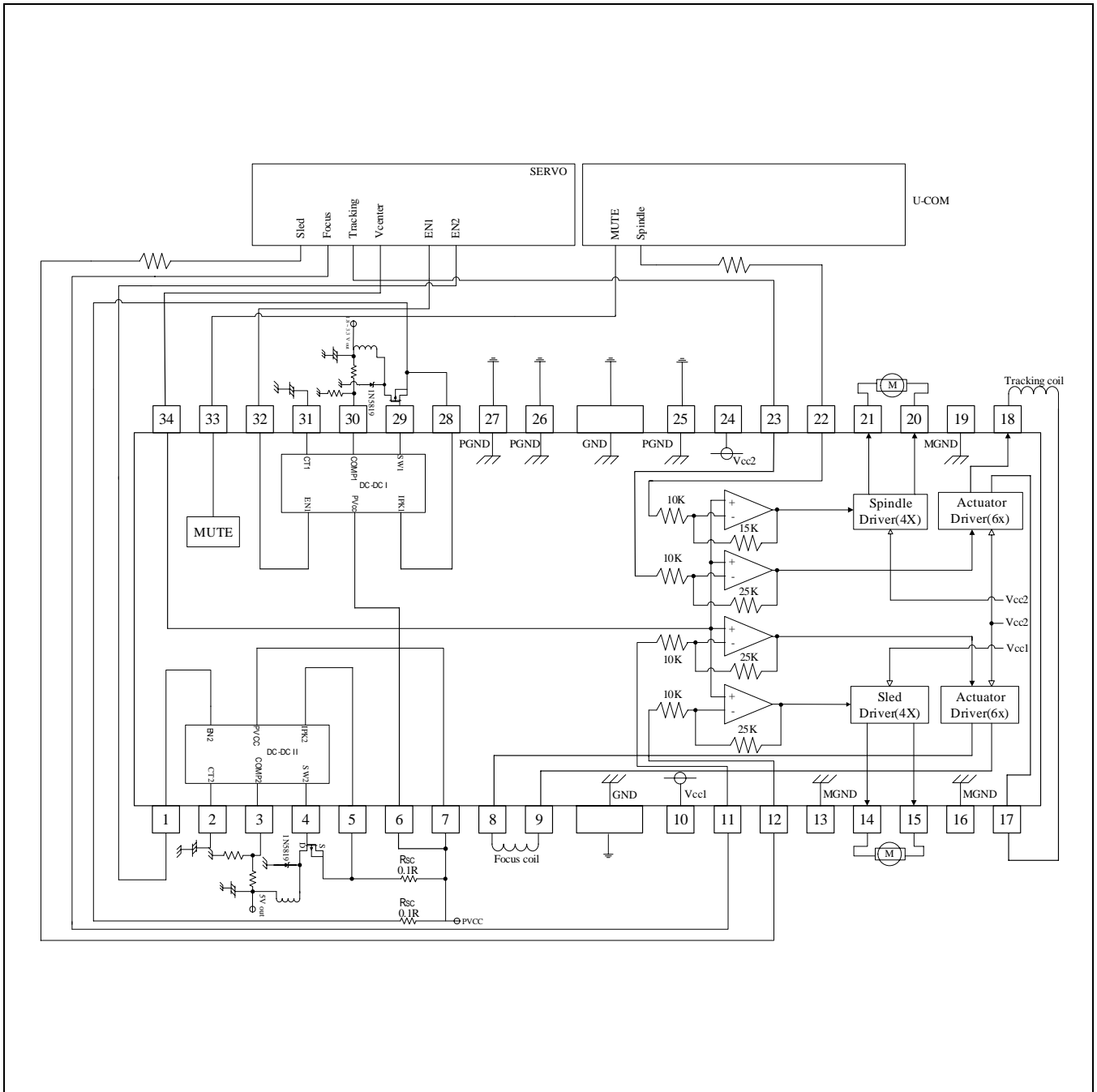

● Testing circuit

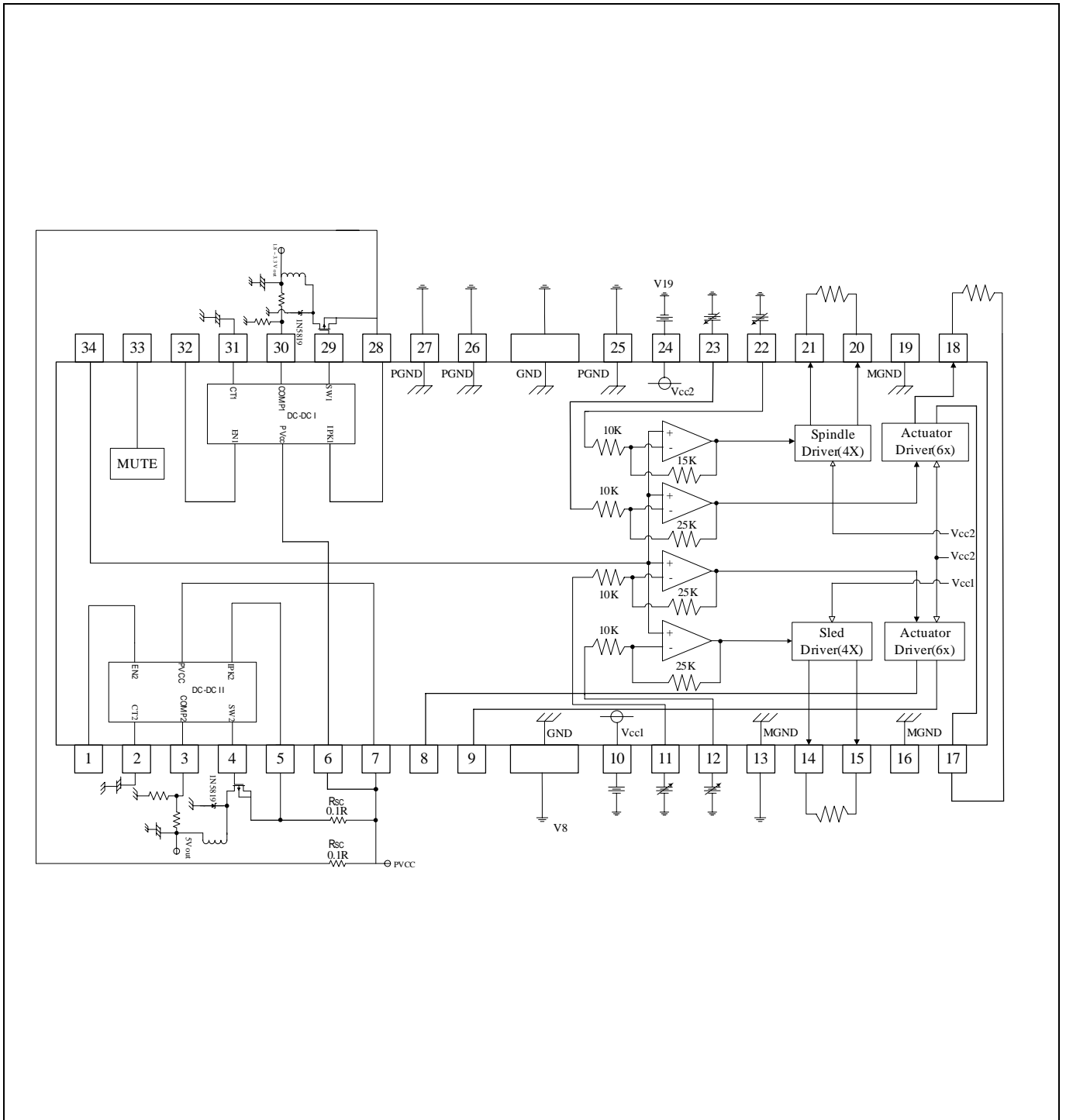

● Packaging outline

HSOP34

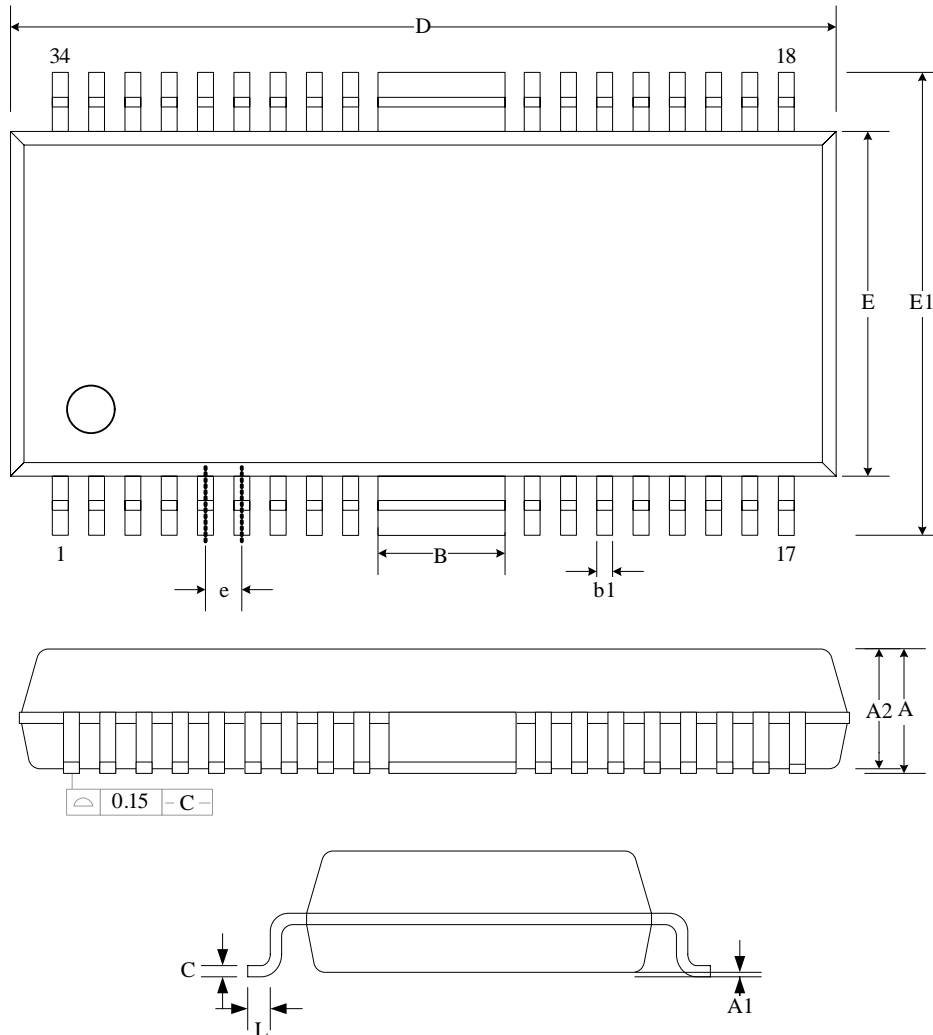

SYMBOL	MILLIMETERS		INCHES	
	Min.	Max.	Min.	Max.
A	-	2.75	-	0.108
A1	-	0.3	-	0.012
A2	-	2.45	-	0.096
B	2.55	2.95	0.1	0.16
b1	0.23	0.47	0.009	0.019
C	0.2	0.36	0.008	0.014
D	17.89	18.8	0.704	0.740
E	7.3	7.9	0.287	0.311
E1	9.6	10.65	0.378	0.419
e	0.8 (TYP)		0.031 (TYP)	
L	0.3	1.27	0.012	0.05

● **Marking Identification**

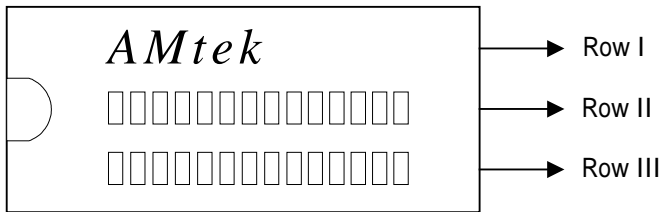

Row I

AMtek

Row II

AM5898N

Row III

Lot number