

PIN ASSIGNMENT											
A12	A11	A10	A9	A8	A7	A6	A5	A4	A3	A2	A1
GND	RX2+	RX2-	Vbus	Sbu1	D-	D+	CC	Vbus	TX1-	TX1+	GND
GND	TX2+	TX2-	Vbus	Vconn			Sbu2	VbuS	RX1-	RX1+	GND
B1	B2	B3	B4	B5			B8	B9	B10	B11	B12

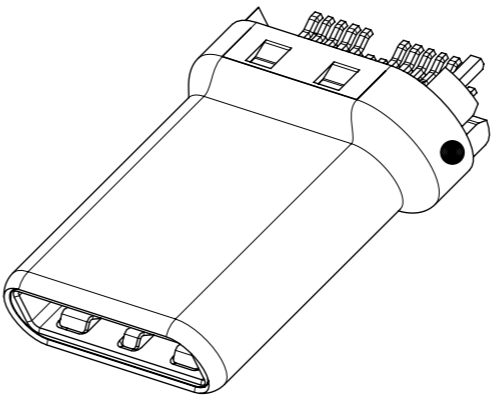

- NOTES:
- MATERIAL:
    - HOUSING: THERMOPLASTIC, UL94-V0; COLOR:BLACK;
    - INSERT MOLDING HOUSING: THERMOPLASTIC, UL94-V0;COLOR:BLACK;
    - TERMINAL: COPPER ALLOY;
    - OUTTER SHELL:STAINLESS STEEL;
    - FRONT SPRING::STAINLESS STEEL;
    - MIDDLE LATCH:STAINLESS STEEL;
    - ISOLATED LAYER:MYLAR;
  - FINISH:
    - TERMINAL:
      - 80 MICROINCH MIN. NICKEL UNDERPLATING OVERALL,
      - 120 MICROINCH MIN. TIN PLATING ON SOLDERING AREA;;
      - PLEASE REFER TO TABLE FOR CONTACT AREA PLATING;
    - OUTTER SHELL:
      - 50 MICROINCH MIN. BRIGHT NICKEL UNDERPLATING OVERALL,
    - FRONT SPRING:
      - 50 MICROINCH MIN. NICKEL UNDERPLATING OVERALL;
    - MIDDLE LATCH:
      - 50 MICROINCH MIN. NICKEL UNDERPLATING OVERALL;
  - PRODUCT SPECIFICATION:1054440001
  - PACKAGE SPECIFICATION:1054440001(PACKAGE WIHT TRARY)
  - PACKAGE SPECIFICATION:1054441001(PACKAGE WIHT TAPE AND REEL)

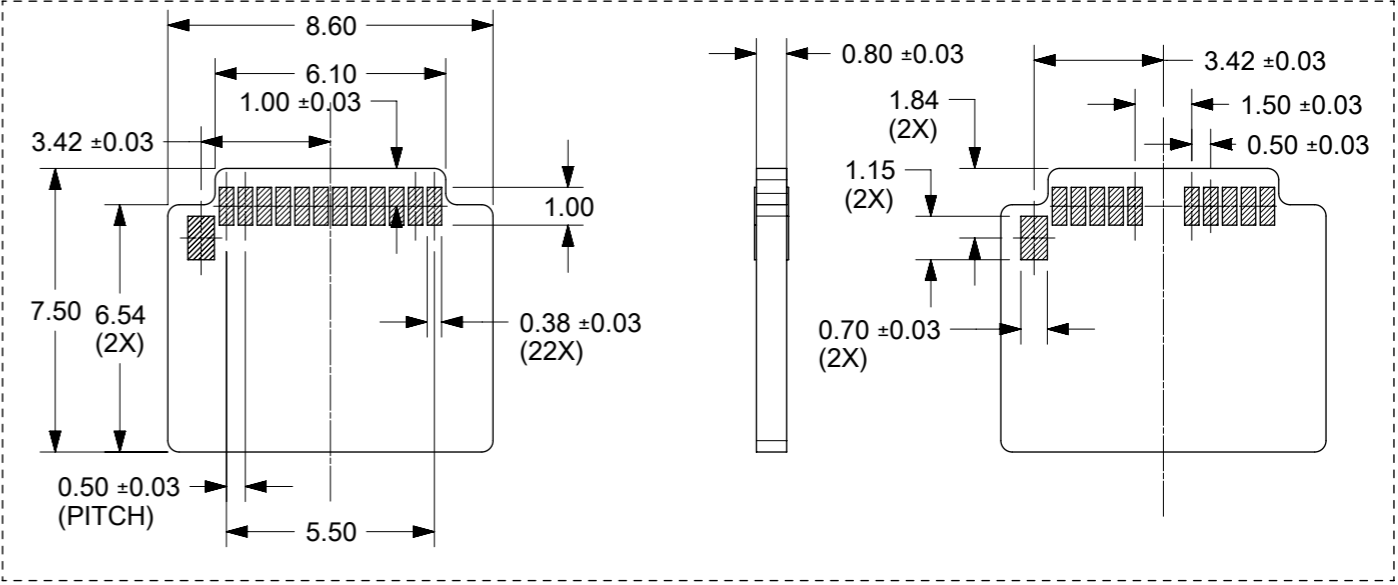
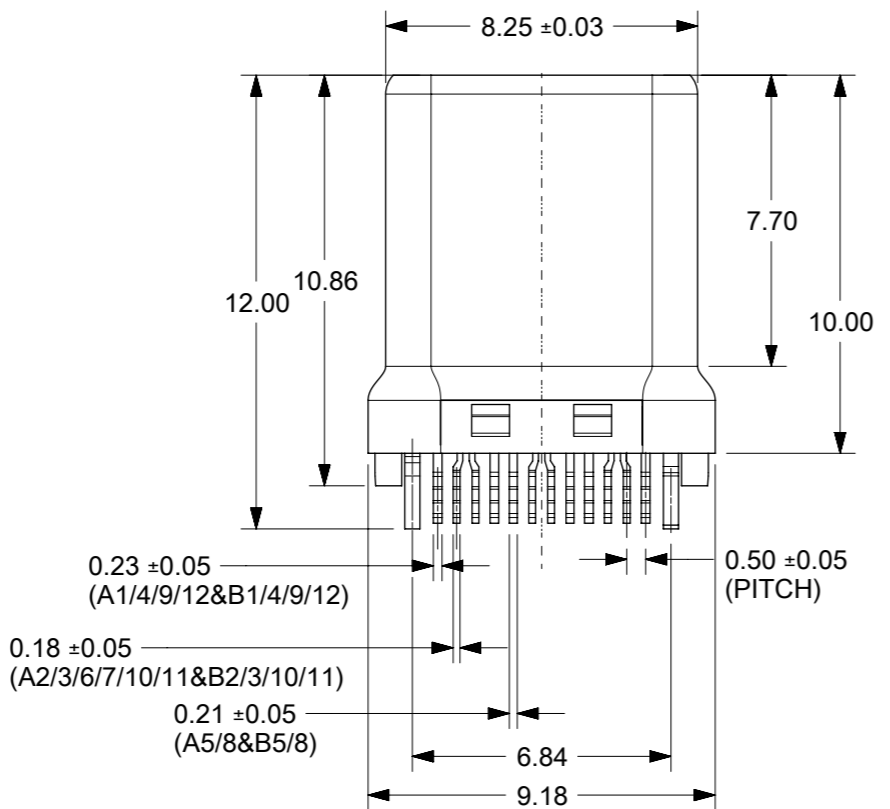
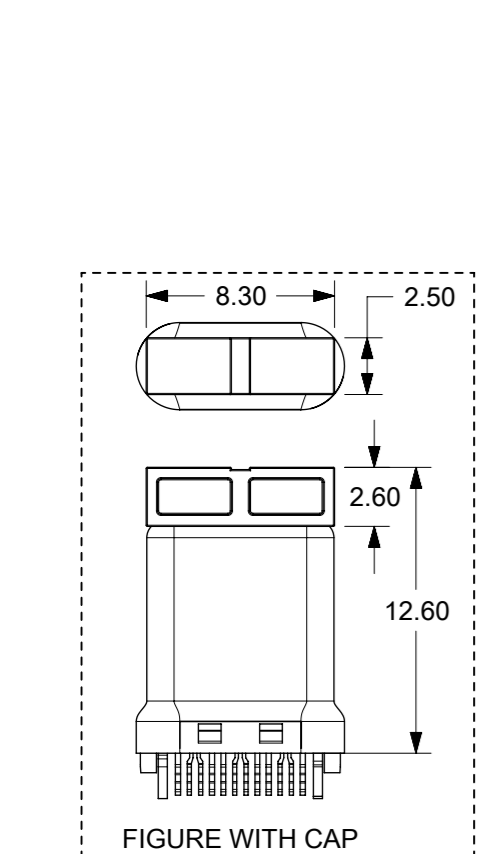
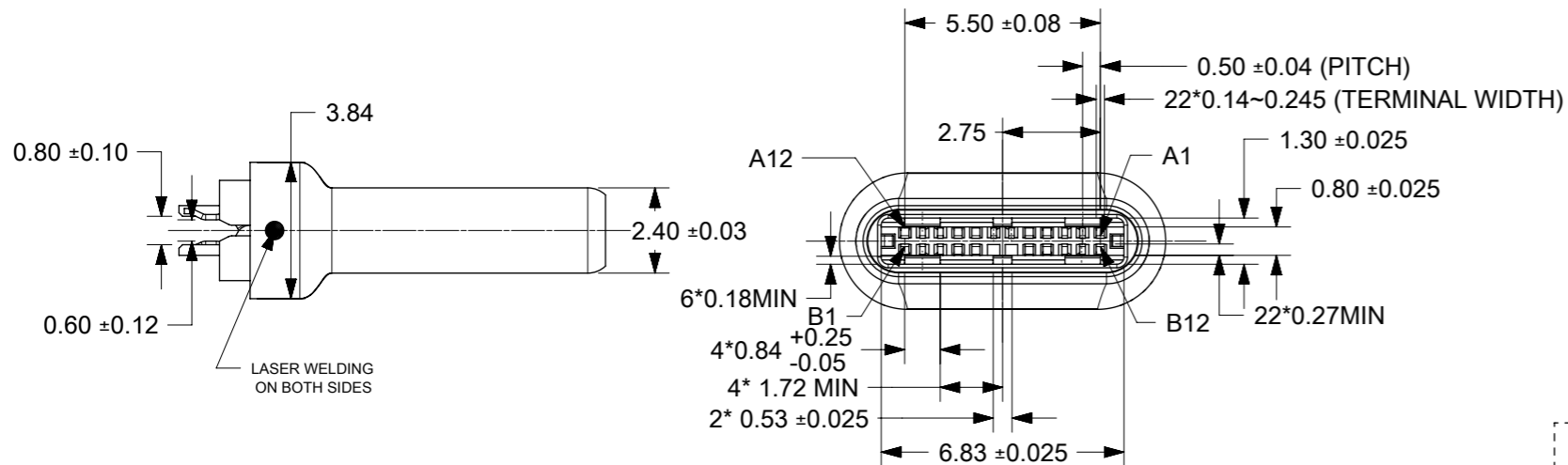

RECOMMENDED PCB LAYOUT  
(DEFAULT TOLERANCE :+/-0.05)

PART NUMBER	PLATING ON TERMINAL CONTACT AREA	PACAGE TYPE
1054440001	30 MICROINCH MIN. GOLD PLATING	TRAY
1054440011	30 MICROINCH MIN. GOLD PLATING	TAPE AND REEL

THIS DRAWING CONTAINS INFORMATION THAT IS PROPRIETARY TO MOLEX ELECTRONIC TECHNOLOGIES, LLC AND SHOULD NOT BE USED WITHOUT WRITTEN PERMISSION											
DIMENSION UNITS <b>mm</b>		SCALE <b>8:1</b>		CURRENT REV DESC: REMOVED OBSOLETE PART NUMBER AS PER PCN#511695.							
GENERAL TOLERANCES (UNLESS SPECIFIED)											
ANGULAR TOL		± °		EC NO: 730178						<b>USB C PLUG,SPLINT</b>	
4 PLACES		±		DRWN: SANTHN 2022/11/30							
3 PLACES		±		CHK'D: GGA 2023/01/04						<b>PRODUCT CUSTOMER DRAWING</b>	
2 PLACES		± 0.25		APPR: GGA 2023/01/04							
1 PLACE		± 0.25		INITIAL REVISION:						<b>1054440001</b>	
0 PLACES		±		DRWN: FYANG05 2015/11/26							
DRAFT WHERE APPLICABLE MUST REMAIN WITHIN DIMENSIONS		THIRD ANGLE PROJECTION		DRAWING		SERIES		MATERIAL NUMBER		CUSTOMER	
				A3-SIZE		105444		SEE TABLE		GENERAL MARKETING	
DOCUMENT STATUS		P1		RELEASE DATE		2023/01/04		04:25:04		DOC TYPE PSD DOC PART SM REVISION C2 SHEET NUMBER 1 OF 1	