

# RA6T2 Group

## MCK-RA6T2 User's Manual

### Renesas RA Family RA6 Series

All information contained in these materials, including products and product specifications, represents information on the product at the time of publication and is subject to change by Renesas Electronics Corp. without notice. Please review the latest information published by Renesas Electronics Corp. through various means, including the Renesas Electronics Corp. website (<http://www.renesas.com>).

## Notice

1. Descriptions of circuits, software and other related information in this document are provided only to illustrate the operation of semiconductor products and application examples. You are fully responsible for the incorporation or any other use of the circuits, software, and information in the design of your product or system. Renesas Electronics disclaims any and all liability for any losses and damages incurred by you or third parties arising from the use of these circuits, software, or information.
2. Renesas Electronics hereby expressly disclaims any warranties against and liability for infringement or any other claims involving patents, copyrights, or other intellectual property rights of third parties, by or arising from the use of Renesas Electronics products or technical information described in this document, including but not limited to, the product data, drawings, charts, programs, algorithms, and application examples.
3. No license, express, implied or otherwise, is granted hereby under any patents, copyrights or other intellectual property rights of Renesas Electronics or others.
4. You shall not alter, modify, copy, or reverse engineer any Renesas Electronics product, whether in whole or in part. Renesas Electronics disclaims any and all liability for any losses or damages incurred by you or third parties arising from such alteration, modification, copying or reverse engineering.
5. Renesas Electronics products are classified according to the following two quality grades: "Standard" and "High Quality". The intended applications for each Renesas Electronics product depends on the product's quality grade, as indicated below.
  - "Standard": Computers; office equipment; communications equipment; test and measurement equipment; audio and visual equipment; home electronic appliances; machine tools; personal electronic equipment; industrial robots; etc.
  - "High Quality": Transportation equipment (automobiles, trains, ships, etc.); traffic control (traffic lights); large-scale communication equipment; key financial terminal systems; safety control equipment; etc.Unless expressly designated as a high reliability product or a product for harsh environments in a Renesas Electronics data sheet or other Renesas Electronics document, Renesas Electronics products are not intended or authorized for use in products or systems that may pose a direct threat to human life or bodily injury (artificial life support devices or systems; surgical implantations; etc.), or may cause serious property damage (space system; undersea repeaters; nuclear power control systems; aircraft control systems; key plant systems; military equipment; etc.). Renesas Electronics disclaims any and all liability for any damages or losses incurred by you or any third parties arising from the use of any Renesas Electronics product that is inconsistent with any Renesas Electronics data sheet, user's manual or other Renesas Electronics document.
6. When using Renesas Electronics products, refer to the latest product information (data sheets, user's manuals, application notes, "General Notes for Handling and Using Semiconductor Devices" in the reliability handbook, etc.), and ensure that usage conditions are within the ranges specified by Renesas Electronics with respect to maximum ratings, operating power supply voltage range, heat dissipation characteristics, installation, etc. Renesas Electronics disclaims any and all liability for any malfunctions, failure or accident arising out of the use of Renesas Electronics products outside of such specified ranges.
7. Although Renesas Electronics endeavors to improve the quality and reliability of Renesas Electronics products, semiconductor products have specific characteristics, such as the occurrence of failure at a certain rate and malfunctions under certain use conditions. Unless designated as a high reliability product or a product for harsh environments in a Renesas Electronics data sheet or other Renesas Electronics document, Renesas Electronics products are not subject to radiation resistance design. You are responsible for implementing safety measures to guard against the possibility of bodily injury, injury or damage caused by fire, and/or danger to the public in the event of a failure or malfunction of Renesas Electronics products, such as safety design for hardware and software, including but not limited to redundancy, fire control and malfunction prevention, appropriate treatment for aging degradation or any other appropriate measures. Because the evaluation of microcomputer software alone is very difficult and impractical, you are responsible for evaluating the safety of the final products or systems manufactured by you.
8. Please contact a Renesas Electronics sales office for details as to environmental matters such as the environmental compatibility of each Renesas Electronics product. You are responsible for carefully and sufficiently investigating applicable laws and regulations that regulate the inclusion or use of controlled substances, including without limitation, the EU RoHS Directive, and using Renesas Electronics products in compliance with all these applicable laws and regulations. Renesas Electronics disclaims any and all liability for damages or losses occurring as a result of your noncompliance with applicable laws and regulations.
9. Renesas Electronics products and technologies shall not be used for or incorporated into any products or systems whose manufacture, use, or sale is prohibited under any applicable domestic or foreign laws or regulations. You shall comply with any applicable export control laws and regulations promulgated and administered by the governments of any countries asserting jurisdiction over the parties or transactions.
10. It is the responsibility of the buyer or distributor of Renesas Electronics products, or any other party who distributes, disposes of, or otherwise sells or transfers the product to a third party, to notify such third party in advance of the contents and conditions set forth in this document.
11. This document shall not be reprinted, reproduced or duplicated in any form, in whole or in part, without prior written consent of Renesas Electronics.
12. Please contact a Renesas Electronics sales office if you have any questions regarding the information contained in this document or Renesas Electronics products.

(Note1) "Renesas Electronics" as used in this document means Renesas Electronics Corporation and also includes its directly or indirectly controlled subsidiaries.

(Note2) "Renesas Electronics product(s)" means any product developed or manufactured by or for Renesas Electronics.

(Rev.4.0-1 November 2017)

## Corporate Headquarters

TOYOSU FORESIA, 3-2-24 Toyosu,  
Koto-ku, Tokyo 135-0061, Japan  
[www.renesas.com](http://www.renesas.com)

## Trademarks

Renesas and the Renesas logo are trademarks of Renesas Electronics Corporation. All trademarks and registered trademarks are the property of their respective owners.

## Contact information

For further information on a product, technology, the most up-to-date version of a document, or your nearest sales office, please visit:  
[www.renesas.com/contact/](http://www.renesas.com/contact/).

# General Precautions in the Handling of Microprocessing Unit and Microcontroller Unit Products

The following usage notes are applicable to all Microprocessing unit and Microcontroller unit products from Renesas. For detailed usage notes on the products covered by this document, refer to the relevant sections of the document as well as any technical updates that have been issued for the products.

## 1. Precaution against Electrostatic Discharge (ESD)

A strong electrical field, when exposed to a CMOS device, can cause destruction of the gate oxide and ultimately degrade the device operation. Steps must be taken to stop the generation of static electricity as much as possible, and quickly dissipate it when it occurs. Environmental control must be adequate. When it is dry, a humidifier should be used. This is recommended to avoid using insulators that can easily build up static electricity. Semiconductor devices must be stored and transported in an anti-static container, static shielding bag or conductive material. All test and measurement tools including work benches and floors must be grounded. The operator must also be grounded using a wrist strap. Semiconductor devices must not be touched with bare hands. Similar precautions must be taken for printed circuit boards with mounted semiconductor devices.

## 2. Processing at power-on

The state of the product is undefined at the time when power is supplied. The states of internal circuits in the LSI are indeterminate and the states of register settings and pins are undefined at the time when power is supplied. In a finished product where the reset signal is applied to the external reset pin, the states of pins are not guaranteed from the time when power is supplied until the reset process is completed. In a similar way, the states of pins in a product that is reset by an on-chip power-on reset function are not guaranteed from the time when power is supplied until the power reaches the level at which resetting is specified.

## 3. Input of signal during power-off state

Do not input signals or an I/O pull-up power supply while the device is powered off. The current injection that results from input of such a signal or I/O pull-up power supply may cause malfunction and the abnormal current that passes in the device at this time may cause degradation of internal elements. Follow the guideline for input signal during power-off state as described in your product documentation.

## 4. Handling of unused pins

Handle unused pins in accordance with the directions given under handling of unused pins in the manual. The input pins of CMOS products are generally in the high-impedance state. In operation with an unused pin in the open-circuit state, extra electromagnetic noise is induced in the vicinity of the LSI, an associated shoot-through current flows internally, and malfunctions occur due to the false recognition of the pin state as an input signal become possible.

## 5. Clock signals

After applying a reset, only release the reset line after the operating clock signal becomes stable. When switching the clock signal during program execution, wait until the target clock signal is stabilized. When the clock signal is generated with an external resonator or from an external oscillator during a reset, ensure that the reset line is only released after full stabilization of the clock signal. Additionally, when switching to a clock signal produced with an external resonator or by an external oscillator while program execution is in progress, wait until the target clock signal is stable.

## 6. Voltage application waveform at input pin

Waveform distortion due to input noise or a reflected wave may cause malfunction. If the input of the CMOS device stays in the area between  $V_{IL}$  (Max.) and  $V_{IH}$  (Min.) due to noise, for example, the device may malfunction. Take care to prevent chattering noise from entering the device when the input level is fixed, and also in the transition period when the input level passes through the area between  $V_{IL}$  (Max.) and  $V_{IH}$  (Min.).

## 7. Prohibition of access to reserved addresses

Access to reserved addresses is prohibited. The reserved addresses are provided for possible future expansion of functions. Do not access these addresses as the correct operation of the LSI is not guaranteed.

## 8. Differences between products

Before changing from one product to another, for example to a product with a different part number, confirm that the change will not lead to problems. The characteristics of a microprocessing unit or microcontroller unit products in the same group but having a different part number might differ in terms of internal memory capacity, layout pattern, and other factors, which can affect the ranges of electrical characteristics, such as characteristic values, operating margins, immunity to noise, and amount of radiated noise. When changing to a product with a different part number, implement a system-evaluation test for the given product.

## Renesas RA Family

**MCK-RA6T2 User's Manual**
**Contents**

1. Overview .....	4
1.1 Presupposition and precautions of this document .....	4
2. Product Contents .....	5
3. Product Order Information .....	5
4. Hardware Configuration and Default Setting .....	6
4.1 Hardware configuration .....	6
4.2 Block diagram .....	10
4.3 Board Layout .....	11
4.4 Standoffs and Screws .....	12
4.5 Jumper pin setting .....	13
4.5.1 Inverter Board .....	13
4.5.2 CPU Board .....	14
4.5.3 Communication Board .....	16
4.6 Hardware Setup .....	17
4.6.1 Board Connection .....	17
4.6.2 Power Supply .....	18
5. Inverter Board Specification .....	20
5.1 Functions .....	20
5.1.1 Inverter control circuit block .....	20
5.1.2 Current detection circuit .....	21
5.1.3 Overcurrent detection circuit .....	22
5.1.4 Output voltage detection circuit .....	23
5.1.5 Voltage generation circuit .....	23
5.1.6 LED .....	24
5.1.7 Toggle switch and push switch .....	24
5.1.8 Variable resistor .....	24
5.2 Pin assignment .....	25
5.2.1 CPU board connector .....	25
5.2.2 Hall sensor signal input .....	27
5.2.3 Encoder/Inductive position sensor signal input .....	27
6. CPU Board Specification .....	28
6.1 Functions .....	28
6.1.1 Power supply .....	28

6.1.2	Onboard debugger .....	28
6.1.3	Inverter board connector .....	29
6.1.4	Serial communication .....	31
6.1.5	Reset circuit.....	31
6.1.6	LED.....	32
6.1.7	CAN Communication.....	32
6.1.8	SPI communication .....	32
6.2	RA6T2 pin function list .....	33
7.	Communication Board Specification .....	36
7.1	Functions .....	36
7.1.1	Power supply .....	36
7.1.2	USB communication.....	36
7.1.3	Serial communication .....	36
8.	Design and Manufacture Information .....	37
9.	Website and Support .....	37

## Figure of contents

Figure 2-1	Product contents .....	5
Figure 4-1	MCK-RA6T2 block diagram .....	10
Figure 4-2	Inveter Board.....	11
Figure 4-3	CPU Board .....	11
Figure 4-4	Communication board .....	12
Figure 4-5	Standoffs and Screws assembly .....	12
Figure 4-6	Default jumper pin setting .....	13
Figure 4-7	Default jumper pin setting of CPU board .....	15
Figure 4-8	Default jumper pin setting of communication board.....	16
Figure 4-9	Board connection .....	17
Figure 4-10	Power supply from DC jack.....	18
Figure 4-11	Power supply from terminal block .....	18
Figure 4-12	Power supply from USB connector .....	19
Figure 5-1	Illustration of inverter control circuit block .....	20
Figure 5-2	Current detection circuit .....	21
Figure 5-3	Overcurrent detection circuit .....	22
Figure 5-4	Output voltage detection circuit.....	23
Figure 6-1	Connection for CPU board and inverter board.....	31

**Table of contents**

Table 4-1 MCK-RA6T2 specification (1/4).....	6
Table 4-2 MCK-RA6T2 specification (2/4).....	7
Table 4-3 MCK-RA6T2 specification (3/4).....	8
Table 4-4 MCK-RA6T2 specification (4/4).....	9
Table 4-5 Jumper pin setting of inverter board.....	13
Table 4-6 Jumper pin setting of CPU board .....	14
Table 4-7 Jumper pin setting of communication board .....	16
Table 4-8 Power supply and driving voltage generation .....	19
Table 5-1 Voltage generation .....	23
Table 5-2 LED.....	24
Table 5-3 Toggle switch and push switch.....	24
Table 5-4 Variable resistance specification .....	24
Table 5-5 CPU board connector (CN3) .....	25
Table 5-6 CPU board connector (CN4) .....	26
Table 5-7 Connector for hall sensor signal input (CN6) pin assignment.....	27
Table 5-8 Pins for encoder/inductive position sensor signal input (CN7) pin assignment .....	27
Table 6-1 1st Inverter board connector (CN4) pin assignment .....	29
Table 6-2 1st Inverter board connector (CN5) pin assignment .....	29
Table 6-3 2nd Inverter board connector (CN7) pin assignment .....	30
Table 6-4 2nd Inverter board connector (CN6) pin assignment .....	30
Table 6-5 SCI connector (CN10) pin assignment.....	31
Table 6-6 LED pin assignment .....	32
Table 6-7 CAN communication pin assignment (CN8).....	32
Table 6-8 SPI communication pin assignment (CN9) .....	32
Table 6-9 RA6T2 pin function list .....	33
Table 7-1 SCI connector (CN5) pin assignment.....	36
Table 7-2 SCI connector (CN4) pin assignment.....	36

# 1. Overview

MCK-RA6T2 is a motor control evaluation kit. By using this product, motor control with RA6T2 can be performed easily.

MCK-RA6T2 has characteristics shown below.

- (1) Supports Brushless DC motor.
- (2) Supports 1-/2-/3-shunt current detection.
- (3) Supports Motor Control Development Support Tool.
- (4) Provides overcurrent protection function using overcurrent detection circuit.

## 1.1 Presupposition and precautions of this document

1. Experience of using tools: This document assumes that the user has used terminal emulation program of Integrated Development Environment (IDE) such as e2 studio before.
2. Knowledge about the development subject: This document assumes that the user has a basic knowledge to modify the sample project regarding MCU and embedded system.
3. Before using this product, wear an antistatic wrist strap. If you touch this product with static charge on your body, a device failure may occur, or operation may become unstable
4. All screen shots provided in this document is for reference. Actual screen displays may differ depending on the software and development tool version which you use.

## 2. Product Contents

This kit consists of the following parts.

1. Inverter Board (RTK0EM0000B12020BJ) x1
2. CPU Board (RTK0EMA270C00000BJ) x1
3. Communication Board (RTK0EMXC90Z00000BJ) x1
4. Brushless DC Motor (R42BLD30L3) x1
5. Communication Cable x1
6. USB Cable x2
7. Screw x12
8. Standoff x12

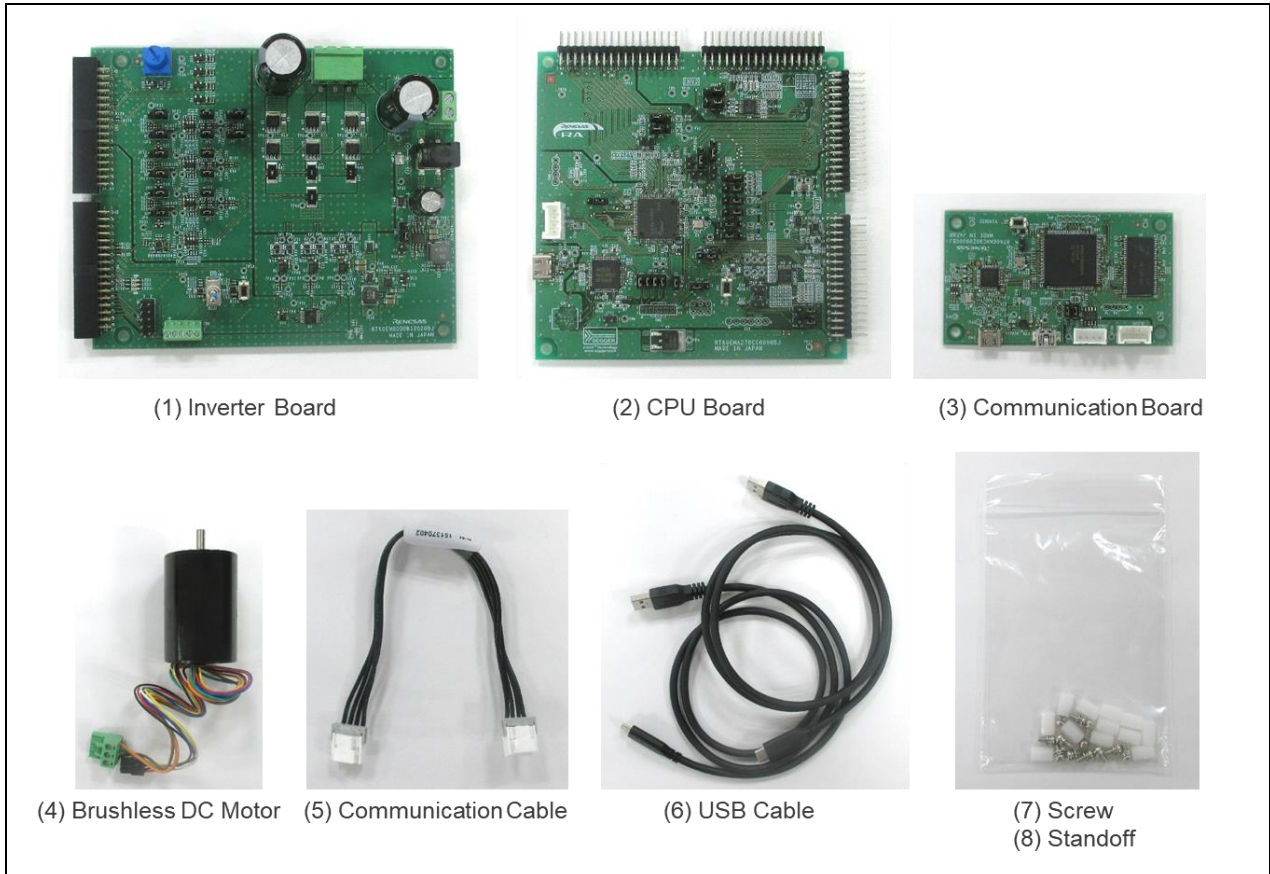

Figure 2-1 Product contents

## 3. Product Order Information

Product number to order MCK-RA6T2 : RTK0EMA270S00020BJ



## 4. Hardware Configuration and Default Setting

### 4.1 Hardware configuration

MCK-RA6T2 consists of the inverter board, the CPU board and the communication board. Specifications as a kit and for the relevant boards are listed below.

**Table 4-1 MCK-RA6T2 specification (1/4)**



Item	Specification	
Kit product name	MCK-RA6T2	
Kit product No.	RTK0EMA270S00020BJ	
Kit configuration	Inverter Board	RTK0EM0000B12020BJ
	CPU Board	RTK0EMA270C00000BJ
	Communication Board	RTK0EMXC90Z00000BJ
	Brushless DC Motor	R42BLD30L3 (MOONS') Rated voltage : 36[V] Rated current : 1.67[A]
Isolation	Inverter board - CPU board : Non-isolated Communication board - CPU board : Isolated	
External view	 <p style="text-align: center;">Note: The actual product may differ from this photo.</p>	
Board size	Inverter board : 133 mm (W) x 109 mm (L) CPU board : 109 mm (W) x 109 mm (L) Communication board : 89 mm (W) x 52 mm (L)	
Operating temperature	Room temperature	
Operating humidity	No condensation allowed	
EMC Directive	Europe : EN61326-1 : 2013 Class A	

Table 4-2 MCK-RA6T2 specification (2/4)

Item	Specification
Product name	Inverter board
Board part No.	RTK0EM0000B12020BJ
External view	 <p>Note: The actual product may differ from this photo.</p>
Power supply	2 ways <ul style="list-style-type: none"> <li>From DC jack or Power supply connector (DC 12~48V) *1</li> <li>From CPU board (DC 5V)</li> </ul>
Rated output current	AC 10 A (RMS value) *2
Switching frequency	20 kHz (typical)
Current detection method	1- / 2- / 3-shunt detection
Shunt resistor	10 mohm
PWM logic	Lower arm, Upper arm : Positive logic
DC bus voltage detection (bus voltage detection)	Detection by resistance division (0 V ~ 48 V)
3-phase output voltage detection	Detection by resistance division (0 V ~ 48 V)
3-phase output current detection	With shunt resistor (-16.5 A ~ +16.5 A)
Overcurrent detection function	21.4 A
Supporting sensor	HALL sensor, Encoder
Connector	<ul style="list-style-type: none"> <li>CPU card connector</li> <li>Motor connector</li> <li>Power input connector</li> <li>HALL sensor connector</li> <li>Encoder/Inductive position sensor connector</li> </ul>
Switch	<ul style="list-style-type: none"> <li>Toggle switch x1</li> <li>Push switch x1</li> </ul>
LED	<ul style="list-style-type: none"> <li>LED x3</li> <li>Power LED</li> </ul>

\*1 The polarity of the DC jack (J1) is center positive. The compatible plug has an inner diameter of 2.1 mm and an outer diameter of 5.5 mm.

\*2 It is strongly recommended to attach a heat sink to the MOSFET when using over 5A.

Table 4-3 MCK-RA6T2 specification (3/4)

item		Specification
Product name		CPU Board
Board part No.		RTK0EMA270C00000BJ
Compatible inverter board		RTK0EM0000B12020BJ
External view		 <p>Note: The actual product may differ from this photo.</p>
Mounted MCU	Product group	RA6T2 group
	Product No.	R7FA6T2BD3CFP
	CPU maximum operating frequency	240MHz
	Bit count	32 bit
	Package / Pin number	LFQFP / 100 pin
	RAM	64K byte
MCU input clock		10MHz (Generate with external crystal oscillator)
Power supply		DC 5V Select one way automatically from the below <ul style="list-style-type: none"> <li>• Power is supplied from compatible inverter board</li> <li>• Power is supplied from USB connector</li> </ul>
Debugger		J-Link-OB (Onboard debugger circuit)
Connector		<ul style="list-style-type: none"> <li>• Inverter board connector (2 sets)</li> <li>• USB connector for J-Link OB</li> <li>• SCI connector for Renesas Motor Workbench communication</li> <li>• Through hole for CAN communication</li> <li>• Through hole for SPI communication</li> <li>• 20 pin through hole for Arm debugger</li> </ul>
Switch		MCU reset switch
LED		User-controllable LED x6, Power LED x1

**Table 4-4 MCK-RA6T2 specification (4/4)**

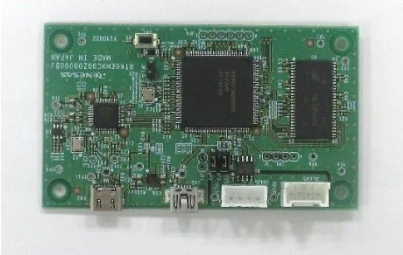
item		Specification
Product name		Communication Board
Board part No.		RTK0EMXC90Z00000BJ
External view		 <p>Note: The actual product may differ from this photo.</p>
Mounted MCU	Product group	RX72N group
	Product No.	R5F572NNDDFB
	CPU maximum operating frequency	240MHz
	Bit count	32 bit
	Package / Pin number	LFQFP / 144 pin
	RAM	1M byte
MCU input clock		20MHz (Generate with external crystal oscillator)
Power supply		DC 5V <ul style="list-style-type: none"> <li>Power is supplied from USB connector</li> </ul>
Connector		<ul style="list-style-type: none"> <li>USB Type-C connector for PC</li> <li>SCI connector for CPU board</li> <li>USB miniB connector (not available for users)</li> </ul>
Isolation		<ul style="list-style-type: none"> <li>Between SCI connector and MCU</li> </ul>
Switch		MCU external reset switch

### 4.2 Block diagram

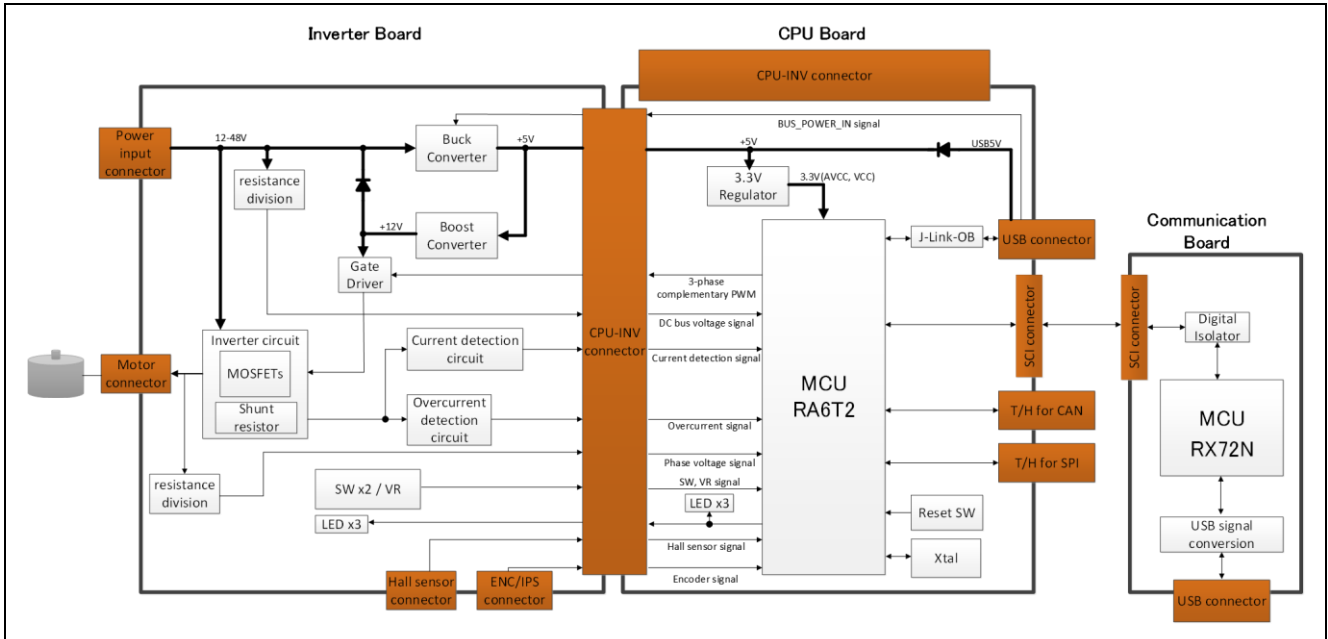

Figure 4-1 MCK-RA6T2 block diagram



4.3 Board Layout

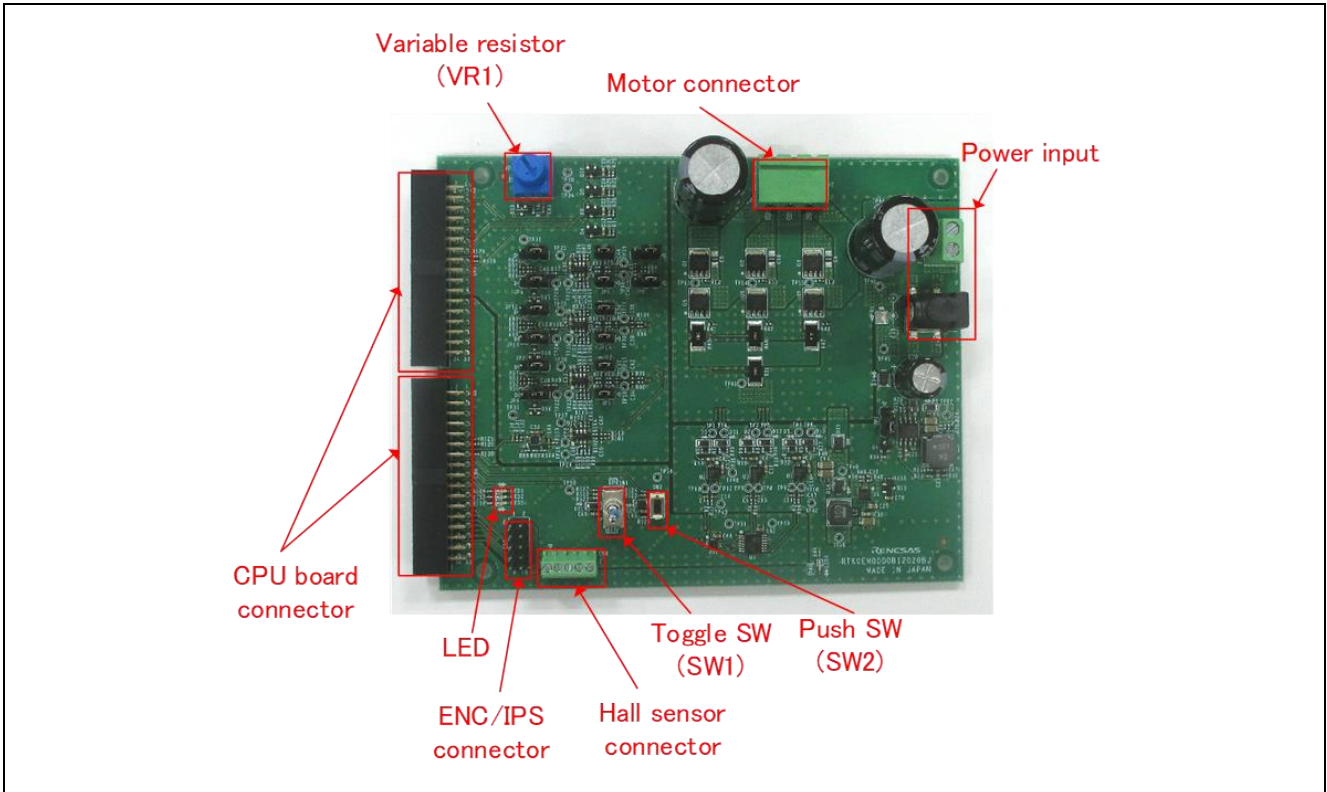

Figure 4-2 Inverter Board

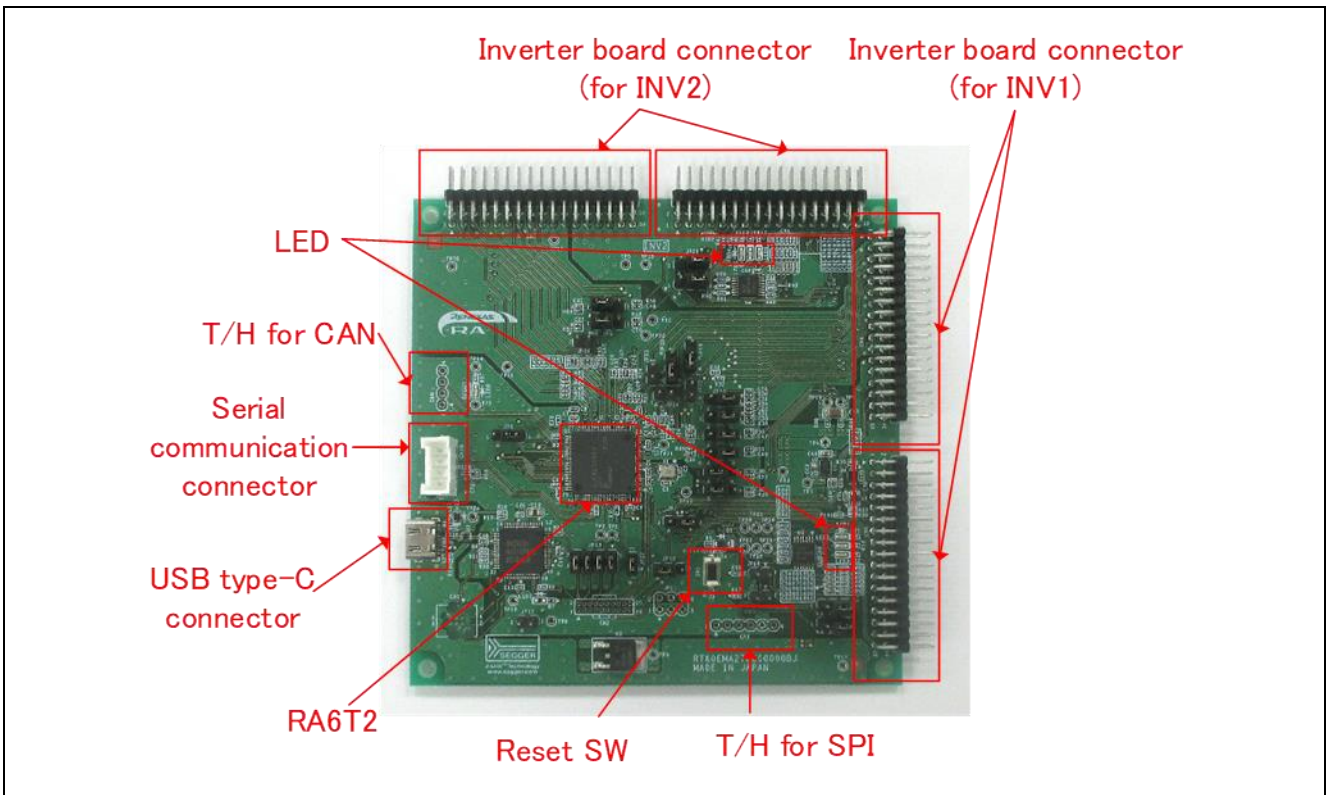

Figure 4-3 CPU Board

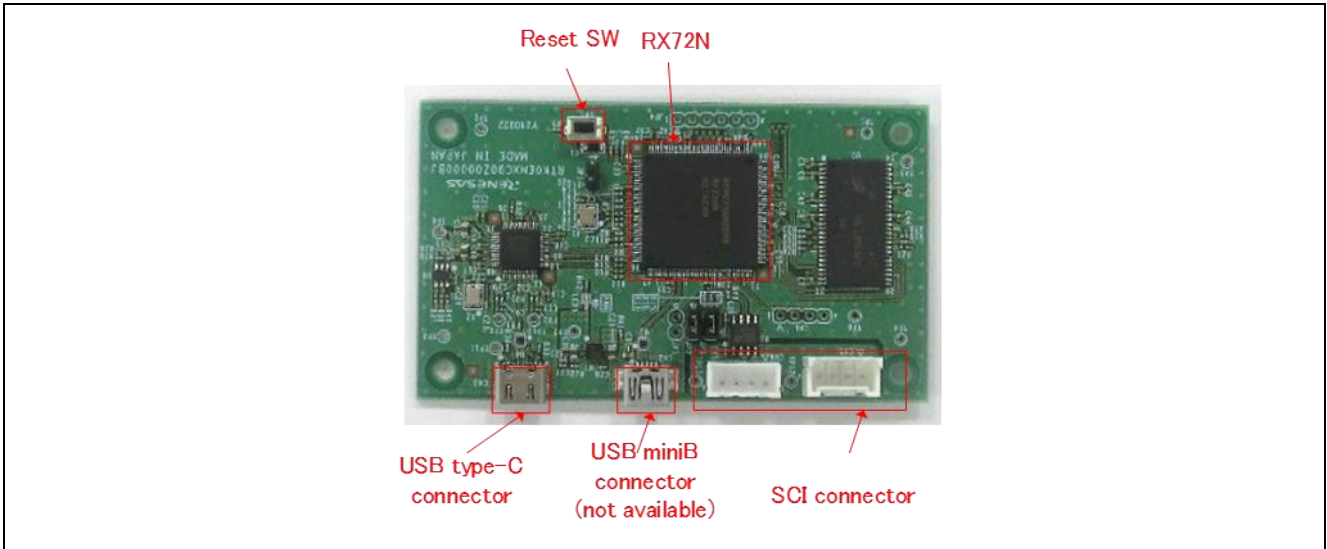

Figure 4-4 Communication board

### 4.4 Standoffs and Screws

Before using this product, assemble the included standoffs and screws as shown below.

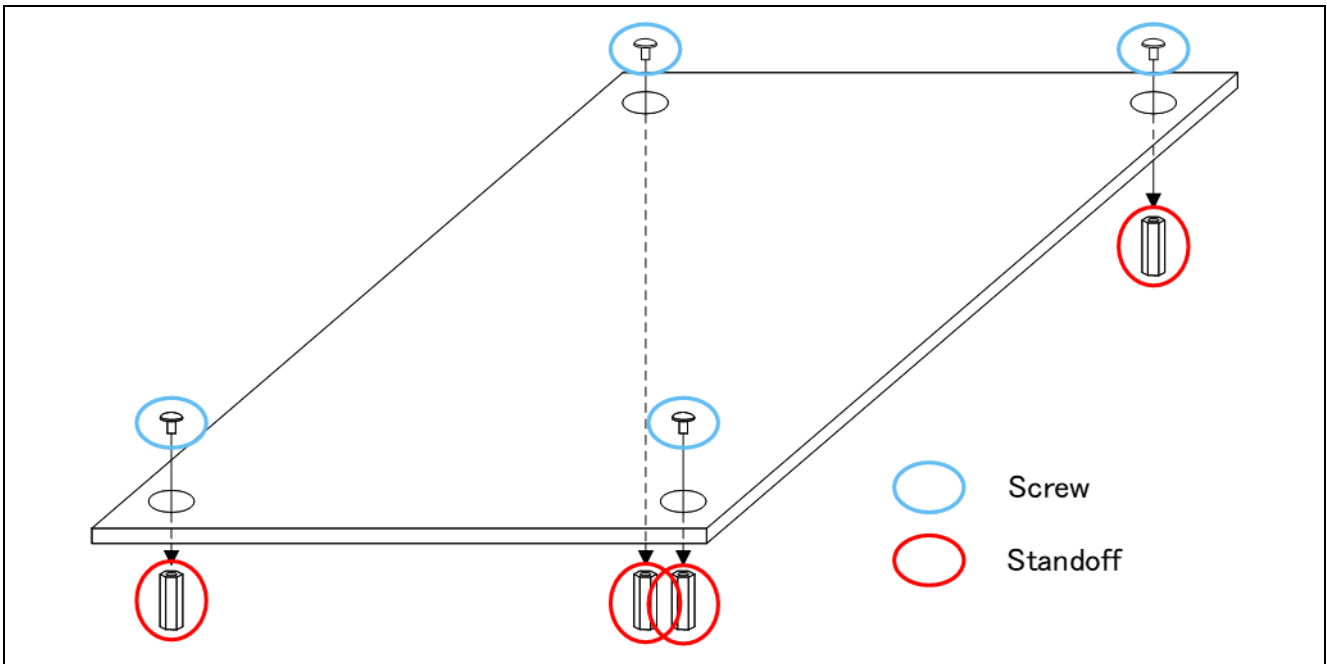

Figure 4-5 Standoffs and Screws assembly

### 4.5 Jumper pin setting

#### 4.5.1 Inverter Board

Default settings and functions of the jumper pins (JP1~JP15) are as follows.

**Table 4-5 Jumper pin setting of inverter board**

Jumper pin	Default setting	Function
JP1	2-3pin short	1-2pin short : Disable 5V regulator 2-3pin short : Enable 5V regulator
JP2, JP3, JP4, JP6, JP12, JP13	2-3pin short	1-2pin short : Disable current detection amplifiers 2-3pin short : Enable current detection amplifiers
JP5, JP7, JP9, JP10, JP14, JP15	1-2pin short	1-2pin short : Current detection amplifier gain = 20 1-2pin open : Current detection amplifier gain = 10
JP8, JP11	1-2pin short	1-2pin short : 2-/3-shunt current detection 2-3pin short : 1-shunt current detection

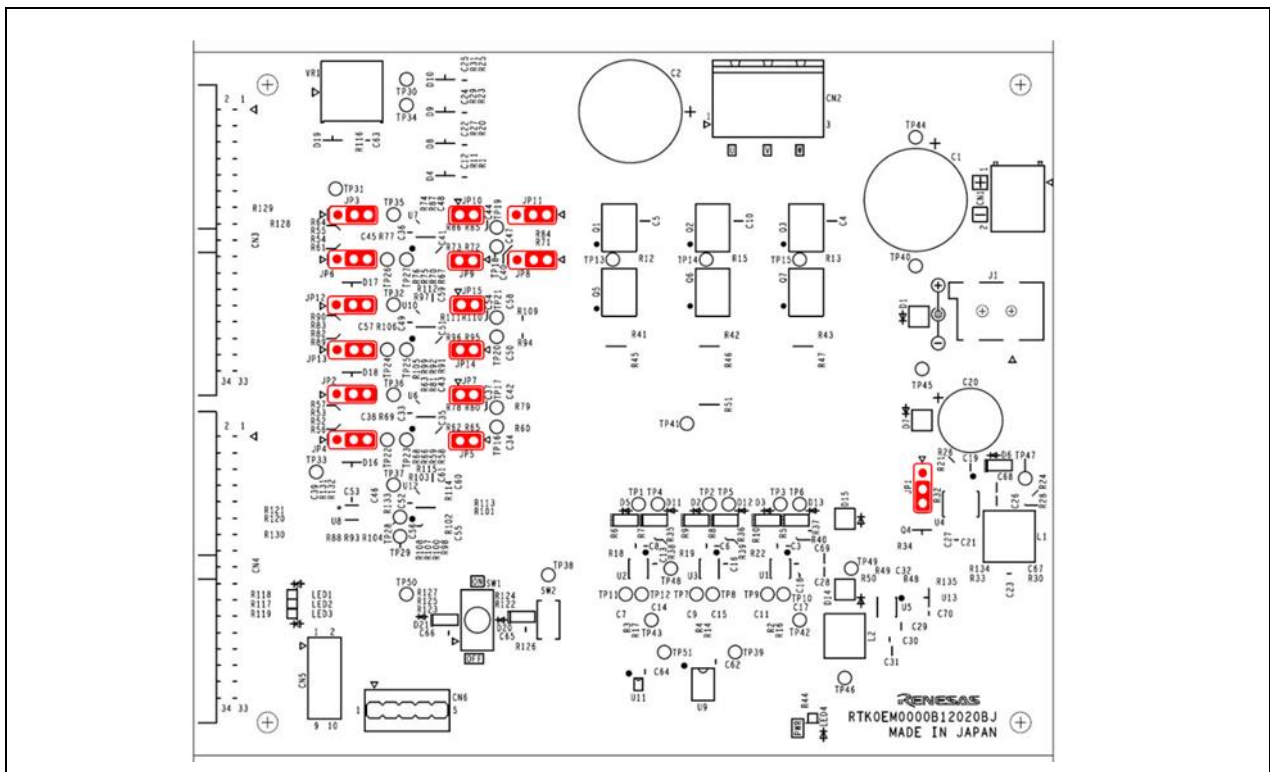

**Figure 4-6 Default jumper pin setting**



## 4.5.2 CPU Board

Default settings and functions of the jumper pins (JP1~JP25) are as follows.

**Table 4-6 Jumper pin setting of CPU board**

Jumper pin	Default setting	Function
JP1	2-3pin short	1-2pin short : INV1 IPS CSN_IRQN 2-3pin short : INV1 Encoder Z
JP2	2-3pin short	1-2pin short : INV2 PFC current detection (for HV INV) 2-3pin short : INV2 IPS A
JP3	2-3pin short	1-2pin short : INV2 AC input voltage detection (for HV INV) 2-3pin short : INV2 IPS A#/Encoder A#
JP4	1-2pin short	1-2pin short : INV1 HALL U 2-3pin short : INV1 IPS A
JP5	1-2pin short	1-2pin short : INV1 HALL V 2-3pin short : INV1 IPS A#/Encoder A#
JP6	1-2pin short	1-2pin short : INV2 V-phase voltage detection 2-3pin short : INV2 IPS B
JP7	2-3pin short	1-2pin short : INV1 PFC current detection (for HV INV) 2-3pin short : INV1 IPS B#
JP8	2-3pin short	1-2pin short : INV2 IPS CSN_IRQN 2-3pin short : INV2 Encoder Z
JP9	1-2pin short	1-2pin short : INV2 W-phase voltage detection 2-3pin short : INV2 IPS B#/Encoder B#
JP10	2-3pin short	1-2pin short : INV1 AC input voltage detection (for HV INV) 2-3pin short : INV1 IPS B#/Encoder B#
JP11	1-2pin open 3-4pin open 5-6pin open	
JP12	1-2pin open	1-2pin short : Disable J-Link OB 1-2pin open : Enable J-Link OB
JP13	1-2pin short 3-4pin short 5-6pin short 7-8pin short	
JP14	1-2pin short	1-2pin short : Enable RA6T2 2-3pin short : Disable RA6T2
JP15, JP16	1-2pin open	1-2pin short : Enable pull-up for I2C 1-2pin open : Disable pull-up for I2C
JP17	2-3pin short	1-2pin short : INV1 IPS A 2-3pin short : INV1 Encoder A
JP18	2-3pin short	1-2pin short : INV1 IPS B 2-3pin short : INV1 Encoder B
JP19	1-2pin short	1-2pin short : INV1 W-phase voltage detection 2-3pin short : INV1 W-phase current detection (PGAVSS)
JP20	1-2pin short	1-2pin short : INV1 V-phase voltage detection 2-3pin short : INV1 V-phase current detection (PGAVSS)
JP21	2-3pin short	1-2pin short : INV2 IPS A 2-3pin short : INV2 Encoder A
JP22	2-3pin short	1-2pin short : INV2 IPS B 2-3pin short : INV2 Encoder B
JP23, JP24, JP25	1-2pin open	1-2pin open : Enable LPF for current sensing 1-2pin short : Disable LPF for current sensing

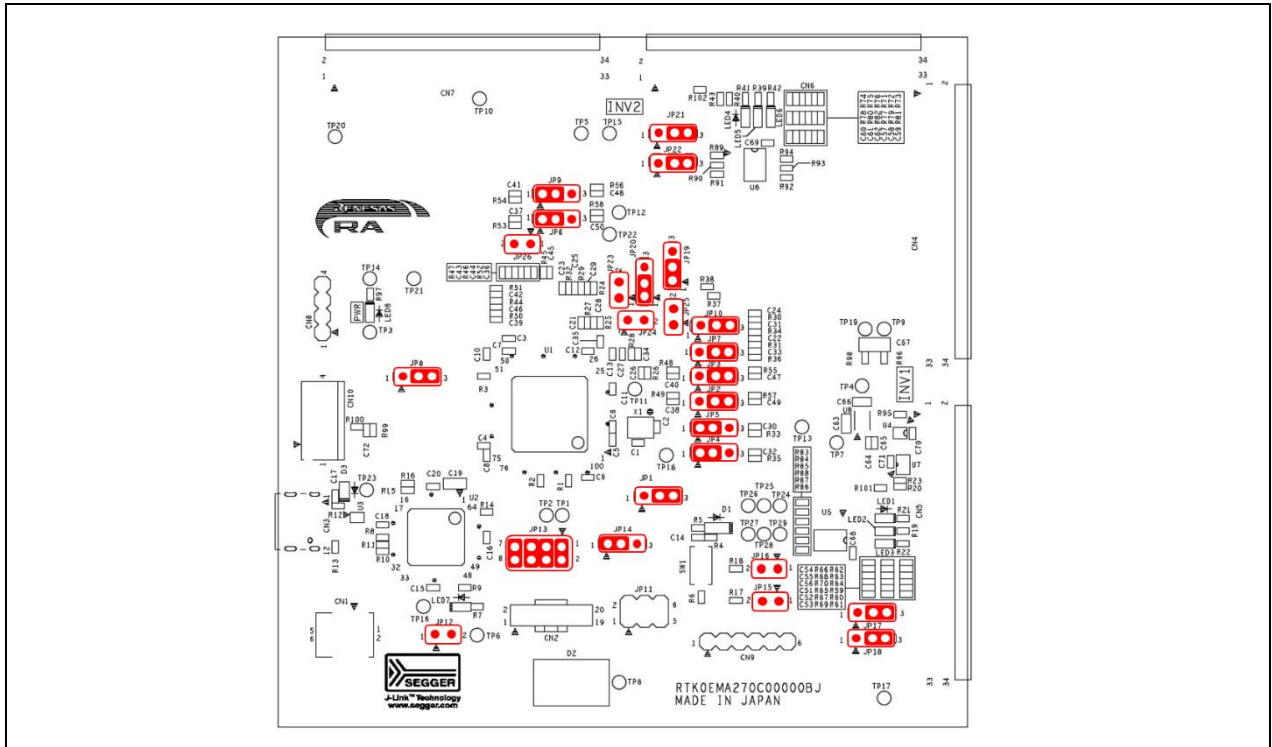

Figure 4-7 Default jumper pin setting of CPU board

4.5.3 Communication Board

Default settings and functions of the jumper pins (JP1~JP3) are as follows.

Table 4-7 Jumper pin setting of communication board

Jumper pin	Default setting	Function
JP1	1-2pin open	1-2pin short : Enable pull-up for MD port (Not available) 1-2pin open : Enable pull-up for MD port
JP2	1-2pin short	1-2pin short : Disable pull-up for GPIO(PC6) 1-2pin open : Enable pull-up for GPIO(PC6)
JP3	1-2pin short	1-2pin short : Disable pull-up for GPIO(PC5) 1-2pin open : Enable pull-up for GPIO(PC5)

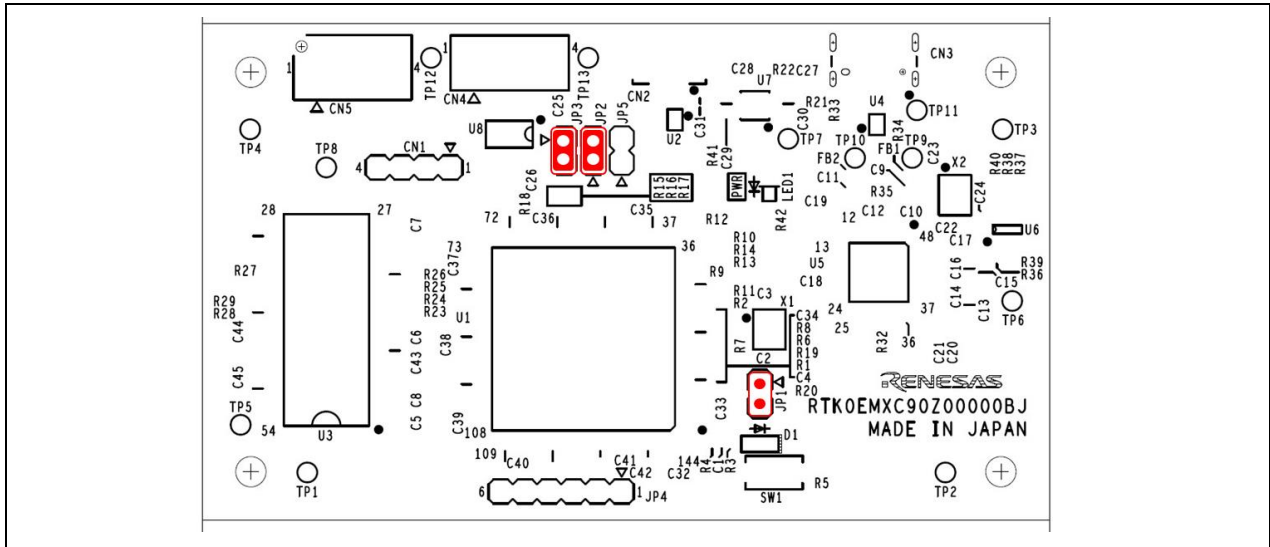

Figure 4-8 Default jumper pin setting of communication board

## 4.6 Hardware Setup

### 4.6.1 Board Connection

When using this product for motor control evaluation, connect the boards as shown in Figure 4-9. Note that the connector between the CPU board and the inverter board is a tight fit, so be careful not to bend the pins when connecting or disconnecting.

Please refer to 4.6.2 for the power supply method. In Figure 4-9, the power is supplied from the AC adapter. The RA6T2 CPU board supports a maximum of two-motor control and can be connected as shown in Fig. 6.1 shown later, if you prepare an additional inverter board and motor.

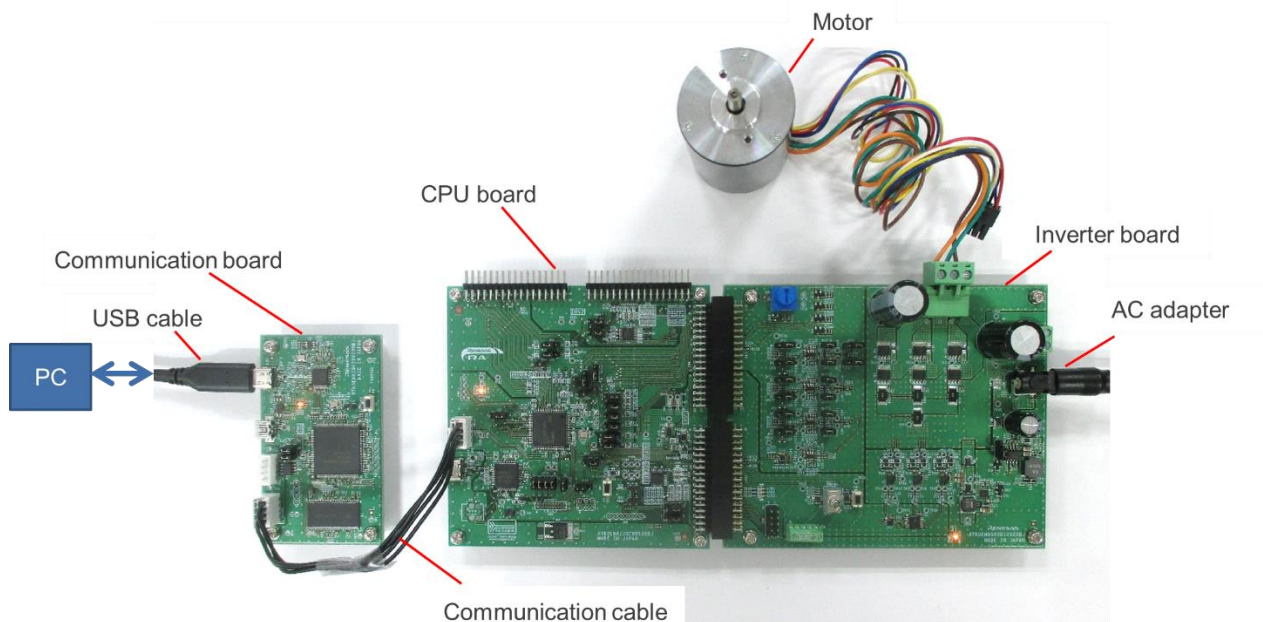

**Figure 4-9 Board connection**

### 4.6.2 Power Supply

There are three ways to supply power to the CPU board and inverter board, and the power supply for the communication board is independent of the CPU board and inverter board and is supplied at 5V from the USB connector.

#### (1) From DC jack

Use an AC adapter or something similar to supply power from the DC jack (J1) on the inverter board. The compatible plug has an outer diameter of 5.5 mm, an inner diameter of 2.1 mm, and a polarity of center positive. The input voltage range is 12 to 48V.



Figure 4-10 Power supply from DC jack

#### (2) From terminal block

Supply power from the terminal block (CN1) of the inverter board using a DC stabilized power supply or the like. The polarity should follow the silk indication (“+”, “-”) on the board. The input voltage range is 12 to 48V.

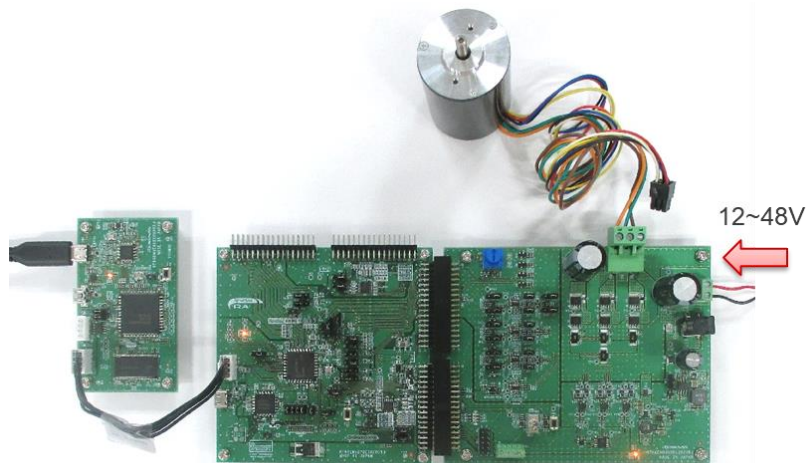
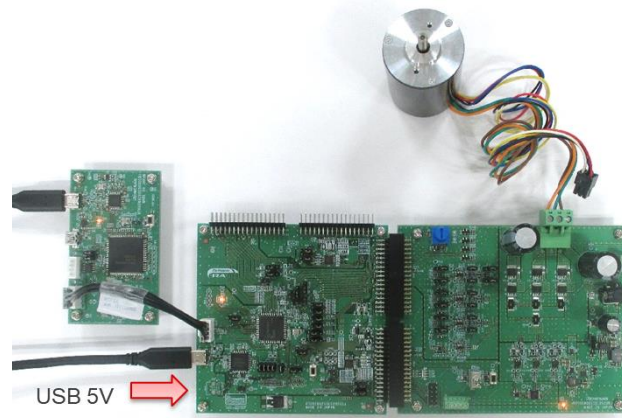

Figure 4-11 Power supply from terminal block

**(3) From USB connector**

5V power is supplied from the USB connector (Type-C) on the CPU board. Use a USB adapter capable of outputting 1A or more so that the motor can be driven sufficiently.



**Figure 4-12 Power supply from USB connector**

It is also possible to supply power from the USB connector on the CPU board and the DC jack or terminal block on the inverter board at the same time. In this case, the MCU drive voltage of 3.3V and the gate driver drive voltage are generated from the USB supply of 5V, while the motor drive voltage is supplied from the DC jack or terminal block. Please refer to Table 4-8 for the power supply conditions and each voltage generation.

**Table 4-8 Power supply and driving voltage generation**

			Case 1	Case 2	Case 3
Power supply condition	CPU board	USB 5V *1	✓	-	✓
	Inverter board	External power (12~48V) *2	-	✓	✓
Power source for	CPU board	I/O (VCC, 3.3V)	[A]	[B]	[A]
		BUS (5V)	[A]	[B]	[A]
	Inverter board	I/O (VCC, 3.3V)	[A]	[B]	[A]
		BUS (5V)	[A]	[B]	[A]
		Gate driver (11.4V)	[A]	[B]	[A]
		Motor drive (11.4V or 12~48V)	[A]	[B]	[B]

Power supply condition:

- ✓: supplied
- : not supplied

Driving voltage generation

- [A]: generated from USB 5V on CPU board
- [B]: generated from external power on inverter board

\*1 Motor drive current of 1 A or more may be required for each inverter board.

\*2 When connecting two inverter boards to the CPU board and also inputting an external power supply to INV2, it is necessary to supply an external power supply (which can be different from INV2) to INV1 as well, or to supply USB 5V to the CPU board.



## 5. Inverter Board Specification

This section describes inverter board specification.

### 5.1 Functions

#### 5.1.1 Inverter control circuit block

The inverter board has the inverter control circuit block which controls the motor with 6 POWER MOSFETs. POWER MOSFET is controlled with 6-phase timer output of MCU.

The inverter control circuit block outputs DC bus voltage, U, V and W phase voltage and shunt current to the connectors (CN3, CN4). By inputting these output voltages to A/D of MCU on the CPU card, analog values of the voltage and the shunt current of each phase can be measured. Refer to 5.1.2 and 5.1.4 for the current detection and the voltage detection, respectively. Also function to detect overcurrent from the input current is available. Refer to 5.1.3 for details.

An illustration of the inverter control circuit block is shown in Figure 5-1. In the actual circuit, some inputs on the A/D pins are via voltage dividers and offsets and so on. Refer to the circuit diagram for details.

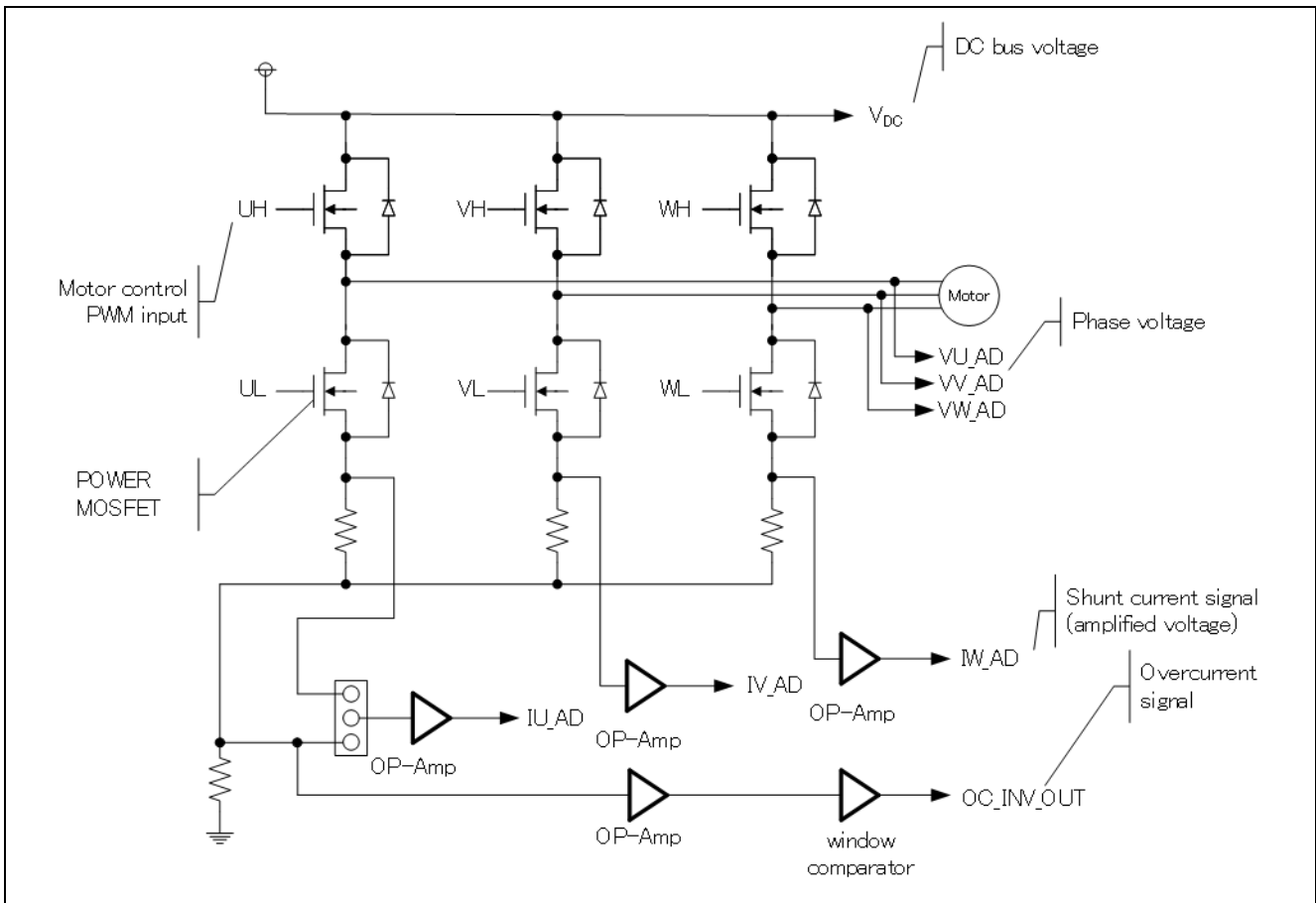

Figure 5-1 Illustration of inverter control circuit block

**5.1.2 Current detection circuit**

The inverter board has the current detection circuit to measure the current at the U, V and W phase. The current detection circuit uses shunt resistor at each phase. Voltage drop caused by the current flowing through the shunt resistor is amplified by the current detection amplifier to output. The default gain of the current detection amplifier is set to 20x, but the gain can be changed to 10x by setting JP5, JP7, JP9, JP10, JP14, and JP15 to open. The relationship between the current  $I_{in}$  flowing through the shunt resistor and the voltage  $V_{out}$  output from the current detection circuit is shown in equations (1) and (2). In addition, by switching JP8 and JP11 to 2-3 pin short circuit, one shunt current detection can be supported.

$$\text{Amplifier gain } 10x : V_{out}[V] = I_{in}[A] \times R_s[\Omega] \times 10 + AVCC/2 \quad (1)$$

$$\text{Amplifier gain } 20x : V_{out}[V] = I_{in}[A] \times R_s[\Omega] \times 20 + AVCC/2 \quad (2)$$

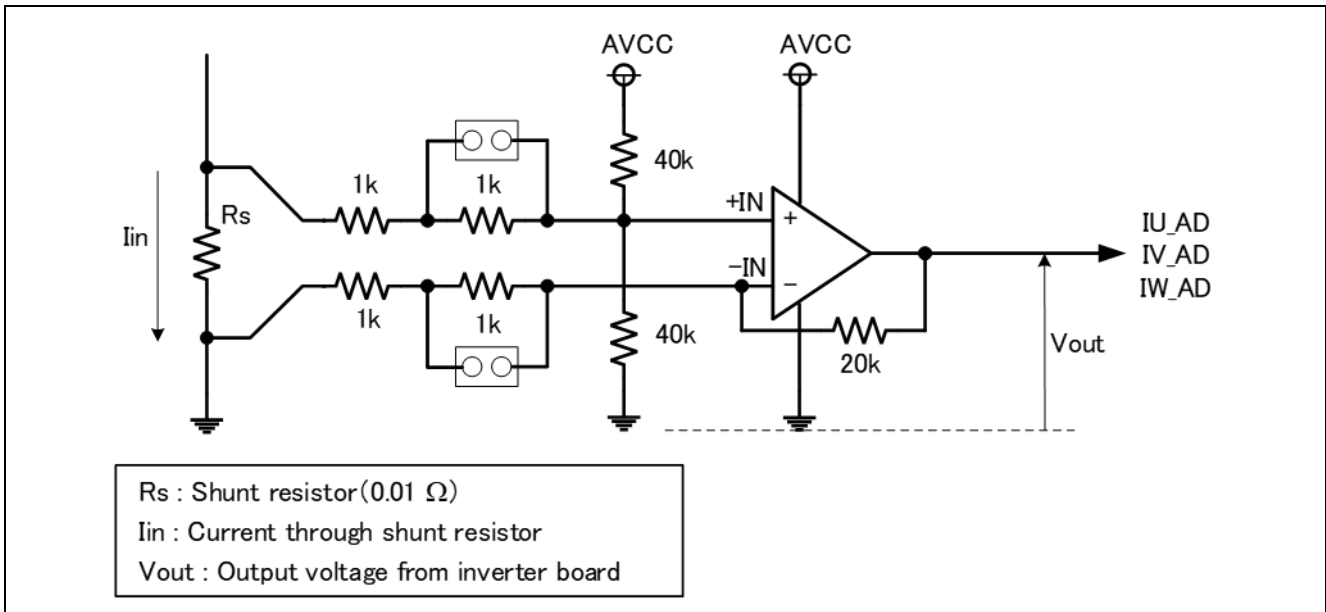

**Figure 5-2 Current detection circuit**



**5.1.3 Overcurrent detection circuit**

Detect the overcurrent from the input current, using the overcurrent detection circuit illustrated in Figure 5-3. If the current value is within the range of threshold, OC\_INV\_OUT is HIGH, and this changes to LOW if overcurrent is detected. Therefore, you can protect the board and motor by monitoring the over current detection signal and setting PWM signals for gate driver to LOW or Hi-Z if the over current detection signal changes to LOW.

The overcurrent detection circuit does not directly protect the board and motor. Protect them by performing appropriate processing with equipment such as microcontroller.

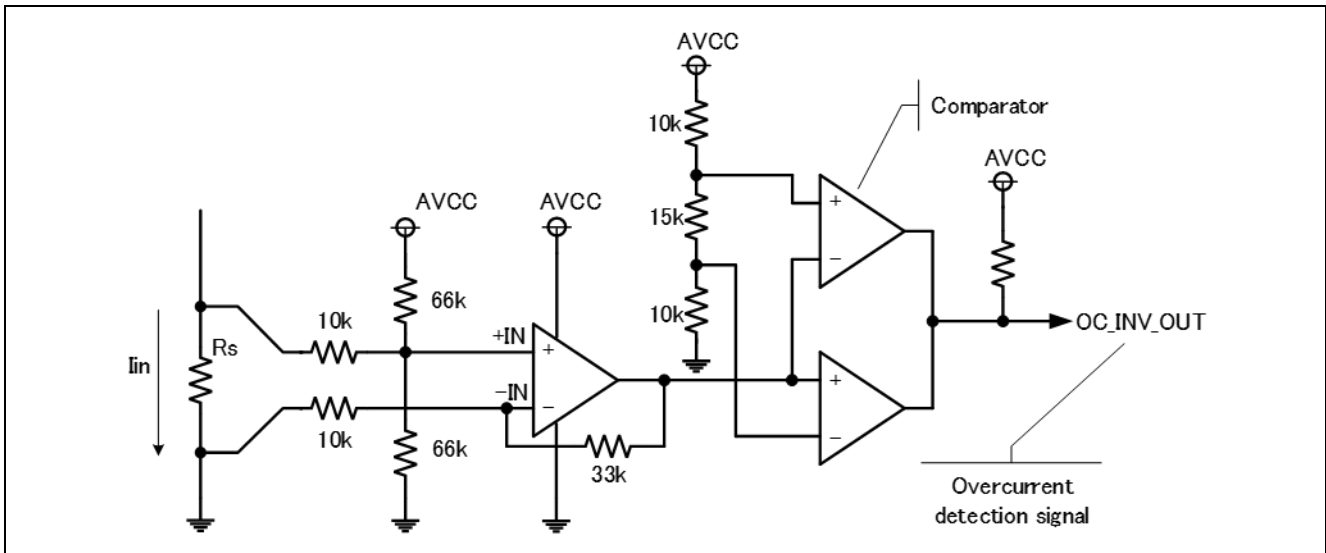
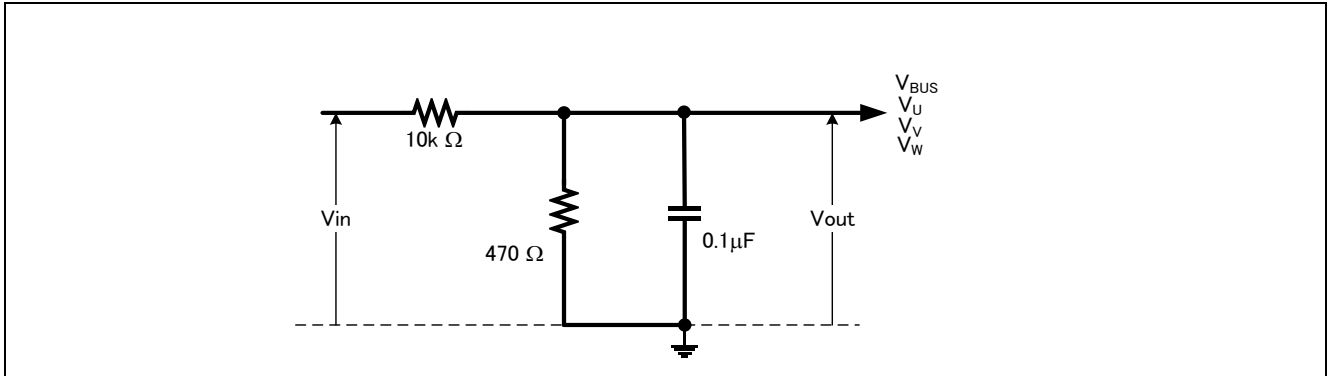

**Figure 5-3 Overcurrent detection circuit**

**5.1.4 Output voltage detection circuit**

The INV-BRD has the circuit that inputs bus voltage and three-phase output voltage (U, V and W phase) into the AD pin of the microcontroller through resistive voltage divider. Relation between the three-phase output voltage, the bus voltage and the detection voltage is described by the below equation (3).

$$V_{out}[V] = \frac{470}{10 \times 10^3 + 470} \times V_{in}[V] \quad (3)$$



**Figure 5-4 Output voltage detection circuit**

**5.1.5 Voltage generation circuit**

On the INV-BRD, the gate driver voltage ("+12V" in the schematic) is generated from the 5V power supply ("+5V" in the schematic) with the boost converter. If 5V is not supplied from the CPU board, the buck converter on the INV-BRD generates 5V from the voltage input (12 to 48V) from the DC jack or terminal block.

**Table 5-1 Voltage generation**

Item	Input voltage [V]	Output voltage (TYP.) [V]	Output current (Max) [A]
5V generation	12~48	5	0.6
Gate driver voltage generation	5	11.4	-

### 5.1.6 LED

The INV-BRD has three LEDs which the user can control. The LED ON/OFF is controlled by the pin state.

**Table 5-2 LED**

Connector pin		LED1	LED2	LED3
CN4-18	HIGH	OFF	-	-
	LOW	ON	-	-
CN4-19	HIGH	-	OFF	-
	LOW	-	ON	-
CN4-20	HIGH	-	-	OFF
	LOW	-	-	ON

### 5.1.7 Toggle switch and push switch

The INV-BRD has toggle switch (SW1) and push switch (SW2). The pin voltage is controlled by the state of them.

**Table 5-3 Toggle switch and push switch**

Connector pin		SW1	SW2
CN4-16	HIGH	OFF	-
	LOW	ON	-
CN4-17	HIGH	-	RELEASE
	LOW	-	PUSH

### 5.1.8 Variable resistor

The INV-BRD has a variable resistor (VR1). If turning the variable resistor clockwise, terminal voltage of the variable resistor (CN3-17) becomes low. If turning it counterclockwise, the voltage becomes high.

**Table 5-4 Variable resistance specification**

Item	Specification
Input voltage range	0~AVCC
Variable resistor range	0~10k $\Omega$

## 5.2 Pin assignment

### 5.2.1 CPU board connector

Table 5-5 CPU board connector (CN3)

Pin No.	Output direction	Signal
1	-	SPARE1
2	-	AGND
3	To CPU	DC bus voltage detection
4	-	AGND
5	To CPU	U-phase current detection
6	To CPU	U-phase current detection (PGAVSS)
7	To CPU	V-phase current detection
8	To CPU	V-phase current detection (PGAVSS)
9	To CPU	W-phase current detection
10	To CPU	W-phase current detection (PGAVSS)
11	To CPU	U-phase voltage detection
12	To CPU	V-phase voltage detection
13	To CPU	W-phase voltage detection
14	-	AGND
15	To CPU	VPFC_AD
16	To CPU	IPFC_AD
17	To CPU	VR1
18	-	AGND
19	-	AVCC
20	-	AVCC
21	-	AGND
22	-	AGND
23	-	VCC
24	-	VCC
25	-	DGND
26	-	DGND
27	To INV	PWM U-phase (Lower)
28	-	DGND
29	To INV	PWM U-phase (Upper)
30	-	DGND
31	To INV	PWM V-phase (Lower)
32	-	DGND
33	To INV	PWM V-phase (Upper)
34	-	DGND

Table 5-6 CPU board connector (CN4)

Pin No.	Output direction	Signal
1	To INV	PWM W-phase (Lower)
2	-	DGND
3	To INV	PWM W-phase (Upper)
4	-	DGND
5	-	SPARE2
6	-	SPARE3
7	-	SPARE4
8	-	SPARE5
9	To INV	Bus power signal from CPU board
10	To CPU	Inverter connected signal
11	To CPU	Save interlock signal
12	To CPU	Over current detection
13	To CPU	OC_PFC_OUT
14	To INV	PWM_IN
15	To INV	RELAY_IN
16	To CPU	SW1
17	To CPU	SW2
18	To INV	LED1
19	To INV	LED2
20	To INV	LED3
21	To CPU	HALL U
22	To CPU	HALL V
23	To CPU	HALL W
24	To CPU	IPS_SIO_SDA
25	To CPU	IPS_SCK_SCL
26	To CPU	IPS_CSN_IRQN/Encoder Z
27	To CPU	IPS_A/ Encoder A
28	To CPU	IPS_A#/ Encoder A#
29	To CPU	IPS_B/ Encoder B#
30	To CPU	IPS_B#/ Encoder B#
31	-	AGND
32	-	AGND
33	-	+5V
34	-	+5V

### 5.2.2 Hall sensor signal input

This product has connector for hall sensor signal input. Pin assignment of it is listed in Table 5-7.

**Table 5-7 Connector for hall sensor signal input (CN6) pin assignment**

Pin No.	Pin Function
1	DGND
2	+5V
3	HALL_W
4	HALL_V
5	HALL_U

### 5.2.3 Encoder/Inductive position sensor signal input

This product has pins for encoder/inductive position sensor signal input. Pin assignment for them is listed in Table 5-8

**Table 5-8 Pins for encoder/inductive position sensor signal input (CN7) pin assignment**

Pin No.	Pin function
1	VCC
2	+5V
3	CSN_IRQN/ENC_Z
4	SIO_SDA
5	SCK_SCL
6	IPS_A/ENC_A
7	IPS_A#/ENC_A#
8	IPS_B/ENC_B
9	IPS_B#/ENC_B#
10	DGND

## 6. CPU Board Specification

This section describes the specification of the CPU Board.

### 6.1 Functions

#### 6.1.1 Power supply

When not connected to the inverter board, power should be supplied from the USB connector. When connecting to the inverter board, power supply from the USB connector or from the inverter board will be automatically selected. USB power supply has priority.

#### 6.1.2 Onboard debugger

This product has the onboard debugger circuit, J-Link On-Board (hereinafter called "J-Link-OB"). You can write a program (firmware) of RA6T2 with it. When you write a program, connect the CPU board to PC with USB cable. J-Link-OB operates as debugger equivalent to J-Link. If connecting from Integrated Development Environment or flash programming tool (e.g. J-Flash Lite by SEGGER), set the type of debugger (tool) to "J-Link".

### 6.1.3 Inverter board connector

Two inverter boards can be connected to this board: the 1st inverter board is connected with CN4 and CN5, and the 2nd inverter board is connected with CN6 and CN7. The pin assignments of the connectors are shown in Table 6-1, Table 6-2, Table 6-3 and Table 6-4. Note that these tables show default connection setting for the ports with jumper switches.

**Table 6-1 1st Inverter board connector (CN4) pin assignment**

Pin No	Pin Function	RA6T2 Pin	Pin No	Pin Function	RA6T2 Pin
1	SPARE1	-	2	AGND	-(AVSS)
3	VPN	PA06/AN006	4	AGND	-(AVSS)
5	IU	PA04/AN004	6	PGAVSSU	PA05/PGAVSS2
7	IV	PA02/AN002	8	PGAVSSV	PA03/AN003
9	IW	PA00/AN000	10	PGAVSSW	PA01/AN001
11	VU	PA07/AN007	12	VV	PA03/AN003
13	VW	PA01/AN001	14	AGND	-(AVSS)
15	VAC	PB10/AN028	16	IPFC	PE15/AN027
17	VR	PB00/AN008	18	AGND	-(AVSS)
19	AVCC	-(AVCC)	20	AVCC	-(AVCC)
21	AGND	-(AVSS)	22	AGND	-(AVSS)
23	VCC	-(VCC)	24	VCC	-(VCC)
25	GND	-(VSS)	26	GND	-(VSS)
27	UN	PB05/GTIOC4B_B	28	GND	-(VSS)
29	UP	PB04/GTIOC4A_B	30	GND	-(VSS)
31	VN	PB07/GTIOC5B_B	32	GND	-(VSS)
33	VP	PB06/GTIOC5A_B	34	GND	-(VSS)

**Table 6-2 1st Inverter board connector (CN5) pin assignment**

Pin No	Pin Function	RA6T2 Pin	Pin No	Pin Function	RA6T2 Pin
1	WN	PB09/GTIOC6B_B	2	GND	-(VSS)
3	WP	PB08/GTIOC6A_B	4	GND	-(VSS)
5	SPARE2	-	6	SPARE3	-
7	SPARE4	-	8	SPARE5	-
9	BUS_POWER_IN	-	10	INV_CONNECTED	-
11	SAFE_LOCK	-	12	OC#	PC13/GTETRGD
13	PFCERROR	P001/IRQ2	14	PFCPWM	PB14/GTIOC1A
15	VRL	PE01	16	SW1	PD04
17	SW2	PD07	18	LED1	PD01
19	LED2	PD02	20	LED3	PD03
21	HALL_U	PC04/IRQ10_B	22	HALL_V	PC05/IRQ11_B
23	HALL_W	PB01/IRQ1_B	24	MISO0/SIO_SDA	PC11/MISOB_B
25	SCK0/SCK_SCL	PC10	26	CSN_IRQN/ENC_Z	PE00/GTETRGA
27	IPS_A ENC_A	PC04 PC13/GTIOC3A_D	28	IPS_A#/ENC_A#	PC05/IRQ11_B
29	IPS_B ENC_B	PE15 PC15/GTIOC3B_D	30	IPS_B#/ENC_B#	PB10/AN028
31	GND	-(VSS)	32	GND	-(VSS)
33	+5V	-	34	+5V	-



Table 6-3 2nd Inverter board connector (CN7) pin assignment

Pin No	Pin Function	RA6T2 Pin	Pin No	Pin Function	RA6T2 Pin
1	SPARE1	-	2	AGND	- (AVSS)
3	VPN	PE13/AN025	4	AGND	- (AVSS)
5	IU	PB02/AN018	6	PGAVSSU	P002/PGAVSS3
7	IV	PE08/AN020	8	PGAVSSV	-
9	IW	PE09/AN021	10	PGAVSSW	-
11	VU	PE10/AN022	12	VV	PE11/AN023
13	VW	PE12/AN024	14	AGND	- (AVSS)
15	VAC	PC03/AN015	16	IPFC	PC02/AN014
17	VR	PE14/AN026	18	AGND	- (AVSS)
19	AVCC	- (AVCC)	20	AVCC	- (AVCC)
21	AGND	- (AVSS)	22	AGND	- (AVSS)
23	VCC	- (VCC)	24	VCC	- (VCC)
25	GND	- (VSS)	26	GND	- (VSS)
27	UN	PC09/GTIOC7B_A	28	GND	- (VSS)
29	UP	PC08/GTIOC7A_A	30	GND	- (VSS)
31	VN	PA09/GTIOC8B_A	32	GND	- (VSS)
33	VP	PA08/GTIOC8A_A	34	GND	- (VSS)

Table 6-4 2nd Inverter board connector (CN6) pin assignment

Pin No	Pin Function	RA6T2 Pin	Pin No	Pin Function	RA6T2 Pin
1	WN	PA11/GTIOC9B_A	2	GND	- (VSS)
3	WP	PA10/GTIOC9A_A	4	GND	- (VSS)
5	SPARE2	-	6	SPARE3	-
7	SPARE4	-	8	SPARE5	-
9	BUS_POWER_IN	-	10	INV_CONNECTED	-
11	SAFE_LOCK	-	12	OC#	PA12/GTETRGB
13	PFCERROR	P000/IRQ0	14	PFCPWM	PB15/GTIOC1B_A
15	VRL	PD11	16	SW1	PC00
17	SW2	PC01	18	LED1	PD15
19	LED2	PC06	20	LED3	PC07
21	HALL_U	PD12/IRQ12_B	22	HALL_V	PD13/IRQ13_B
23	HALL_W	PD14/IRQ13_B	24	MISO0/SIO_SDA	PC11/MISOB_B
25	SCK0/SCK_SCL	PC10	26	CSN_IRQN/ENC_Z	PD10/GTETRGC
27	IPS_A ENC_A	PC02 PD08/GTIOC2A_A	28	IPS_A#/ENC_A#	PC03/AN015
29	IPS_B ENC_B	PE11 PD09/GTIOC2B_A	30	IPS_B#/ENC_B#	PE12/AN024
31	GND	- (VSS)	32	GND	- (VSS)
33	+5V	-	34	+5V	-

The connection for CPU board and inverter board is shown in Figure 6-1. Please refer to 4.6.2 for the power supply method.

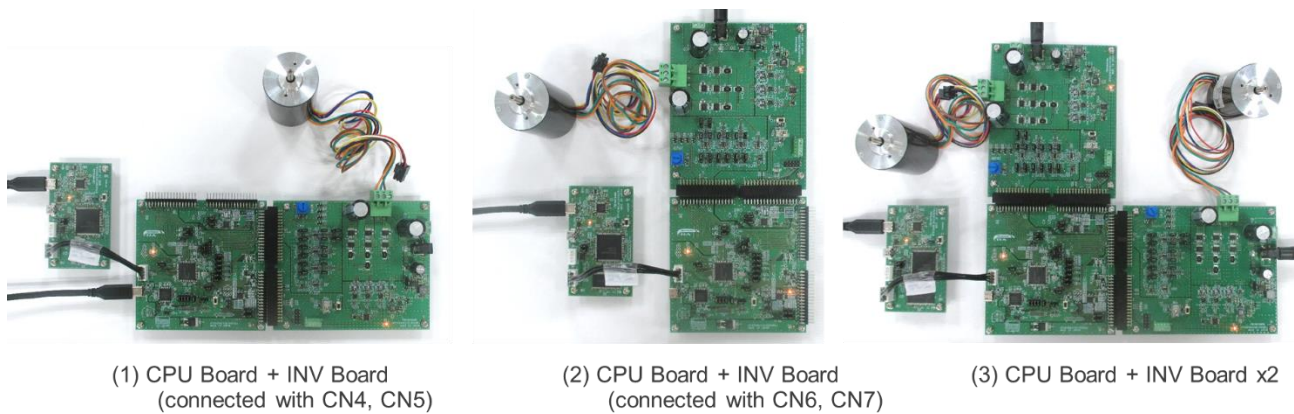

**Figure 6-1 Connection for CPU board and inverter board**

**6.1.4 Serial communication**

For serial communication using Renesas Motor Workbench, the CPU board has SCI connector. Pin assignment for SCI connector is listed in Table 6-5.

**Table 6-5 SCI connector (CN10) pin assignment**

Pin No.	Pin Function	RA6T2 Connection Pin
1	VCC	-
2	MCU TXD	PD05/TXD9_A
3	MCU RXD	PD06/RXD9_A
4	GND	-

**6.1.5 Reset circuit**

This product has a reset circuit to enable power-on reset or external reset on MCU. Push the tact switch (SW1) to externally reset MCU.

### 6.1.6 LED

This product has six ports and LEDs, so that they can be used for program debug and the system. LED switches on when output from the corresponding port is "LOW" and switches off when output is "HIGH". Pin assignment for corresponding LEDs is listed in Table 6-6.

**Table 6-6 LED pin assignment**

RA6T2 port		LED1	LED2	LED3	LED4	LED5	LED6
PD01	Output HIGH	OFF	-	-	-	-	-
	Output LOW	ON	-	-	-	-	-
PD02	Output HIGH	-	OFF	-	-	-	-
	Output LOW	-	ON	-	-	-	-
PD03	Output HIGH	-	-	OFF	-	-	-
	Output LOW	-	-	ON	-	-	-
PD15	Output HIGH	-	-	-	OFF	-	-
	Output LOW	-	-	-	ON	-	-
PC06	Output HIGH	-	-	-	-	OFF	-
	Output LOW	-	-	-	-	ON	-
PC07	Output HIGH	-	-	-	-	-	OFF
	Output LOW	-	-	-	-	-	ON

### 6.1.7 CAN Communication

This product has through holes for CAN communication. Note that CAN driver is not equipped. Pin assignment for CAN communication connector is listed in Table 6-7.

**Table 6-7 CAN communication pin assignment (CN8)**

Pin No	RA6T2 pin
1	VCC
2	PB13/CTX0_E
3	PB12/CRX0_E
4	VSS

### 6.1.8 SPI communication

This product has through holes for SPI communication. Pin Assignment for SPI communication connector is listed in Table 6-8.

**Table 6-8 SPI communication pin assignment (CN9)**

Pin No	RA6T2 pin
1	PD00_SS0
2	PC12_MOSI0
3	PC11_MISO0/SIO_SDA
4	PC10_SCK0/SCK_SCL
5	VSS
6	VCC

## 6.2 RA6T2 pin function list

Table 6-9 RA6T2 pin function list

Pin number	RA6T2 pin function	Signal function
1	PE02/TRCLK/CMPOUT0_C/GTOVLO_C/GTIOC7B_B/GTIOC8A_E/GT CPPO8/SCK0_B/DE0_D/SCK3_A/DE3_A/RSPCKB_C/CLKOUT_C	ARM debugger
2	PE03/TRDATA0/CMPOUT1_C/GTOWLO_C/GTIOC8A_B/GTIOC9A_E/ GTCPP06/RXD0_B/CTS3_A/SSLB0_C/GTODFMA	ARM debugger
3	PE04/TRDATA1/CMPOUT2_C/GTOUUP_C/GTIOC8B_B/GTIOC7B_E/ GTCPP09/TXD0_B/SS_CTS_RTS3_A/DE3_A/SSLB1_C/GTODFMB	ARM debugger
4	PE05/TRDATA2/CMPOUT3_C/GTOVUP_C/GTIOC9A_B/GTIOC8B_E/ GTCPP02/SS_CTS_RTS0_B/DE0_B/RXD3_A/MISOB_C/GTODFMC	ARM debugger
5	PE06/TRDATA3/GTOWUP_C/GTIOC9B_B/GTCPP03/CTS0_B/TXD3_ A/MOSIB_C/GTODFMD	ARM debugger
6	VCC	Power
7	PC13/GTETRGD/NMI	INV1 over current
8	PC14/ADTRG0_C/CMPOUT012_B/AGTWIO0_C/GTETRGA/GTIOC3A _D/GTCPP00/GTADSM0/GTCPP04/IRQ14_A/GTODFMC	INV1 Encoder_A
9	PC15/ADTRG1_C/CMPOUT345_B/AGTWIO1_C/GTETRGB/GTIOC3B _D/GTCPP01/GTADSM1/GTCPP07/IRQ15_A/GTODFMD	INV1 Encoder_B
10	VSS	Power
11	VCC	Power
12	P212/EXTAL	Xtal
13	P213/XTAL/IRQ0_C	Xtal
14	RES	ARM debugger
15	PC00/AN012 (AN012)/PGAOUT0/IVCMP00/IRQ11DS	INV2 SW1
16	PC01/AN013 (AN013)/PGAOUT1/IVCMP10/IRQ12DS	INV2 SW2
17	PC02/AN014 (AN014)/PGAOUT2/IVCMP20/IRQ13DS	INV2 PFC current detection/IPS_A
18	PC03/AN015 (AN015)/PGAOUT3/IVCMP30/IRQ14DS	INV2 PFC current detection/IPS_A #
19	P000/AN016 (AN016)/IVREF0/IRQ0_D	INV2 PFC over current detection
20	VREFL0	Power
21	VREFH0	Power
22	P001/AN017 (AN017)/IVREF1/IRQ2_C	INV1 PFC over current detection
23	PA00/AN000 (AN000)/PGAIN0/IVCMP02 / IVCMP03/IRQ0DS	INV1 W-phase current detection
24	PA01/AN001 (AN001)/PGAVSS0/IRQ1_A	INV1 W-phase voltage detection/PGAVSS_ W
25	PA02/AN002 (AN002)/PGAIN1/IVCMP12 / IVCMP13/IRQ2_A	INV1 V-phase current detection
26	PA03/AN003 (AN003)/PGAVSS1/IRQ3_A	INV1 V-phase voltage detection/PGAVSS_ V
27	AVSS0	Power
28	AVCC0	Power
29	PA04/AN004 (AN004)/PGAIN2/IVCMP22 / IVCMP23/IRQ4_A	INV1 U-phase current detection
30	PA05/AN005 (AN005)/PGAVSS2/IRQ5_A	INV1 PGAVSS_U
31	PA06/AN006 (AN106)/DA0/IRQ6_A	INV1 bus voltage detection
32	PA07/AN007 (AN107)/DA1/IRQ7_A	INV1 W-phase voltage detection
33	PC04/AN010 (AN110)/DA2/IRQ10_B	INV1 HALL_U/IPS_A
34	PC05/AN011 (AN111)/DA3/IRQ11_B	INV1 HALL_V/IPS_A#
35	PB00/AN008 (AN108)/PGAOUT0 / PGAOUT2/IRQ0_A	INV1 VR1 voltage detection
36	PB01/AN009 (AN109)/PGAOUT1 / PGAOUT3/IRQ1_B	INV1 HALL_W

Pin number	RA6T2 pin function	Signal function
37	PB02/AN018 (AN118)/PGAIN3/IVCMP32 / IVCMP33/IRQ15DS	INV2 U-phase current detection
38	P002/AN019 (AN119)/PGAVSS3	INV2 PGAVSS_U
39	PE08/AN020/AN120/ADTRG0_E/CMPOUT012_C/GTIV_B/GTIOC3A_B/GTETRGC/GTADSM0/SSLA3_C/KR00_E/GTODFMON	INV2 V-phase current detection
40	PE09/AN021/AN121/ADTRG1_E/CMPOUT345_C/GTIW_B/GTIOC3B_B/GTETRGD/GTADSM1/CACREF_F/SSLA2_C/KR01_E	INV2 W-phase current detection
41	PE10/AN022/AN122/GTOULO_B/GTIOC2A_B/GTIOC4A_C/GTIOC7A_D/SSLA1_C/KR02_E	INV2 U-phase voltage detection
42	PE11/AN023/AN123/GTOUUP_B/GTIOC2B_B/GTIOC5A_C/GTIOC8A_D/SSLA0_C/KR03_E	INV2 V-phase voltage detection /IPS_B
43	PE12/AN024/AN124/GTOVLO_B/GTIOC1A_B/GTIOC6A_C/GTIOC9A_D/RSPCKA_C/KR04_E	INV2 V-phase voltage detection/IPS_B#
44	PE13/AN025/AN125/GTOVUP_B/GTIOC1B_B/GTIOC4B_C/GTIOC7B_D/MISOA_C/KR05_E	INV2 bus voltage detection
45	PE14/AN026/AN126/GTOWLO_B/GTIOC0A_B/GTIOC5B_C/GTIOC8B_D/MOSIA_C/KR06_E	INV2 VR1 voltage detection
46	PE15/AN027/AN127/GTOWUP_B/GTIOC0B_B/GTIOC6B_C/GTIOC9B_D/RXD4_A/KR07_E	INV1 PFC current detection/IPS_B
47	PB10/AN028/AN128/GTIU_C/GTETRGA/GTETRGB/GTCPPO4/GTCPPO7/CACREF_C/TXD4_A/CTS3_B/IRQ10DS/VCOUT	INV1 PFC voltage detection/IPS_B#
48	VCL1	Power
49	VSS	Power
50	VCC	Power
51	PB12/ADTRG0_B/GTETRGA/GTIOC0A_A/GTIOC4A_F/CRX0_E/SCK4_A/DE4_A/RXD3_B/SSLB0_A/IRQ2_B	CAN_RX
52	PB13/GTOULO_A/GTIOC0B_A/GTIOC7A_C/GTIOC5A_F/CTX0_E/CTS4_A/TXD3_B/RSPCKB_A/IRQ3_B	CAN_TX
53	PB14/GTOVLO_A/GTIOC1A_A/GTIOC8A_C/GTIOC6A_F/SS_CTS_RT S4_A/DE4_A/SCK3_B/DE3_B/SDA0_C/MISOB_A/IRQ4_B	INV2 PFCPWM1
54	PB15/GTOWLO_A/GTIOC1B_A/GTIOC9A_C/GTIOC4B_F/RXD4_A/SS_CTS_RTS3_B/DE3_B/SCL0_C/MOSIB_A/IRQ5_B	INV1 PFCPWM2
55	PD08/GTIOC2A_A/CTS2_B/TXD1_A/SSLB1_A/KR00_D	INV2 Encoder_A
56	PD09/GTIOC2B_A/SS_CTS_RTS2_B/DE2_B/RXD1_A/SSLB2_A/KR01_D	INV2 Encoder_B
57	PD10/GTETRGC/GTIOC3A_A/SCK2_C/DE2_C/SCK1_A/DE1_A/SSLB3_A/KR02_D	INV2 Encoder_Z
58	PD11/GTIOC3B_A/RXD2_C/CTS1_A/KR03_D	INV2 Relay control
59	PD12/GTIOC4A_A/TXD2_C/SS_CTS_RTS1_A/DE1_A/SCL1_D/KR04_D/IRQ12_B/GTODFMA	INV2 HALL_U
60	PD13/GTIOC4B_A/SCK4_C/DE4_C/SCK9_C/DE9_C/SDA1_D/KR05_D/IRQ13_B/GTODFMB	INV2 HALL_V
61	PD14/GTIOC5A_A/RXD4_C/RXD9_C/SCL0_F/KR06_D/IRQ14_B/GTODFMC	INV2 HALL_W
62	PD15/GTIOC5B_A/TXD4_C/TXD9_C/DE9_C/SDA0_F/KR07_D/IRQ15_B/GTODFMD	INV2 LED1
63	PC06/AGTWO0_B/GTETRGD/GTIOC6A_A/GTIOC5B_F/TXD2_B/SS_CTS_RTS9_C/DE9_C/SCL1_E/IRQ6_B	INV2 LED2
64	PC07/AGTWEE0_B/GTETRGA/GTIOC6B_A/RXD2_B/CTS9_C/SDA1_E/IRQ7_B	INV2 LED3
65	PC08/AGTWOA0_B/GTIV_C/GTIOC7A_A/CACREF_D/SCK2_B/DE2_B/SS_CTS_RTS3_C/DE3_C/SCL0_D (SCL0_E)/SSLA3_B/IRQ8_B	INV2 PWM U-phase (Upper)
66	PC09/AGTWOB0_B/GTIW_C/GTIOC7B_A/GTIOC8A_F/SS_CTS_RTS2_B/DE2_B/CTS3_C/SDA0_D (SDA0_E)/SSLA2_B/IRQ9_B/CLKOUT_B	INV2 PWM U-phase (Lower)
67	PA08/CMPOUT2_A/AGTWIO0_B/GTOUUP_A/GTIOC8A_A/GTIOC7B_C/GTIOC2A_C/GTIOC9A_F/SCK0_A/DE0_A/SCK1_C/DE1_C/SCL0_D/SSLA1_B/KR00_B/IRQ8_A/CLKOUT_A	INV2 PWM V-phase (Upper)
68	PA09/CMPOUT3_A/GTOVUP_A/GTIOC8B_A/GTIOC8B_C/GTIOC2B_C/GTIOC7B_F/TXD0_A/SCL1_C/SSLA0_B/KR01_B/IRQ9_A	INV2 PWM V-phase (Lower)
69	PA10/CMPOUT0_A/GTOWUP_A/GTIOC9A_A/GTIOC9B_C/GTIOC3A	INV2 PWM W-phase

Pin number	RA6T2 pin function	Signal function
	_C/GTIOC8B_F/RXD0_A/SDA1_C/RSPCKA_B/KR02_B/IRQ10_A	(Upper)
70	PA11/CMPOUT1_A/GTETRGD/GTIOC9B_A/GTETRGC/GTIOC3B_C/CTX0_A/CTS0_A/RXD1_C/MOSIA_B/KR03_B/IRQ11_A	INV2 PWM W-phase (Lower)
71	PA12/ADTRG1_A/GTETRGB/GTCPPO0/GTCPPO2/GTADSM0/GTCPPO7/CACREF_A/CRX0_A/SS_CTS_RTS0_A/DE0_A/TXD1_C/MISOA_B/KR04_B/IRQ12_A/GTODFMA	INV2 over current detection/PFC over current detection
72	PA13/TMS/SWDIO/TMS/SWDIO/AGTWO0_A/SCK0_C/DE0_C/SS_CTS_RTS1_C/DE1_C	ARM debugger
73	VCL2	Power
74	VSS	Power
75	VCC	Power
76	PA14/TCK/SWCLK/AGTWO1_A/TXD0_C/SCK9_B/DE9_B	ARM debugger
77	PA15/TDI/ADTRG0_A/CMPOUT012_A/GTETRGB/GTADSM1/GTCPPO4/RXD0_C/RXD9_B/SSLA0_A/KR02_A/IRQ1_C/GTODFMB	ARM debugger
78	PC10/CMPOUT0_B/AGTWIO1_B/TXD1_B/SCL0_B[w/5VToI]/RSPCKB_B/KR05_B/IRQ6DS	SS
79	PC11/CMPOUT1_B/AGTWOA1_B/RXD1_B/SDA0_B[w/5VToI]/MISOB_B/KR06_B/IRQ7DS	MOSI
80	PC12/CMPOUT2_B/AGTWOB1_B/GTCPPO6/GTCPPO9/TXD4_B/SCK1_B/DE1_B/MOSIB_B/KR07_B/IRQ8DS/GTODFMON	MISO/SIO_SDA
81	PD00/GTADSM0/GTCPPO4/CRX0_F/CTS2_A/RXD3_C/SSLB0_B/KR00_C	SCK0/SCK_SCL
82	PD01/GTADSM1/GTCPPO7/CTX0_F/SS_CTS_RTS2_A/DE2_A/TXD3_C/SSLB1_B/KR01_C	INV1 LED1
83	PD02/CMPOUT3_B/AGTWEE1_B/GTCPPO0/GTCPPO2/RXD4_B/SCK3_C/DE3_C/KR02_C/IRQ9DS/CLKOUT_D	INV1 LED2
84	PD03/CMPOUT0_D/GTCPPO5/GTCPPO0/SCK4_B/DE4_B/CTS9_A/SSLB2_B/KR03_C	INV1 LED3
85	PD04/CMPOUT1_D/GTCPPO8/GTCPPO1/SS_CTS_RTS4_B/DE4_B/SS_CTS_RTS9_A/DE9_A/SSLB3_B/KR04_C	INV1 SW1
86	PD05/GTADSM0/GTCPPO3/TXD9_A/SDA1_B[w/5VToI]/SSLA3_A/KR05_C	RMW communication
87	PD06/GTCPPO4/RXD9_A/SCL1_B[w/5VToI]/SSLA2_A/KR06_C	RMW communication
88	PD07/GTADSM1/GTCPPO7/SCK9_A/DE9_A/SSLA1_A/KR07_C	INV1 SW2
89	PB03/TDO/TRACESWO/ADTRG1_B/CMPOUT345_A/AGTWO1_B/GTIOC4A_D/GTCPPO1/GTCPPO3/CRX0_D/TXD2_A/TXD9_B/RSPCKA_A/KR03_A/IRQ0_B/GTODFMON	ARM debugger
90	PB04/AGTWOA0_A/GTIOC4A_B/GTIOC5A_D/GTIOC0A_C/CACREF_B/CTX0_D/RXD2_A/RXD3_D/MISOA_A/KR04_A/IRQ13_A/VCOUT	INV1 PWM U-phase (Upper)
91	PB05/AGTWOB0_A/GTIU_A/GTIOC4B_B/GTIOC6A_D/GTIOC0B_C/CRX0_B/SCK2_A/DE2_A/TXD3_D/MOSIA_A/KR05_A/IRQ3DS/GTODFMON	INV1 PWM U-phase (Lower)
92	PB06/AGTWOA1_A/GTIV_A/GTIOC5A_B/GTIOC4B_D/GTIOC1A_C/CTX0_B/TXD0_D/SS_CTS_RTS3_D/DE3_D/SCL0_A[HSw/5VToI]/KR06_A/IRQ4DS/GTODFMA	INV1 PWM V-phase (Upper)
93	PB07/AGTWOB1_A/GTIW_A/GTIOC5B_B/GTETRGC/GTIOC1B_C/RXD0_D/SS_CTS_RTS1_D/DE1_D/SDA0_A[HSw/5VToI]/KR07_A/IRQ5DS/GTODFMB	INV1 PWM V-phase (Lower)
94	P201/MD	ARM debugger
95	PB08/AGTWIO0_A/GTIOC6A_B/GTIOC5B_D/GTIOC2A_D/CRX0_C/RXD4_C/RXD1_D/SCL1_A[w/5VToI]/KR00_A/IRQ1DS/GTODFMC	INV1 PWM W-phase (Upper)
96	PB09/AGTWIO1_A/GTIOC6B_B/GTIOC2B_D/CTX0_C/TXD4_C/TXD1_D/SDA1_A[w/5VToI]/KR01_A/IRQ2DS/GTODFMD	INV1 PWM W-phase (Lower)
97	PE00/ADTRG0_D/AGTWEE0_A/GTETRGA/GTIOC4A_F/GTADSM0/GTCPPO5/CACREF_E/TXD0_E/TXD9_D/SSLB3_	INV1 Encoder_Z
98	PE01/ADTRG1_D/AGTWEE1_A/GTOULO_C/GTIOC7A_B/GTIOC4B_F/GTADSM1/RXD0_E/RXD9_D/SSLB2_C	INV1 Relay control
99	VSS	Power
100	VCC	Power

## 7. Communication Board Specification

This section describes the specification of the communication board.

### 7.1 Functions

#### 7.1.1 Power supply

Power of this product is supplied at 5V from USB connector.

#### 7.1.2 USB communication

This product is equipped with a USB type-C connector for communication with a PC when using Renesas Motor Workbench, etc.

#### 7.1.3 Serial communication

This board has two SCI connectors for serial communication with the target MCU when using Renesas Motor Workbench, etc. The pin assignments are shown in Table 7-1 and Table 7-2. When using the communication cable bundled with this product, use CN5.

The serial communication connector and the MCU (RX72N) are connected via a digital isolator, so the communication board and the CPU board with the target MCU are isolated.

**Table 7-1 SCI connector (CN5) pin assignment**

Pin No.	Function	Note
1	VCC	
2	RXD	Connect to TXD of target MCU
3	TXD	Connect to RXD of target MCU
4	GND	

**Table 7-2 SCI connector (CN4) pin assignment**

Pin No.	Function	Note
1	VCC	
2	RXD	Connect to TXD of target MCU
3	TXD	Connect to RXD of target MCU
4	GND	



## 8. Design and Manufacture Information

You can obtain information on the design and manufacture of this product from [renesas.com](https://www.renesas.com).

## 9. Website and Support

In order to learn, download tools and documents, apply technical support for RA family MCU and its kit, visit the below Web site.

- RA Product Information [renesas.com/ra](https://www.renesas.com/ra)
- RA Product Support Forum [renesas.com/ra/forum](https://www.renesas.com/ra/forum)
- Renesas Support [renesas.com/support](https://www.renesas.com/support)



Revision History	MCK-RA6T2 User's Manual
------------------	-------------------------

Rev.	Date	Description	
		Page	Summary
1.00	August 3, 2021	-	First edition

---

MCK-RA6T2 User's Manual

Publication Date: Rev 1.00 August 3, 2021

Published by: Renesas Electronics Corporation

---

# MCK-RA6T2 User's Manual



Renesas Electronics Corporation

R12UZ0091EJ0100