



### FEATURES

Ultra-low power consumption (10Mbps): 0.58mA/Channel

High data rate: 10Mbps

High common-mode transient immunity:

$\pi$ 14xx3x: 75 kV/ $\mu$ s typical

$\pi$ 14xx6x: 120 kV/ $\mu$ s typical

High robustness to radiated and conducted noise

Low propagation delay: 9 ns typical

Isolation voltages:

$\pi$ 14xx3x: AC 3000Vrms

$\pi$ 14xx6x: AC 5000Vrms

High ESD rating:

ESDA/JEDEC JS-001-2017

Human body model (HBM)  $\pm$ 8kV

Safety and regulatory approvals:

UL certificate number: E494497

3000Vrms/5000Vrms for 1 minute per UL 1577

CSA Component Acceptance Notice 5A

VDE certificate number: 40053041/40052896

DIN VDE V 0884-11:2017-01

$V_{IORM} = 565V$  peak/1200V peak

CQC certification per GB4943.1-2011

3 V to 5.5 V level translation

Wide temperature range:  $-40^{\circ}C$  to  $125^{\circ}C$

RoHS-compliant, NB SOIC-16, WB SOIC-16,

SSOP16 package

### APPLICATIONS

General-purpose multichannel isolation

Industrial field bus isolation

Isolation Industrial automation systems

Isolated switch mode supplies

Isolated ADC, DAC

Motor control

### GENERAL DESCRIPTION

The  $\pi$ 1xxxx is a 2PaiSemi digital isolators product family that includes over hundreds of digital isolator products. By using matured standard semiconductor CMOS technology and 2PaiSEMI *iDivider*<sup>®</sup> technology, these isolation components provide outstanding performance characteristics and reliability superior to alternatives such as optocoupler devices and other integrated isolators.

Intelligent voltage divider technology (*iDivider*<sup>®</sup> technology) is a new generation digital isolator technology invented by 2PaiSEMI.

It uses the principle of capacitor voltage divider to transmit voltage signal directly cross the isolator capacitor without signal modulation and demodulation.

The  $\pi$ 1xxxx isolator data channels are independent and are available in a variety of configurations with a withstand voltage rating of 1.5 kV rms to 5.0 kV rms and the data rate from DC up to 600Mbps (see the Ordering Guide). The devices operate with the supply voltage on either side ranging from 3.0 V to 5.5 V, providing compatibility with lower voltage systems as well as enabling voltage translation functionality across the isolation barrier. The fail-safe state is available in which the outputs transition to a preset state when the input power supply is not applied.

### FUNCTIONAL BLOCK DIAGRAMS

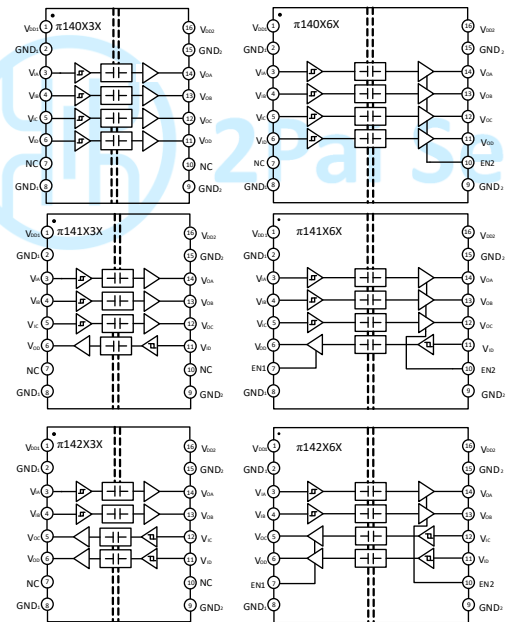

Figure 1.  $\pi$ 140xxx/ $\pi$ 141xxx/ $\pi$ 142xxx functional Block Diagram

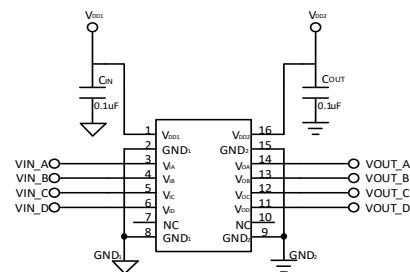

Figure 2.  $\pi$ 140x3x Typical Application Circuit

## PIN CONFIGURATIONS AND FUNCTIONS

Table 1.  $\pi$ 140Mxx Pin Function Descriptions

Pin No.	Name	Description
1	V <sub>DD1</sub>	Supply Voltage for Isolator Side 1.
2	GND <sub>1</sub>	Ground 1. This pin is the ground reference for Isolator Side 1.
3	V <sub>IA</sub>	Logic Input A.
4	V <sub>IB</sub>	Logic Input B.
5	V <sub>IC</sub>	Logic Input C.
6	V <sub>ID</sub>	Logic Input D.
7	NC	No connect.
8	GND <sub>1</sub>	Ground 1. This pin is the ground reference for Isolator Side 1.
9	GND <sub>2</sub>	Ground 2. This pin is the ground reference for Isolator Side 2.
10	NC /EN2	No connect for $\pi$ 140M3X.
		Output enable for $\pi$ 140M6X. Output pins on side 2 are enabled when EN2 is high or open and in high-impedance state when EN2 is low.
11	V <sub>OD</sub>	Logic Output D.
12	V <sub>OC</sub>	Logic Output C.
13	V <sub>OB</sub>	Logic Output B.
14	V <sub>OA</sub>	Logic Output A.
15	GND <sub>2</sub>	Ground 2. This pin is the ground reference for Isolator Side 2.
16	V <sub>DD2</sub>	Supply Voltage for Isolator Side 2.

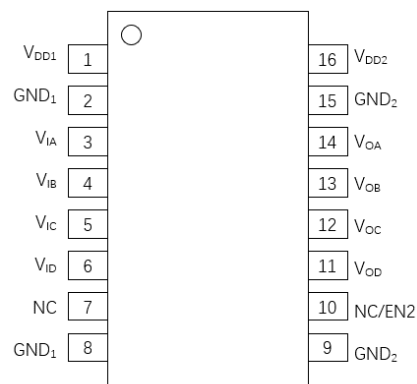

Figure 3.  $\pi$ 140Mxx Pin Configuration

Table 2.  $\pi$ 141Mxx Pin Function Descriptions

Pin No.	Name	Description
1	V <sub>DD1</sub>	Supply Voltage for Isolator Side 1.
2	GND <sub>1</sub>	Ground 1. This pin is the ground reference for Isolator Side 1.
3	V <sub>IA</sub>	Logic Input A.
4	V <sub>IB</sub>	Logic Input B.
5	V <sub>IC</sub>	Logic Input C.
6	V <sub>OD</sub>	Logic Output D.
7	NC/EN1	No connect for $\pi$ 141M3X.
		Output enable 1 for $\pi$ 141M6X. Output pins on side 1 are enabled when EN1 is high or open and in high-impedance state when EN1 is low.
8	GND <sub>1</sub>	Ground 1. This pin is the ground reference for Isolator Side 1.
9	GND <sub>2</sub>	Ground 2. This pin is the ground reference for Isolator Side 2.
10	NC/EN2	No connect for $\pi$ 141M3X.
		Output enable 2 for $\pi$ 141M6X. Output pins on side 2 are enabled when EN2 is high or open and in high-impedance state when EN2 is low.
11	V <sub>ID</sub>	Logic Input D.
12	V <sub>OC</sub>	Logic Output C.
13	V <sub>OB</sub>	Logic Output B.
14	V <sub>OA</sub>	Logic Output A.
15	GND <sub>2</sub>	Ground 2. This pin is the ground reference for Isolator Side 2.
16	V <sub>DD2</sub>	Supply Voltage for Isolator Side 2.

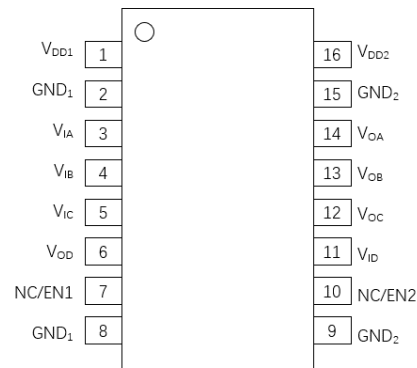

Figure 4.  $\pi$ 141Mxx Pin Configuration

Table 3.  $\pi$ 142Mxx Pin Function Descriptions

Pin No.	Name	Description
1	V <sub>DD1</sub>	Supply Voltage for Isolator Side 1.
2	GND <sub>1</sub>	Ground 1. This pin is the ground reference for Isolator Side 1.
3	V <sub>IA</sub>	Logic Input A.
4	V <sub>IB</sub>	Logic Input B.
5	V <sub>OC</sub>	Logic Output C.
6	V <sub>OD</sub>	Logic Output D.
7	NC/EN1	No connect for $\pi$ 142M3X.
		Output enable 1 for $\pi$ 142M6X. Output pins on side 1 are enabled when EN1 is high or open and in high-impedance state when EN1 is low.
8	GND <sub>1</sub>	Ground 1. This pin is the ground reference for Isolator Side 1.
9	GND <sub>2</sub>	Ground 2. This pin is the ground reference for Isolator Side 2.
10	NC/EN2	No connect for $\pi$ 142M3X.
		Output enable 2 for $\pi$ 142M6X. Output pins on side 2 are enabled when EN2 is high or open and in high-impedance state when EN2 is low.
11	V <sub>ID</sub>	Logic Input D.
12	V <sub>IC</sub>	Logic Input C.
13	V <sub>OB</sub>	Logic Output B.
14	V <sub>OA</sub>	Logic Output A.
15	GND <sub>2</sub>	Ground 2. This pin is the ground reference for Isolator Side 2.
16	V <sub>DD2</sub>	Supply Voltage for Isolator Side 2.

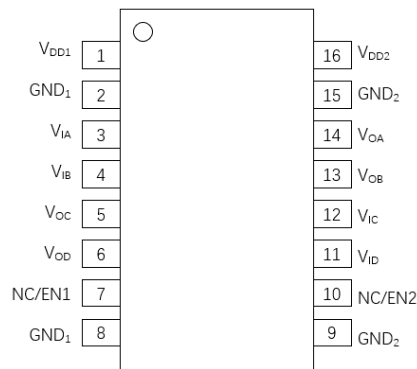

Figure 5.  $\pi$ 142Mxx Pin Configuration

## ABSOLUTE MAXIMUM RATINGS

T<sub>A</sub> = 25°C, unless otherwise noted.

Table 4. Absolute Maximum Ratings<sup>4</sup>

Parameter	Rating
Supply Voltages (V <sub>DD1</sub> -GND <sub>1</sub> , V <sub>DD2</sub> -GND <sub>2</sub> )	-0.5 V to +7.0 V
Input Voltages (V <sub>IA</sub> , V <sub>IB</sub> ) <sup>1</sup>	-0.5 V to V <sub>DDx</sub> + 0.5 V
Output Voltages (V <sub>OA</sub> , V <sub>OB</sub> ) <sup>1</sup>	-0.5 V to V <sub>DDx</sub> + 0.5 V
Average Output Current per Pin <sup>2</sup> Side 1 Output Current (I <sub>O1</sub> )	-10 mA to +10 mA
Average Output Current per Pin <sup>2</sup> Side 2 Output Current (I <sub>O2</sub> )	-10 mA to +10 mA
Common-Mode Transients Immunity <sup>3</sup>	-200 kV/μs to +200 kV/μs
Storage Temperature (T <sub>ST</sub> ) Range	-65°C to +150°C
Ambient Operating Temperature (T <sub>A</sub> ) Range	-40°C to +125°C

Notes:

<sup>1</sup> V<sub>DDx</sub> is the side voltage power supply V<sub>DD</sub>, where x = 1 or 2.

<sup>2</sup> See Figure 6 for the maximum rated current values for various temperatures.

<sup>3</sup> See Figure 13 for Common-mode transient immunity (CMTI) measurement.

<sup>4</sup> Stresses at or above those listed under Absolute Maximum Ratings may cause permanent damage to the device. These are stress rating only; functional operation of the device at these or any other conditions above those indicated in the operational section of this specification is not implied. Operation beyond the maximum operating conditions for extended periods may affect product reliability.

## RECOMMENDED OPERATING CONDITIONS

Table 5. Recommended Operating Conditions

Parameter	Symbol	Min	Typ	Max	Unit
Supply Voltage	V <sub>DDx</sub> <sup>1</sup>	3		5.5	V
High Level Input Signal Voltage	V <sub>IH</sub>	0.7*V <sub>DDx</sub> <sup>1</sup>		V <sub>DDx</sub> <sup>1</sup>	V

Parameter	Symbol	Min	Typ	Max	Unit
Low Level Input Signal Voltage	$V_{IL}$	0		$0.3 * V_{DDx}^1$	V
High Level Output Current	$I_{OH}$	-6			mA
Low Level Output Current	$I_{OL}$			6	mA
Data Rate		0		10	Mbps
Junction Temperature	$T_J$	-40		150	°C
Ambient Operating Temperature	$T_A$	-40		125	°C

Notes:

<sup>1</sup>  $V_{DDx}$  is the side voltage power supply  $V_{DD}$ , where  $x = 1$  or  $2$ .

## Truth Tables

Table 6.  $\pi 140M3x/\pi 141M3x/\pi 142M3x$  Truth Table

$V_{ix}$ Input <sup>1</sup>	$V_{DDI}$ State <sup>1</sup>	$V_{DDO}$ State <sup>1</sup>	Default Low $V_{Ox}$ Output <sup>1</sup>	Default High $V_{Ox}$ Output <sup>1</sup>	Test Conditions /Comments
Low	Powered <sup>2</sup>	Powered <sup>2</sup>	Low	Low	Normal operation
High	Powered <sup>2</sup>	Powered <sup>2</sup>	High	High	Normal operation
Open	Powered <sup>2</sup>	Powered <sup>2</sup>	Low	High	Default output
Don't Care <sup>4</sup>	Unpowered <sup>3</sup>	Powered <sup>2</sup>	Low	High	Default output <sup>5</sup>
Don't Care <sup>4</sup>	Powered <sup>2</sup>	Unpowered <sup>3</sup>	High Impedance	High Impedance	

Notes:

<sup>1</sup>  $V_{ix}/V_{Ox}$  are the input/output signals of a given channel (A or B).  $V_{DDI}/V_{DDO}$  are the supply voltages on the input/output signal sides of this given channel.<sup>2</sup> Powered means  $V_{DDx} \geq 2.95$  V<sup>3</sup> Unpowered means  $V_{DDx} < 2.30$  V<sup>4</sup> Input signal ( $V_{ix}$ ) must be in a low state to avoid powering the given  $V_{DDI}$  through its ESD protection circuitry.<sup>5</sup> If the  $V_{DDI}$  goes into unpowered status, the channel outputs the default logic signal after around 1 $\mu$ s. If the  $V_{DDI}$  goes into powered status, the channel outputs the input status logic signal after around 3 $\mu$ s.Table 7.  $\pi 140M6x/\pi 141M6x/\pi 142M6x$  Truth Table

$V_{ix}$ Input <sup>1</sup>	EN1/2 State	$V_{DDI}$ State <sup>1</sup>	$V_{DDO}$ State <sup>1</sup>	Default Low $V_{Ox}$ Output <sup>1</sup>	Default High $V_{Ox}$ Output <sup>1</sup>	Test Conditions /Comments
Low	High or NC	Powered <sup>2</sup>	Powered <sup>2</sup>	Low	Low	Normal operation
High	High or NC	Powered <sup>2</sup>	Powered <sup>2</sup>	High	High	Normal operation
Don't Care <sup>4</sup>	L	Powered <sup>2</sup>	Powered <sup>2</sup>	High Impedance	High Impedance	Disabled
Open	High or NC	Powered <sup>2</sup>	Powered <sup>2</sup>	Low	High	Default output <sup>5</sup>
Don't Care <sup>4</sup>	High or NC	Unpowered <sup>3</sup>	Powered <sup>2</sup>	Low	High	Default output <sup>5</sup>
Don't Care <sup>4</sup>	L	Unpowered <sup>3</sup>	Powered <sup>2</sup>	High Impedance	High Impedance	
Don't Care <sup>4</sup>	Don't Care <sup>4</sup>	Powered <sup>2</sup>	Unpowered <sup>3</sup>	High Impedance	High Impedance	

Notes:

<sup>1</sup>  $V_{ix}/V_{Ox}$  are the input/output signals of a given channel (A or B).  $V_{DDI}/V_{DDO}$  are the supply voltages on the input/output signal sides of this given channel.<sup>2</sup> Powered means  $V_{DDx} \geq 2.95$  V<sup>3</sup> Unpowered means  $V_{DDx} < 2.30$  V<sup>4</sup> Input signal ( $V_{ix}$ ) must be in a low state to avoid powering the given  $V_{DDI}$  through its ESD protection circuitry.<sup>5</sup> If the  $V_{DDI}$  goes into unpowered status, the channel outputs the default logic signal after around 1 $\mu$ s. If the  $V_{DDI}$  goes into powered status, the channel outputs the input status logic signal after around 3 $\mu$ s.

## SPECIFICATIONS

### ELECTRICAL CHARACTERISTICS

Table 8.  $\pi 14xM3x$  Switching Specifications $V_{DD1} - V_{GND1} = V_{DD2} - V_{GND2} = 3.3V_{DC} \pm 10\%$  or  $5V_{DC} \pm 10\%$ ,  $T_A = 25^\circ\text{C}$ , unless otherwise noted.

Parameter	Symbol	Min	Typ	Max	Unit	Test Conditions/Comments
Minimum Pulse Width	PW			100	ns	Within pulse width distortion (PWD) limit

Parameter	Symbol	Min	Typ	Max	Unit	Test Conditions/Comments
Maximum Data Rate		10			Mbps	Within PWD limit
Propagation Delay Time <sup>1</sup>	$t_{pHL}, t_{pLH}$	5.5	8	12.5	ns	5V <sub>DC</sub> supply
		6.5	9	13.5	ns	3.3V <sub>DC</sub> supply
Pulse Width Distortion	PWD	0.3	3.0		ns	The max different time between $t_{pHL}$ and $t_{pLH}$ @ 5V <sub>DC</sub> supply. And The value is $ t_{pHL} - t_{pLH} $
		0.4	3.0		ns	The max different time between $t_{pHL}$ and $t_{pLH}$ @ 3.3V <sub>DC</sub> supply. And The value is $ t_{pHL} - t_{pLH} $
Part to Part Propagation Delay Skew	$t_{PSK}$			2	ns	The max different propagation delay time between any two devices at the same temperature, load and voltage @ 5V <sub>DC</sub> supply
				2	ns	The max different propagation delay time between any two devices at the same temperature, load and voltage @ 3.3V <sub>DC</sub> supply
Channel to Channel Propagation Delay Skew	$t_{CSK}$	0	1.8		ns	The max amount propagation delay time differs between any two output channels in the single device @ 5V <sub>DC</sub> supply.
		0	2		ns	The max amount propagation delay time differs between any two output channels in the single device @ 3.3V <sub>DC</sub> supply
Output Signal Rise/Fall Time <sup>4</sup>	$t_r/t_f$		1.5		ns	See Figure 10.
Dynamic Input Supply Current per Channel	$I_{DDI(D)}$		9		$\mu$ A /Mbps	Inputs switching, 50% duty cycle square wave, CL = 0 pF @ 5V <sub>DC</sub> Supply
Dynamic Output Supply Current per Channel	$I_{DDO(D)}$		38		$\mu$ A /Mbps	
Dynamic Input Supply Current per Channel	$I_{DDI(D)}$		5		$\mu$ A /Mbps	
Dynamic Output Supply Current per Channel	$I_{DDO(D)}$		23		$\mu$ A /Mbps	
Common-Mode Transient Immunity <sup>3</sup>	CMTI		75		kV/ $\mu$ s	
Jitter			120		ps p-p	See the Jitter Measurement section
			20		ps rms	
ESD(HBM - Human body model)	ESD		$\pm$ 8		kV	

Notes:

<sup>1</sup>  $t_{pLH}$  = low-to-high propagation delay time,  $t_{pHL}$  = high-to-low propagation delay time. See Figure 11.<sup>2</sup>  $V_{DDx}$  is the side voltage power supply VDD, where x = 1 or 2.<sup>3</sup> See Figure 13 for Common-mode transient immunity (CMTI) measurement.<sup>4</sup>  $t_r$  means is the time from 10% amplitude to 90% amplitude of the rising edge of the signal,  $t_f$  means is the time from 90% amplitude to 10% amplitude of the falling edge of the signal.Table 9.  $\pi$ 14xM6x Switching Specifications $V_{DD1} - V_{GND1} = V_{DD2} - V_{GND2} = 3.3V_{DC} \pm 10\%$  or  $5V_{DC} \pm 10\%$ ,  $T_A = 25^\circ\text{C}$ , unless otherwise noted.

Parameter	Symbol	Min	Typ	Max	Unit	Test Conditions/Comments
Minimum Pulse Width	PW			100	ns	Within pulse width distortion (PWD) limit
Maximum Data Rate		10			Mbps	Within PWD limit
Propagation Delay Time <sup>1</sup>	$t_{pHL}, t_{pLH}$	12	16		ns	5V <sub>DC</sub> supply
		14	18.5		ns	3.3V <sub>DC</sub> supply
Pulse Width Distortion	PWD	0.3	3.0		ns	The max different time between $t_{pHL}$ and $t_{pLH}$ @ 5V <sub>DC</sub> supply. And The value is $ t_{pHL} - t_{pLH} $

Parameter	Symbol	Min	Typ	Max	Unit	Test Conditions/Comments
			0.4	3.0	ns	The max different time between $t_{pHL}$ and $t_{pLH}$ @ 3.3V <sub>DC</sub> supply. And The value is $ t_{pHL} - t_{pLH} $
Part to Part Propagation Delay Skew	$t_{psk}$			2	ns	The max different propagation delay time between any two devices at the same temperature, load and voltage @ 5V <sub>DC</sub> supply
				2	ns	The max different propagation delay time between any two devices at the same temperature, load and voltage @ 3.3V <sub>DC</sub> supply
Channel to Channel Propagation Delay Skew	$t_{csk}$		0	1.8	ns	The max amount propagation delay time differs between any two output channels in the single device @ 5V <sub>DC</sub> supply.
			0	2	ns	The max amount propagation delay time differs between any two output channels in the single device @ 3.3V <sub>DC</sub> supply
Output Signal Rise/Fall Time <sup>4</sup>	$t_r/t_f$		1.5		ns	See Figure 10.
Dynamic Input Supply Current per Channel	$I_{DDI(D)}$		10		$\mu$ A /Mbps	Inputs switching, 50% duty cycle square wave, CL = 0 pF @ 5V <sub>DC</sub> Supply
Dynamic Output Supply Current per Channel	$I_{DDO(D)}$		45		$\mu$ A /Mbps	
Dynamic Input Supply Current per Channel	$I_{DDI(D)}$		9		$\mu$ A /Mbps	Inputs switching, 50% duty cycle square wave, CL = 0 pF @ 3.3V <sub>DC</sub> Supply
Dynamic Output Supply Current per Channel	$I_{DDO(D)}$		28		$\mu$ A /Mbps	
Common-Mode Transient Immunity <sup>3</sup>	CMTI		120		kV/ $\mu$ s	$V_{IN} = V_{DDx}^2$ or 0V, $V_{CM} = 1000$ V
Jitter			180		ps p-p	See the Jitter Measurement section
			30		ps rms	
ESD(HBM - Human body model)	ESD		$\pm$ 8		kV	

Notes:

<sup>1</sup> $t_{pLH}$  = low-to-high propagation delay time,  $t_{pHL}$  = high-to-low propagation delay time. See Figure 11.

<sup>2</sup> $V_{DDx}$  is the side voltage power supply VDD, where x = 1 or 2.

<sup>3</sup>See Figure 13 for Common-mode transient immunity (CMTI) measurement.

<sup>4</sup> $t_r$  means is the time from 10% amplitude to 90% amplitude of the rising edge of the signal,  $t_f$  means is the time from 90% amplitude to 10% amplitude of the falling edge of the signal.

Table 10.DC Specifications

$V_{DD1} - V_{GND1} = V_{DD2} - V_{GND2} = 3.3V_{DC} \pm 10\%$  or  $5V_{DC} \pm 10\%$ ,  $T_A = 25^\circ C$ , unless otherwise noted.

	Symbol	Min	Typ	Max	Unit	Test Conditions/Comments
Rising Input Signal Voltage Threshold	$V_{IT+}$		$0.6 * V_{DDx}^1$	$0.7 * V_{DDx}^1$	V	
Falling Input Signal Voltage Threshold	$V_{IT-}$	$0.3 * V_{DDx}^1$	$0.4 * V_{DDx}^1$		V	
High Level Output Voltage	$V_{OH}^1$	$V_{DDx} - 0.1$	$V_{DDx}$		V	-20 $\mu$ A output current
		$V_{DDx} - 0.2$	$V_{DDx} - 0.1$		V	-2 mA output current
Low Level Output Voltage	$V_{OL}$		0	0.1	V	20 $\mu$ A output current
			0.1	0.2	V	2 mA output current
Input Current per Signal Channel	$I_{IN}$	-10	0.5	10	$\mu$ A	$0 V \leq$ Signal voltage $\leq V_{DDx}^1$
$V_{DDx}^1$ Undervoltage Rising Threshold	$V_{DDxUV+}$	2.45	2.75	2.95	V	
$V_{DDx}^1$ Undervoltage Falling Threshold	$V_{DDxUV-}$	2.30	2.60	2.75	V	
$V_{DDx}^1$ Hysteresis	$V_{DDxUVH}$		0.15		V	

Notes:

<sup>1</sup> $V_{DDx}$  is the side voltage power supply VDD, where x = 1 or 2.

Table 11.Quiescent Supply Current

$V_{DD1} - V_{GND1} = V_{DD2} - V_{GND2} = 3.3V_{DC} \pm 10\%$  or  $5V_{DC} \pm 10\%$ ,  $T_A = 25^\circ C$ ,  $C_L = 0$  pF, unless otherwise noted.

Part	Symbol	Min	Typ	Max	Unit	Test Conditions	
						Supply voltage	Input signal
$\pi 140M3x$	$I_{DD1}(Q)$	0.13	0.16	0.21	mA	$5V_{DC}$	$V_I = 0V$ for $\pi 14xMx0$
	$I_{DD2}(Q)$	1.56	1.95	2.54	mA		$V_I = 5V$ for $\pi 14xMx1$
	$I_{DD1}(Q)$	0.32	0.39	0.51	mA	$3.3V_{DC}$	$V_I = 5V$ for $\pi 14xMx0$
	$I_{DD2}(Q)$	1.48	1.85	2.40	mA		$V_I = 0V$ for $\pi 14xMx1$
	$I_{DD1}(Q)$	0.13	0.16	0.21	mA		$V_I = 0V$ for $\pi 14xMx0$
	$I_{DD2}(Q)$	1.54	1.93	2.51	mA		$V_I = 3.3V$ for $\pi 14xMx1$
$\pi 141M3x$	$I_{DD1}(Q)$	0.48	0.60	0.79	mA	$5V_{DC}$	$V_I = 0V$ for $\pi 14xMx0$
	$I_{DD2}(Q)$	1.20	1.50	1.95	mA		$V_I = 5V$ for $\pi 14xMx1$
	$I_{DD1}(Q)$	0.59	0.74	0.97	mA	$3.3V_{DC}$	$V_I = 5V$ for $\pi 14xMx0$
	$I_{DD2}(Q)$	1.17	1.47	1.91	mA		$V_I = 0V$ for $\pi 14xMx1$
	$I_{DD1}(Q)$	0.48	0.60	0.78	mA		$V_I = 0V$ for $\pi 14xMx0$
	$I_{DD2}(Q)$	1.19	1.48	1.93	mA		$V_I = 3.3V$ for $\pi 14xMx1$
$\pi 142M3x$	$I_{DD1}(Q)$	0.84	1.05	1.36	mA	$5V_{DC}$	$V_I = 0V$ for $\pi 14xMx0$
	$I_{DD2}(Q)$	0.84	1.05	1.36	mA		$V_I = 5V$ for $\pi 14xMx1$
	$I_{DD1}(Q)$	0.87	1.09	1.42	mA	$3.3V_{DC}$	$V_I = 5V$ for $\pi 14xMx0$
	$I_{DD2}(Q)$	0.87	1.09	1.42	mA		$V_I = 0V$ for $\pi 14xMx1$
	$I_{DD1}(Q)$	0.83	1.04	1.35	mA		$V_I = 0V$ for $\pi 14xMx0$
	$I_{DD2}(Q)$	0.83	1.04	1.35	mA		$V_I = 3.3V$ for $\pi 14xMx1$
$\pi 140M6x$	$I_{DD1}(Q)$	0.11	0.13	0.21	mA	$5V_{DC}$	$V_I = 0V$ for $\pi 14xMx0$
	$I_{DD2}(Q)$	1.56	2.18	2.93	mA		$V_I = 5V$ for $\pi 14xMx1$
	$I_{DD1}(Q)$	0.32	0.56	0.79	mA	$3.3V_{DC}$	$V_I = 5V$ for $\pi 14xMx0$
	$I_{DD2}(Q)$	1.48	2.00	2.72	mA		$V_I = 0V$ for $\pi 14xMx1$
	$I_{DD1}(Q)$	0.10	0.12	0.21	mA		$V_I = 0V$ for $\pi 14xMx0$
	$I_{DD2}(Q)$	1.54	2.11	2.85	mA		$V_I = 3.3V$ for $\pi 14xMx1$
$\pi 141M6x$	$I_{DD1}(Q)$	0.23	0.35	0.49	mA	$5V_{DC}$	$V_I = 3.3V$ for $\pi 14xMx0$
	$I_{DD2}(Q)$	1.42	1.94	2.62	mA		$V_I = 0V$ for $\pi 14xMx1$
	$I_{DD1}(Q)$	0.50	0.63	0.82	mA	$3.3V_{DC}$	$V_I = 0V$ for $\pi 14xMx0$
	$I_{DD2}(Q)$	1.28	1.60	2.07	mA		$V_I = 5V$ for $\pi 14xMx1$
	$I_{DD1}(Q)$	0.75	0.94	1.22	mA		$V_I = 5V$ for $\pi 14xMx0$
	$I_{DD2}(Q)$	1.17	1.47	1.91	mA		$V_I = 0V$ for $\pi 14xMx1$
$\pi 142M6x$	$I_{DD1}(Q)$	0.48	0.60	0.78	mA	$5V_{DC}$	$V_I = 0V$ for $\pi 14xMx0$
	$I_{DD2}(Q)$	1.24	1.55	2.01	mA		$V_I = 3.3V$ for $\pi 14xMx1$
	$I_{DD1}(Q)$	0.61	0.77	1.00	mA	$3.3V_{DC}$	$V_I = 3.3V$ for $\pi 14xMx0$
	$I_{DD2}(Q)$	1.13	1.42	1.84	mA		$V_I = 0V$ for $\pi 14xMx1$
	$I_{DD1}(Q)$	0.89	1.12	1.46	mA		$V_I = 0V$ for $\pi 14xMx0$
	$I_{DD2}(Q)$	0.89	1.12	1.46	mA		$V_I = 5V$ for $\pi 14xMx1$
$\pi 140M6x$	$I_{DD1}(Q)$	1.00	1.25	1.63	mA	$5V_{DC}$	$V_I = 5V$ for $\pi 14xMx0$
	$I_{DD2}(Q)$	1.00	1.25	1.63	mA		$V_I = 0V$ for $\pi 14xMx1$
	$I_{DD1}(Q)$	0.86	1.08	1.41	mA	$3.3V_{DC}$	$V_I = 0V$ for $\pi 14xMx0$
	$I_{DD2}(Q)$	0.86	1.08	1.41	mA		$V_I = 3.3V$ for $\pi 14xMx1$
	$I_{DD1}(Q)$	0.89	1.12	1.45	mA		$V_I = 3.3V$ for $\pi 14xMx0$
	$I_{DD2}(Q)$	0.89	1.12	1.45	mA		$V_I = 0V$ for $\pi 14xMx1$

Part	Symbol	Min	Typ	Max	Unit	Test Conditions	
						Supply voltage	Input signal
							V <sub>I</sub> =0V for $\pi$ 14xMx1
	I <sub>DD2</sub> (Q)	0.89	1.12	1.45	mA		

Table 12.Total Supply Current vs. Data Throughput (CL = 0 pF)

V<sub>DD1</sub> - V<sub>GND1</sub> = V<sub>DD2</sub> - V<sub>GND2</sub> = 3.3V<sub>DC</sub>±10% or 5V<sub>DC</sub>±10%, T<sub>A</sub>=25°C, C<sub>L</sub> = 0 pF, unless otherwise noted.

Part	Symbol	150 Kbps			1 Mbps			10 Mbps			Unit	Supply voltage
		Min	Typ	Max	Min	Typ	Max	Min	Typ	Max		
$\pi$ 140M3x	I <sub>DD1</sub>		0.28	0.42		0.30	0.45		0.48	0.72	mA	5V <sub>DC</sub>
	I <sub>DD2</sub>		1.90	2.85		2.04	3.06		3.52	5.28		
	I <sub>DD1</sub>		0.22	0.33		0.24	0.36		0.36	0.54	mA	3.3V <sub>DC</sub>
	I <sub>DD2</sub>		1.86	2.79		1.94	2.91		2.86	4.29		
$\pi$ 141M3x	I <sub>DD1</sub>		0.68	1.02		0.73	1.10		1.21	1.82	mA	5V <sub>DC</sub>
	I <sub>DD2</sub>		1.49	2.24		1.60	2.40		2.73	4.10		
	I <sub>DD1</sub>		0.63	0.95		0.66	0.99		0.95	1.43	mA	3.3V <sub>DC</sub>
	I <sub>DD2</sub>		1.45	2.18		1.51	2.27		2.20	3.30		
$\pi$ 142M3x	I <sub>DD1</sub>		1.08	1.62		1.16	1.74		1.94	2.91	mA	5V <sub>DC</sub>
	I <sub>DD2</sub>		1.08	1.62		1.16	1.74		1.94	2.91		
	I <sub>DD1</sub>		1.04	1.56		1.08	1.62		1.54	2.31	mA	3.3V <sub>DC</sub>
	I <sub>DD2</sub>		1.04	1.56		1.08	1.62		1.54	2.31		
$\pi$ 140M6x	I <sub>DD1</sub>		0.36	0.54		0.39	0.59		1.00	1.49	mA	5V <sub>DC</sub>
	I <sub>DD2</sub>		2.11	3.16		2.26	3.39		3.83	5.74		
	I <sub>DD1</sub>		0.24	0.36		0.27	0.41		0.61	0.91	mA	3.3V <sub>DC</sub>
	I <sub>DD2</sub>		2.04	3.06		2.13	3.20		3.12	4.68		
$\pi$ 141M6x	I <sub>DD1</sub>		0.77	1.16		0.87	1.30		1.78	2.67	mA	5V <sub>DC</sub>
	I <sub>DD2</sub>		1.60	2.41		1.73	2.60		3.03	4.55		
	I <sub>DD1</sub>		0.67	1.01		0.73	1.09		1.30	1.95	mA	3.3V <sub>DC</sub>
	I <sub>DD2</sub>		1.52	2.28		1.61	2.41		2.45	3.67		
$\pi$ 142M6x	I <sub>DD1</sub>		1.12	1.68		1.32	1.98		2.46	3.69	mA	5V <sub>DC</sub>
	I <sub>DD2</sub>		1.12	1.68		1.32	1.98		2.46	3.69		
	I <sub>DD1</sub>		1.08	1.62		1.18	1.77		1.90	2.85	mA	3.3V <sub>DC</sub>
	I <sub>DD2</sub>		1.08	1.62		1.18	1.77		1.90	2.85		

## INSULATION AND SAFETY RELATED SPECIFICATIONS

Table 13.Insulation Specifications

Parameter	Symbol	Value		Unit	Test Conditions/Comments
		$\pi$ 14xM3x	$\pi$ 14xM6x		
Rated Dielectric Insulation Voltage		3000	5000	V rms	1-minute duration
Minimum External Air Gap (Clearance)	L (CLR)	≥4	≥8	mm	Measured from input terminals to output terminals, shortest distance through air
Minimum External Tracking (Creepage)	L (CRP)	≥4	≥8	mm	Measured from input terminals to output terminals, shortest distance path along body
Minimum Internal Gap (Internal Clearance)		≥11	≥21	μm	Insulation distance through insulation
Tracking Resistance (Comparative Tracking Index)	CTI	>400	>400	V	DIN EN 60112 (VDE 0303-11):2010-05



Parameter	Symbol	Value		Unit	Test Conditions/Comments
		$\pi$ 14xM3x	$\pi$ 14xM6x		
Material Group		II	II		IEC 60112:2003 + A1:2009

## PACKAGE CHARACTERISTICS

Table 14.Package Characteristics

Parameter	Symbol	Typical Value		Unit	Test Conditions/Comments
		$\pi$ 14xM3x	$\pi$ 14xM6x		
Resistance (Input to Output) <sup>1</sup>	R <sub>IO</sub>	10 <sup>11</sup>	10 <sup>11</sup>	$\Omega$	
Capacitance (Input to Output) <sup>1</sup>	C <sub>IO</sub>	1.5	1.5	pF	@1MHz
Input Capacitance <sup>2</sup>	C <sub>I</sub>	3	3	pF	@1MHz
IC Junction to Ambient Thermal Resistance	$\theta_{JA}$	100	45	$^{\circ}\text{C}/\text{W}$	Thermocouple located at center of package underside

Notes:

<sup>1</sup>The device is considered a 2-terminal device; Short-circuit all terminals on the VDD1 side as one terminal, and short-circuit all terminals on the VDD2 side as the other terminal.

<sup>2</sup>Testing from the input signal pin to ground.

## REGULATORY INFORMATION

See Table 15 for details regarding recommended maximum working voltages for specific cross isolation waveforms and insulation levels.

Table 15.Regulatory

Regulatory	$\pi$ 14xM3x	$\pi$ 14xM6x
UL	Recognized under UL 1577 Component Recognition Program <sup>1</sup> Single Protection, 3000 V rms Isolation Voltage File (E494497)	Recognized under UL 1577 Component Recognition Program <sup>1</sup> Single Protection, 5000 V rms Isolation Voltage File (E494497)
VDE	DIN VDE V 0884-11:2017-01 <sup>2</sup> Basic insulation, V <sub>IORM</sub> = 565V peak, V <sub>IOSM</sub> = 3615 V peak File (40053041)	DIN VDE V 0884-11:2017-01 <sup>2</sup> Basic insulation, V <sub>IORM</sub> = 1200 V peak, V <sub>IOSM</sub> = 5000 V peak File (40052896)
CQC	Certified under CQC11-471543-2012 and GB4943.1-2011 Basic insulation at 500 V rms (707 V peak) working voltage Reinforced insulation at 250 V rms (353 V peak) NB SOIC-16 File (CQC20001260212) SSOP16 File (CQC20001260213)	Certified under CQC11-471543-2012 and GB4943.1-2011 Basic insulation at 845V rms (1200V peak) working voltage Reinforced insulation at 422V rms (600V peak) WB SOIC-16 File (CQC20001260258)

Notes:

<sup>1</sup>In accordance with UL 1577, each  $\pi$ 140M3x/ $\pi$ 141M3x/ $\pi$ 142M3x is proof tested by applying an insulation test voltage  $\geq$  3600 V rms for 1 sec; each  $\pi$ 140M6x/ $\pi$ 141M6x/ $\pi$ 142M6x is proof tested by applying an insulation test voltage  $\geq$  6000 V rms for 1 sec

<sup>2</sup>In accordance with DIN VDE V 0884-11, each  $\pi$ 140M3x/ $\pi$ 141M3x/ $\pi$ 142M3x is proof tested by applying an insulation test voltage  $\geq$  848 V peak for 1 sec (partial discharge detection limit = 5 pC); each  $\pi$ 140M6x/ $\pi$ 141M6x/ $\pi$ 142M6x is proof tested by  $\geq$  1800V peak for 1 sec.

## DIN VDE V 0884-11 (VDE V 0884-11) INSULATION CHARACTERISTICS

Table 16.VDE Insulation Characteristics

Description	Test Conditions/Comments	Symbol	Characteristic		Unit
			$\pi$ 14xM3x	$\pi$ 14xM6x	
Installation Classification per DIN VDE 0110 For Rated Mains Voltage $\leq$ 150 V rms For Rated Mains Voltage $\leq$ 300 V rms For Rated Mains Voltage $\leq$ 400 V rms			I to IV I to III I to III	I to IV I to III I to III	
Climatic Classification			40/105/21	40/105/21	
Pollution Degree per DIN VDE 0110, Table 1			2	2	
Maximum repetitive peak isolation voltage		V <sub>IORM</sub>	565	1200	V peak

Description	Test Conditions/Comments	Symbol	Characteristic		Unit
			$\pi 14xM3x$	$\pi 14xM6x$	
Input to Output Test Voltage, Method B1	$V_{IORM} \times 1.5 = V_{pd(m)}$ , 100% production test, $t_{ini} = t_m = 1$ sec, partial discharge < 5 pC	$V_{pd(m)}$	848	1800	V peak
Input to Output Test Voltage, Method A After Environmental Tests Subgroup 1 After Input and/or Safety Test Subgroup 2 and Subgroup 3	$V_{IORM} \times 1.2 = V_{pd(m)}$ , $t_{ini} = 60$ sec, $t_m = 10$ sec, partial discharge < 5 pC	$V_{pd(m)}$	678	1440	V peak
	$V_{IORM} \times 1.2 = V_{pd(m)}$ , $t_{ini} = 60$ sec, $t_m = 10$ sec, partial discharge < 5 pC		678	1440	V peak
Highest Allowable Overvoltage		$V_{IOTM}$	4200	7071	V peak
Surge Isolation Voltage Basic	Basic insulation, 1.2/50 $\mu$ s combination wave, $V_{TEST} = 1.3 \times V_{IOSM}$ (qualification) <sup>1</sup>	$V_{IOSM}$	3615	5000	V peak
Safety Limiting Values	Maximum value allowed in the event of a failure (see Figure 6)				
Maximum Safety Temperature		$T_S$	150	150	$^{\circ}C$
Maximum Power Dissipation at 25 $^{\circ}C$		$P_S$	1.67	2.78	W
Insulation Resistance at $T_S$	$V_{IO} = 500$ V	$R_S$	>10 <sup>9</sup>	>10 <sup>9</sup>	$\Omega$

Notes:

<sup>1</sup>In accordance with DIN V VDE V 0884-11,  $\pi 1xxx3x$  is proof tested by applying a surge isolation voltage 4700 V,  $\pi 1xxx6x$  is proof tested by applying a surge isolation voltage 6500 V.

Typical Thermal Characteristic

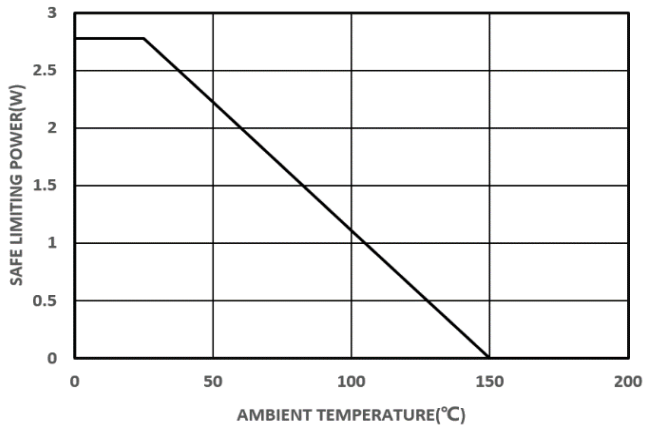
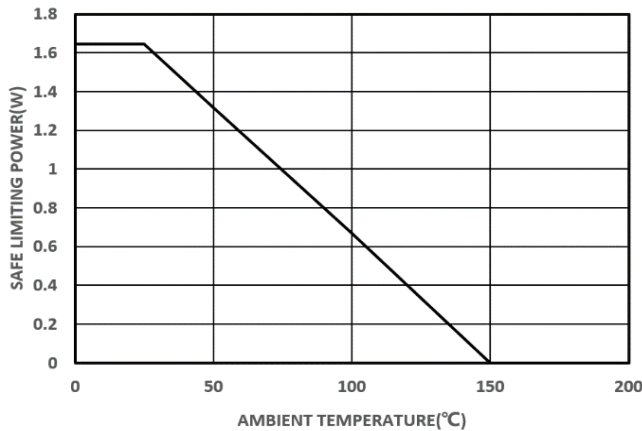

Figure 6. Thermal Derating Curve, Dependence of Safety Limiting Values with Ambient Temperature per VDE (left:  $\pi 14xM3x$ ; right:  $\pi 14xM6x$ )

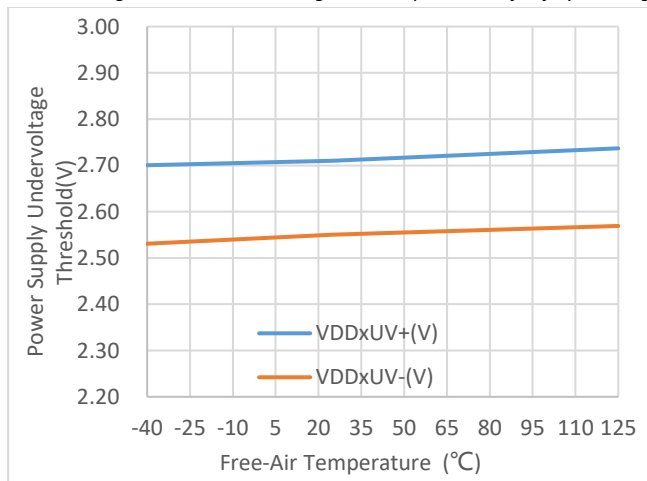

Figure 7. UVLO vs. Free-Air Temperature

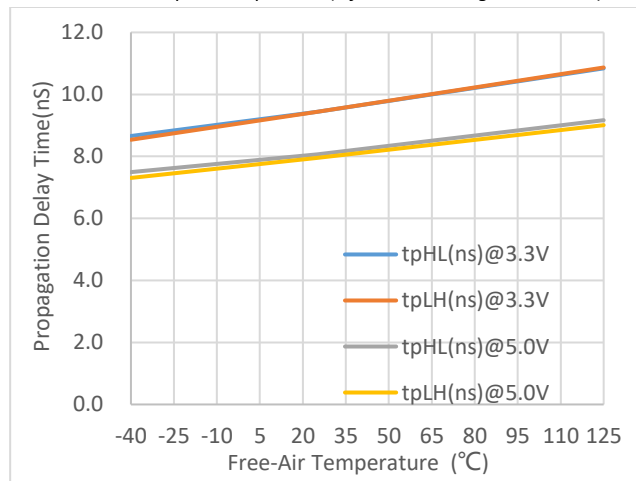

Figure 8.  $\pi 14xM3x$  Propagation Delay Time vs. Free-Air Temperature

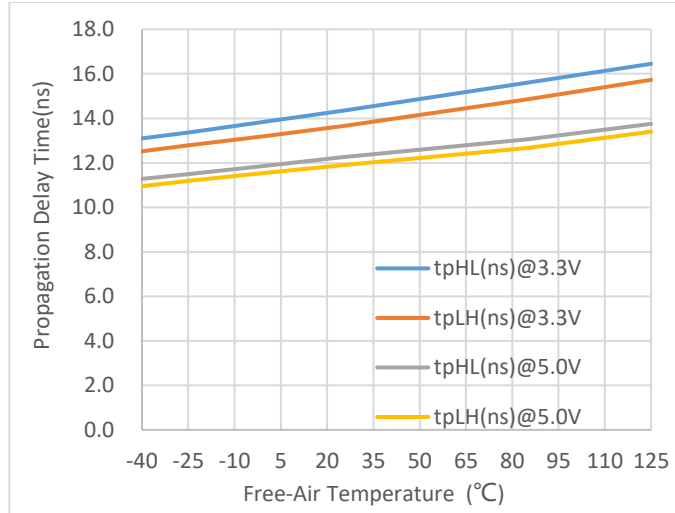

Figure 9.  $\pi$ 14xM6x Propagation Delay Time vs. Free-Air Temperature

Timing test information

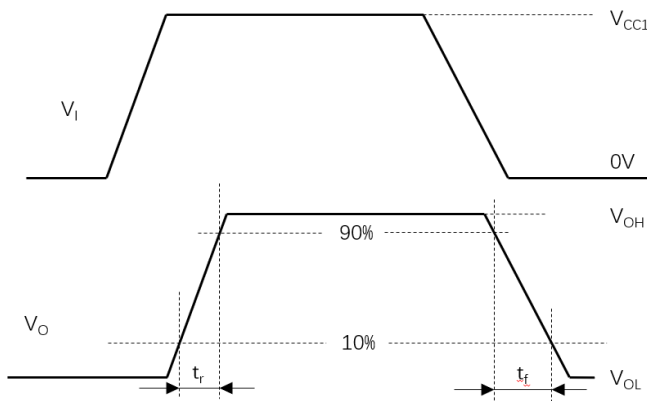

Figure 10. Transition time waveform measurement

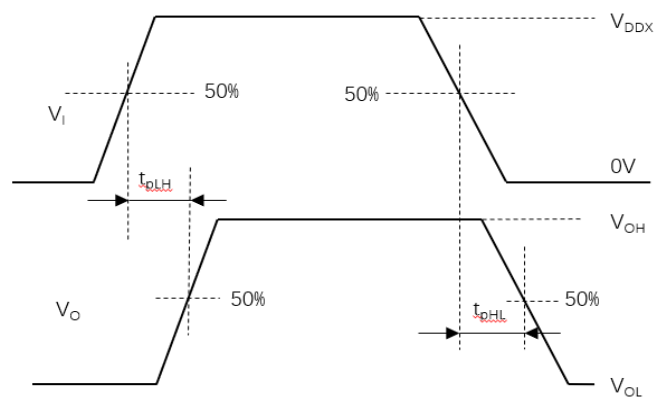

Figure 11. Propagation delay time waveform measurement

## APPLICATIONS INFORMATION

### OVERVIEW

The  $\pi 1xxxx$  are 2PaiSemi digital isolators product family based on 2PaiSEMI unique **iDivider**® technology. Intelligent voltage **Divider** technology (**iDivider**® technology) is a new generation digital isolator technology invented by 2PaiSEMI. It uses the principle of capacitor voltage divider to transmit signal directly cross the isolator capacitor without signal modulation and demodulation. Compare to the traditional Opto-couple technology, icoupler technology, OOK technology, **iDivider**® is a more essential and concise isolation signal transmit technology which leads to greatly simplification on circuit design and therefore significantly improves device performance, such as lower power consumption, faster speed, enhanced anti-interference ability, lower noise.

By using matured standard semiconductor CMOS technology and the innovative **iDivider**® design, these isolation components provide outstanding performance characteristics and reliability superior to alternatives such as optocoupler devices and other integrated isolators. The  $\pi 1xxxx$  isolator data channels are independent and are available in a variety of configurations with a withstand voltage rating of 1.5 kV rms to 5.0 kV rms and the data rate from DC up to 600Mbps (see the Ordering Guide).

The  $\pi 14xMxx$  are the outstanding 10Mbps quad-channel digital isolators with the enhanced ESD capability. the devices transmit data across an isolation barrier by layers of silicon dioxide isolation.

The devices operate with the supply voltage on either side ranging from 3.0 V to 5.5 V, offering voltage translation of 3.3 V, and 5 V logic. The  $\pi 14xMxx$  have very low propagation delay and high speed. The input/output design techniques allow logic and supply voltages over a wide range from 3.0 V to 5.5 V, offering voltage translation of 3.3 V and 5 V logic. The architecture is designed for high common-mode transient immunity and high immunity to electrical noise and magnetic interference.

See the Ordering Guide for the model numbers that have the fail-safe output state of low or high.

### PCB LAYOUT

The low-ESR ceramic bypass capacitors must be connected between  $V_{DD1}$  and  $GND_1$  and between  $V_{DD2}$  and  $GND_2$ . The bypass capacitors are placed on the PCB as close to the isolator device as possible. The recommended bypass capacitor value is between 0.1  $\mu F$  and 10  $\mu F$ . The user may also include resistors (50–300  $\Omega$ ) in series with the inputs and outputs if the system is excessively noisy, or in order to enhance the anti ESD ability of the system.

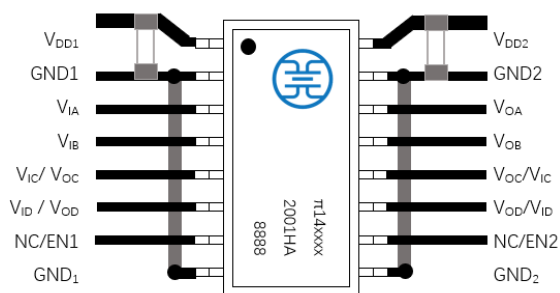

Figure 12. Recommended Printed Circuit Board Layout

Avoid reducing the isolation capability, Keep the space underneath the isolator device free from metal such as planes, pads, traces and vias.

To minimize the impedance of the signal return loop, keep the solid ground plane directly underneath the high-speed signal path, the closer the better. The return path will couple between the nearest ground plane to the signal path. Keep suitable trace width for controlled impedance transmission lines interconnect.

To reduce the rise time degradation, keep the length of input/output signal traces as short as possible, and route low inductance loop for the signal path and its return path.

### JITTER MEASUREMENT

The eye diagram shown in the figure below provides the jitter measurement result for the  $\pi 14xMxx$ . The Keysight 81160A pulse function arbitrary generator works as the data source for the  $\pi 14xMxx$ , which generates 10Mbps pseudo random bit sequence (PRBS). The Keysight DSOS104A digital storage oscilloscope captures the  $\pi 14xMxx$  output waveform and recovers the eye diagram with the SDA tools and eye diagram analysis tools. The result shows a typical measurement jitter data.

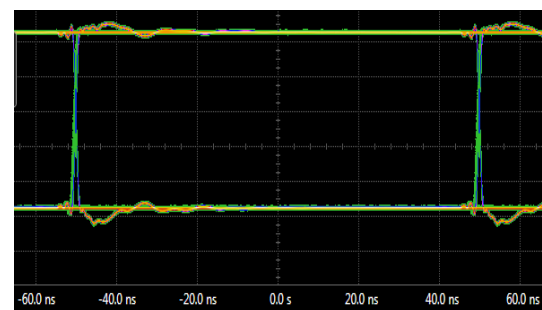

Figure 13.  $\pi 14xMxx$  Eye Diagram

### CMTI MEASUREMENT

To measure the Common-Mode Transient Immunity (CMTI) of  $\pi 1xxxx$  isolator under specified common-mode pulse magnitude (VCM) and specified slew rate of the common-mode pulse (dVCM/dt) and other specified test or ambient conditions, The common-mode pulse generator (G1) will be capable of providing fast rise and fall pulses of specified magnitude and duration of the common-mode pulse (VCM), such that the maximum common-mode slew rates (dVCM/dt) can be applied to  $\pi 1xxxx$  isolator coupler under measurement. The common-mode pulse is applied between one side ground  $GND_1$  and the other side ground  $GND_2$  of  $\pi 1xxxx$  isolator, and shall be capable of providing positive transients as well as negative transients.

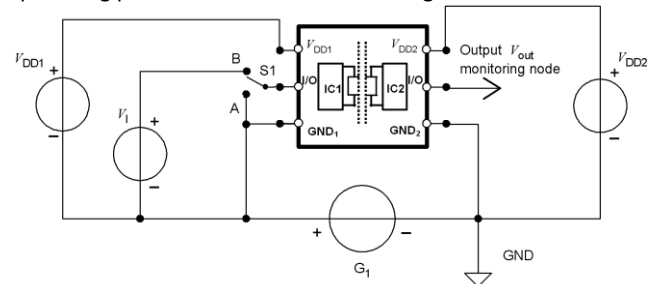

Figure 14. Common-mode transient immunity (CMTI) measurement

OUTLINE DIMENSIONS

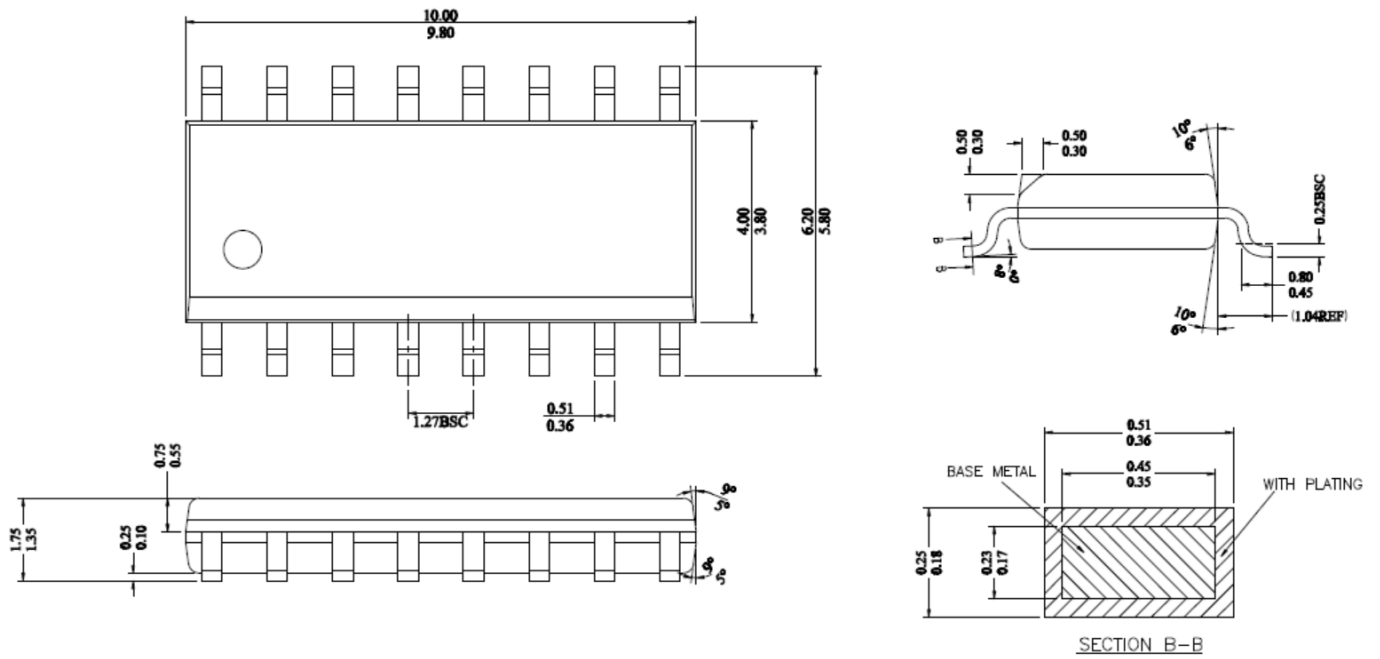

Figure 15.16-Lead Narrow body SOIC Package [NB SOIC-16] –dimension unit(mm)

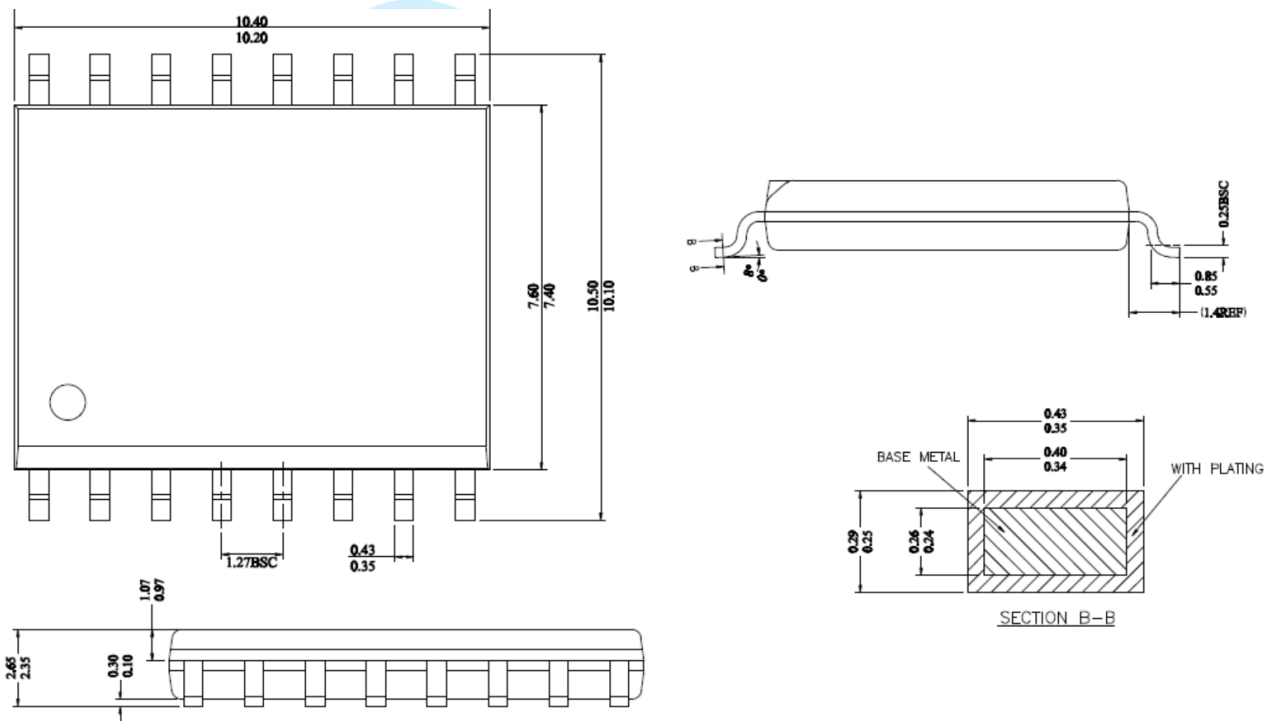
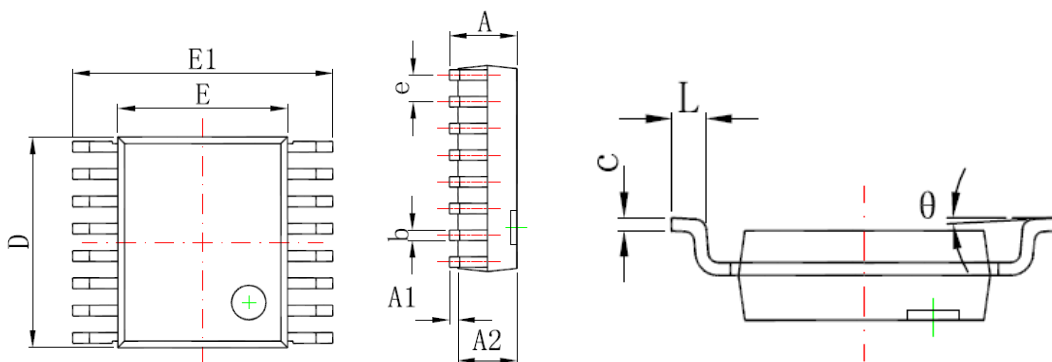

Figure 16.16-Lead Wide Body Outline Package [WB SOIC-16] –dimension unit(mm)



Symbol	Dimensions In Millimeters		Dimensions In Inches	
	Min	Max	Min	Max
A	1.350	1.750	0.053	0.069
A1	0.100	0.250	0.004	0.010
A2	1.350	1.550	0.053	0.061
b	0.200	0.300	0.008	0.012
c	0.170	0.250	0.007	0.010
D	4.700	5.100	0.185	0.200
E	3.800	4.000	0.150	0.157
E1	5.800	6.200	0.228	0.244
e	0.635(BSC)		0.025(BSC)	
L	0.400	1.270	0.016	0.050
$\theta$	0°	8°	0°	8°

Figure 17.16-Lead SSOP Outline Package [SSOP-16]

## Land Patterns

16-Lead Narrow Body SOIC [NB SOIC-16]

The Figure below illustrates the recommended land pattern details for the  $\pi$ 1xxxx in a 16-pin narrow-body SOIC. The table below lists the values for the dimensions shown in the illustration.

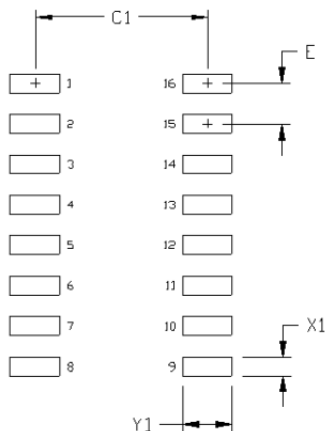

Figure 18.16-Lead Narrow Body SOIC [NB SOIC-16] Land Pattern

Table 17. 16-Lead Narrow Body SOIC [NB SOIC-16] Land Pattern Dimensions

Dimension	Feature	Parameter	Unit
C1	Pad column spacing	5.40	mm
E	Pad row pitch	1.27	mm
X1	Pad width	0.60	mm
Y1	Pad length	1.55	mm

Note:

1.This land pattern design is based on IPC -7351

2.All feature sizes shown are at maximum material condition and a card fabrication tolerance of 0.05 mm is assumed.

16-Lead wide Body SOIC [WB SOIC-16]

The figure below illustrates the recommended land pattern details for the  $\pi$ 1xxxxx in a 16-pin wide-body SOIC package. The table lists the values for the dimensions shown in the illustration.

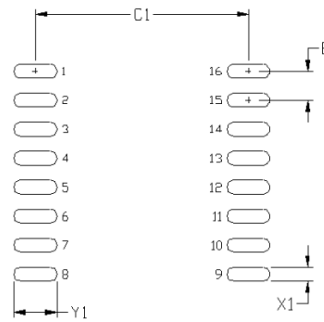

Figure 19.16-Lead Wide Body SOIC [WB SOIC-16] Land Pattern

Table 18. 16-Lead Wide Body SOIC Land Pattern Dimensions

Dimension	Feature	Parameter	Unit
C1	Pad column spacing	9.40	mm
E	Pad row pitch	1.27	mm
X1	Pad width	0.60	mm
Y1	Pad length	1.90	mm

Note:

- 1.This land pattern design is based on IPC -7351
- 2.All feature sizes shown are at maximum material condition and a card fabrication tolerance of 0.05 mm is assumed.

16-Lead SSOP

The figure below illustrates the recommended land pattern details for the  $\pi$ 1xxxxx in a 16-Lead SSOP package. The table lists the values for the dimensions shown in the illustration.

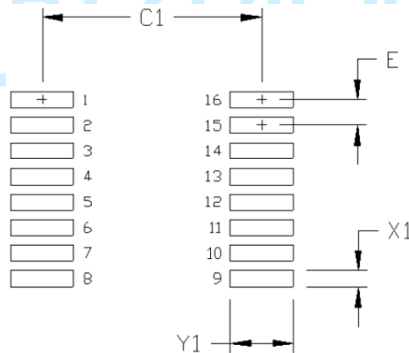

Figure 20. 16-Lead SSOP Land Pattern

Table 19. 16-Lead SSOP Land Pattern Dimensions

Dimension	Feature	Parameter	Unit
C1	Pad column spacing	5.40	mm
E	Pad row pitch	0.635	mm
X1	Pad width	0.40	mm
Y1	Pad length	1.55	mm

Note:

- 1.This land pattern design is based on IPC -7351
- 2.All feature sizes shown are at maximum material condition and a card fabrication tolerance of 0.05 mm is assumed.

### Top Marking

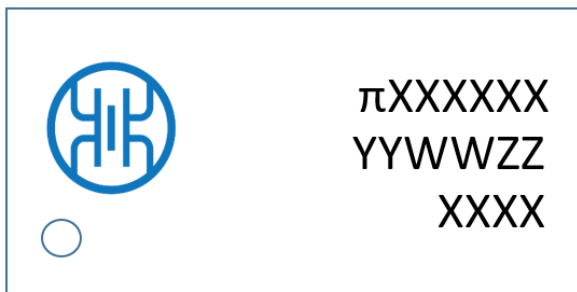

Line 1	$\pi$ XXXXXX=Product name
Line 2	YY = Work Year WW = Work Week ZZ=Manufacturing code from assembly house
Line 3	XXXX, no special meaning

Figure 21. Top Marking

### REEL INFORMATION

16-Lead Narrow Body SOIC [NB SOIC-16]

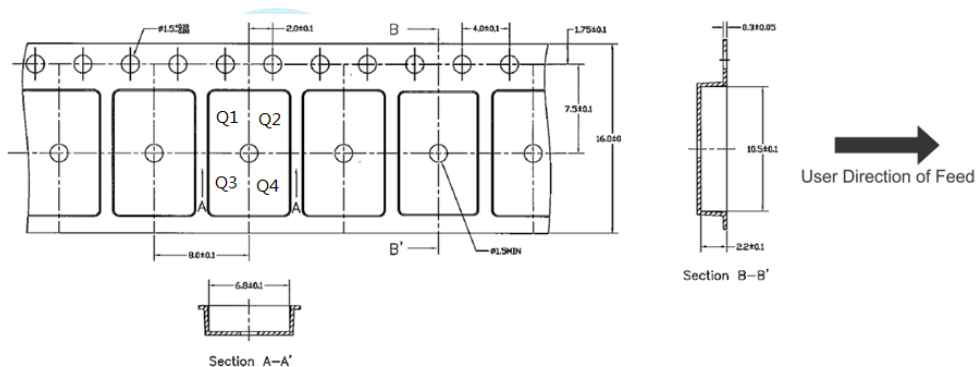

Note: The Pin 1 of the chip is in the quadrant Q1

Figure 22.16-Lead Narrow Body SOIC [NB SOIC-16] Reel Information—dimension unit(mm)

16-Lead Wide Body SOIC [WB SOIC-16]

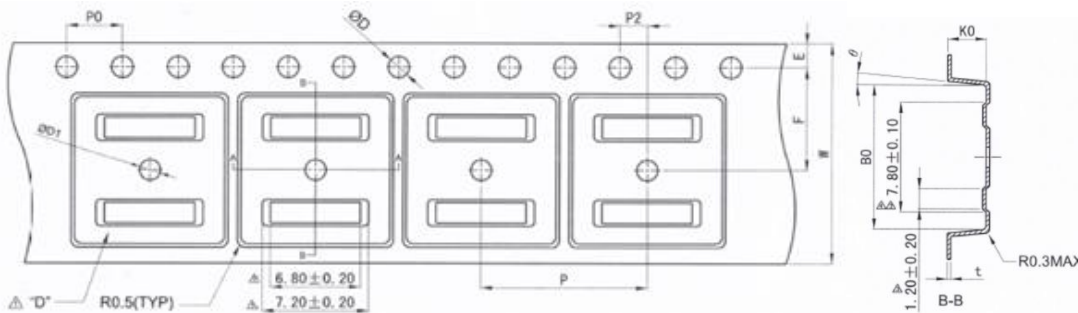



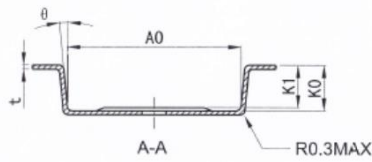

Items	Size(mm)	Items	Size(mm)
E	1.75±0.10	W	16.00±0.30
F	7.50±0.05	P	12.00±0.10
P2	2.00±0.05	A0	10.90±0.10
D	1.55±0.05	B0	10.80±0.10
D1	1.5±0.10	K0	3.00±0.10
P0	4.00±0.10	t	0.30±0.05
10P0	40.00±0.20	K1	2.70±0.10
		$\theta$	5° TYP

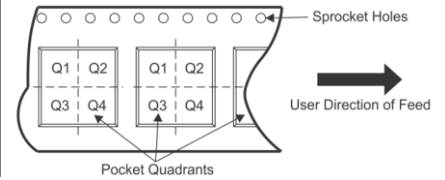

Note: The Pin 1 of the chip is in the quadrant Q1  
Figure 23.16-Lead Wide Body SOIC [WB SOIC-16] Reel Information

16-Lead SSOP

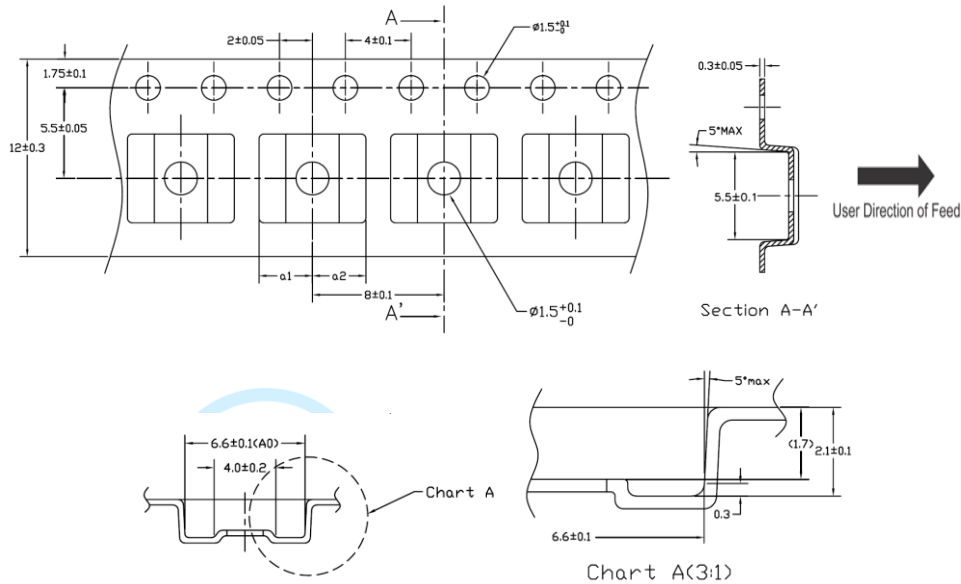

Figure 24. 16-Lead SSOP [SSOP-16] Reel Information—dimension unit(mm)

## ORDERING GUIDE

Table 20. Ordering guide

Model Name <sup>1</sup>	Temperature Range	No. of Inputs, V <sub>DD1</sub> Side	No. of Inputs, V <sub>DD2</sub> Side	Isolation Rating (kV rms)	Fail-Safe Output State	Package	MSL Peak Temp <sup>2</sup>	MOQ/Quantity per reel <sup>3</sup>
$\pi$ 140M31	-40 to 125°C	4	0	3	High	NB SOIC-16	Level-3-260C-168 HR	2500
$\pi$ 140M30	-40 to 125°C	4	0	3	Low	NB SOIC-16	Level-3-260C-168 HR	2500
$\pi$ 141M31	-40 to 125°C	3	1	3	High	NB SOIC-16	Level-3-260C-168 HR	2500
$\pi$ 141M30	-40 to 125°C	3	1	3	Low	NB SOIC-16	Level-3-260C-168 HR	2500
$\pi$ 142M31	-40 to 125°C	2	2	3	High	NB SOIC-16	Level-3-260C-168 HR	2500
$\pi$ 142M30	-40 to 125°C	2	2	3	Low	NB SOIC-16	Level-3-260C-168 HR	2500
$\pi$ 140M61	-40 to 125°C	4	0	5	High	WB SOIC-16	Level-3-260C-168 HR	1500
$\pi$ 140M60	-40 to 125°C	4	0	5	Low	WB SOIC-16	Level-3-260C-168 HR	1500
$\pi$ 141M61	-40 to 125°C	3	1	5	High	WB SOIC-16	Level-3-260C-168 HR	1500
$\pi$ 141M60	-40 to 125°C	3	1	5	Low	WB SOIC-16	Level-3-260C-168 HR	1500
$\pi$ 142M61	-40 to 125°C	2	2	5	High	WB SOIC-16	Level-3-260C-168 HR	1500
$\pi$ 142M60	-40 to 125°C	2	2	5	Low	WB SOIC-16	Level-3-260C-168 HR	1500
$\pi$ 140M31S	-40 to 125°C	4	0	3	High	16-Lead SSOP	Level-3-260C-168 HR	4000
$\pi$ 140M30S	-40 to 125°C	4	0	3	Low	16-Lead SSOP	Level-3-260C-168 HR	4000
$\pi$ 141M31S	-40 to 125°C	3	1	3	High	16-Lead SSOP	Level-3-260C-168 HR	4000
$\pi$ 141M30S	-40 to 125°C	3	1	3	Low	16-Lead SSOP	Level-3-260C-168 HR	4000
$\pi$ 142M31S	-40 to 125°C	2	2	3	High	16-Lead SSOP	Level-3-260C-168 HR	4000
$\pi$ 142M30S	-40 to 125°C	2	2	3	Low	16-Lead SSOP	Level-3-260C-168 HR	4000

<sup>1</sup>  $\pi$ 14xxxxx is equals to  $\pi$ 1xxxxx in the customer BOM.

<sup>2</sup> MSL, Peak Temp. - The Moisture Sensitivity Level rating according to the JEDEC industry standard classifications, and peak solder temperature.

<sup>3</sup> MOQ, minimum ordering quantity.

**PART NUMBER NAMED RULE**

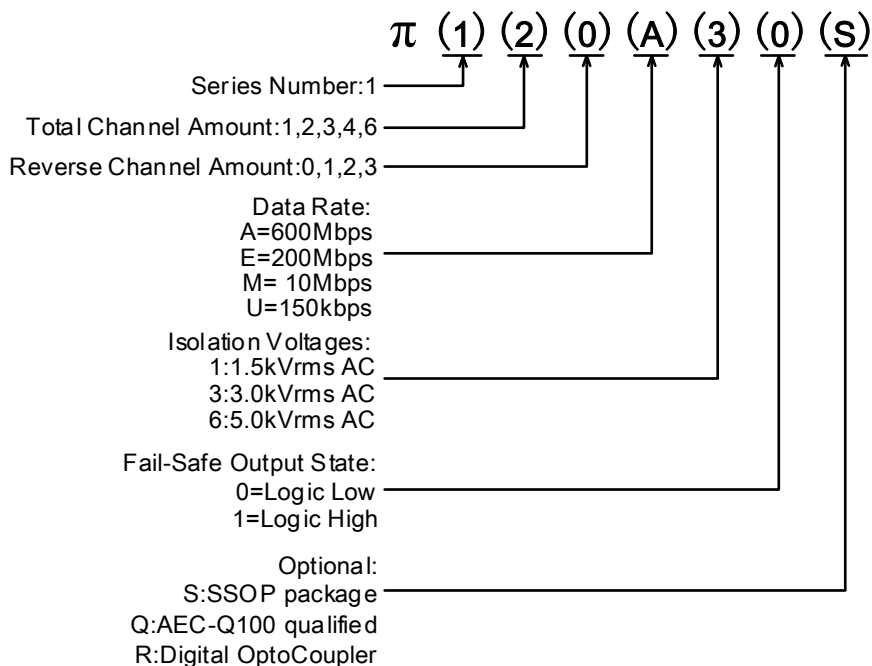

Notes:  
 Pai1xxxx is equals to  $\pi$ 1xxxx in the customer BOM

Figure 25. Part number named rule

**IMPORTANT NOTICE AND DISCLAIMER**

2Pai semi intends to provide customers with the latest, accurate, and in-depth documentation. However, no responsibility is assumed by 2Pai semi for its use, nor for any infringements of patents or other rights of third parties that may result from its use. Characterization data, available modules, and "Typical" parameters provided can and do vary in different applications. Application examples described herein are for illustrative purposes only. 2Pai semi reserves the right to make changes without further notice and limitation to product information, specifications, and descriptions herein, and does not give warranties as to the accuracy or completeness of the included information. 2Pai semi shall have no liability for the consequences of use of the information supplied herein.

Trademarks and registered trademarks are the property of their respective owners. This document does not imply, or express copyright licenses granted hereunder to design or fabricate any integrated circuits.

Room 307-309, No.22, Boxia Road, Pudong New District, Shanghai, 201203, China 021-50850681

2Pai Semiconductor Co., Limited. All rights reserved.

<http://www.rpsemi.com/>

## REVISION HISTORY

Revision	Date	Page	Change Record
1.0	2018/09/17	All	Initial version
1.1	2018/11/28	P11	Changed the recommended bypass capacitor value.
1.2	2019/09/08	Page1	Changed the contact address. Add <i>iDivider</i> technology description in General Description. Changed propagation delay time, CMTI and HBM ESD. Added WB SOIC-16 Lead information.
1.3	2019/12/20	Page1,11,14	Changed description of $\pi$ 1xxx6x.
1.4	2020/02/16	Page1	Changed propagation delay time.
1.5	2020/02/25	Page5	Changed Pulse Width Distortion.
1.6	2020/03/16	Page6	Changed VDDx Undervoltage Threshold and Regulatory Information. Added information of Land Patterns and Top Marking
1.7	2020/04/16	Page12	Optimize description and format to make it consistent with the Chinese version.
1.8	2021/05/17	Page 1,5~10	Changed Regulatory Information. Added propagation delay time and supply current of $\pi$ 1xxM6x.

