



# Disea Electronics Co., LTD

E-mail:mkt@diseaelec.com

URL:www.diseaelec.com

ADD: A1 Building, Electronic Information Industry Park, Keji 1st Road, Dinghu district, Zhaoqing city, Guangdong Province,China

## PRODUCT SPECIFICATIONS

For Customer: \_\_\_\_\_

: APPROVAL FOR SPECIFICATION

Customer Model No. \_\_\_\_\_

: APPROVAL FOR SAMPLE

Module No.: ZW-T101QIHA-39CP

Date : 2023-2-11

### Table of Contents

No.	Item	Page
1	Cover Sheet(Table of Contents)	P1
2	Revision Record	P2
3	General Specifications	P3
4	Outline Drawing	P4
5	Absolute Maximum Ratings	P5
6	Electrical Specifications	P6-P8
7	Optical Characteristics	P9-P12
8	Reliability Test Items and Criteria	P13
9	Precautions for Use of LCD Modules	P14-P15
10	Picture for LCD Module	P15-P16
11	Package Specifications	P17

### For Customer's Acceptance:

Approved By	Comment

PREPARED	CHECKED	VERIFIED BY QA DEPT	VERIFIED BY R&D DEPT
YGM			

## 2. Revision Record

Date	Rev.No.	Page	Revision Items	Prepared
2023.2.11	V0		The first release	YGM

### 3. General Specifications

ZW-T101QIHA-39CP is a TFT-LCD module. It is composed of a TFT-LCD panel, driver IC, FPC, a back light unit and PCB matherboard. The 10.1'' display area contains 1280X(RGB)X800 pixels and can display up to 16.7M colors. This product accords with ROHS environmental criterion.

Item	Contents	Unit	Note
LCD Type	TFT	-	
Display color	16.7M		1
Viewing Direction	ALL	O'Clock	
Gray scale inversion direction	FREE	O'Clock	
Module size	240.00X163.5X5.0 (exclude PCBA)	mm	2
Number of Dots	1280×800	dots	
Controller for LCD	--	-	
Driver for CTP	ILI2511	-	
Power Supply Voltage	12V(PCBA) / 5V(HDMI)/5V(USB CTP)	V	
Backlight	3S14P-LEDs (white)	pcs	
Weight	390	g	
Interface	HDMI for LCM and USB for CTP	-	

## 4.Outline.Drawing

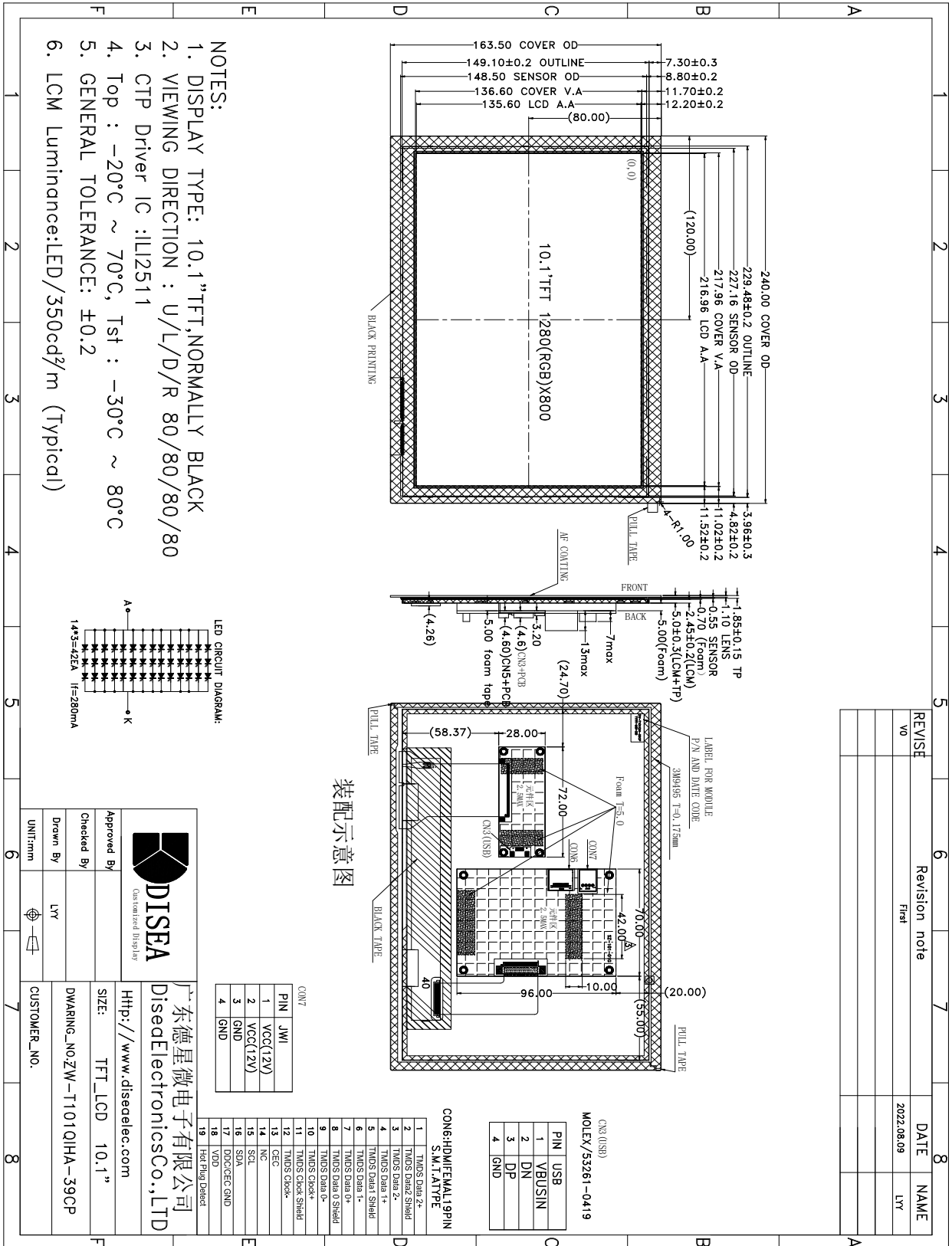

REVISE	Revision note	DATE	NAME
V0	First	2022.08.09	LYY

Approved By: \_\_\_\_\_
   
 Checked By: \_\_\_\_\_
   
 Drawn By: LYJ
   
 UNIT:mm

[Http://www.diseaelec.com](http://www.diseaelec.com)
  
 SIZE: TFT\_LCD 10.1"
   
 DWARING\_NO: ZW-T1101QIHA-39CP
   
 CUSTOMER\_NO.

**广东德星微电子有限公司**
  
**Disea Electronics Co., LTD**

## 5. Absolute Maximum Ratings(Ta=25°C)

### 5.1 Electrical Absolute Maximum Ratings.(Vss=0V ,Ta=25°C)

Item	Symbol	Min.	Max.	Unit	Note
Power Supply Voltage	VDD	-0.3	6.0	V	1, 2
Power Supply Voltage	VCC	-0.3	13.0	V	1, 2
Power Supply Voltage	VBUSIN	-0.3	6.0	V	1, 2

Notes:

1. If the module is above these absolute maximum ratings. It may become permanently damaged. Using the module within the following electrical characteristic conditions are also exceeded, the module will malfunction and cause poor reliability.
2.  $V_{CC} > V_{SS}$  must be maintained.
3. Please be sure users are grounded when handing LCD Module.

### 5.2 Environmental Absolute Maximum Ratings.

Item	Storage		Operating		Note
	MIN.	MAX.	MIN.	MAX.	
Ambient Temperature	-30°C	80°C	-20°C	70°C	1,2
Humidity	-	-	-	-	3

1. The response time will become lower when operated at low temperature.
2. Background color changes slightly depending on ambient temperature.

The phenomenon is reversible.

3.  $T_a \leq 40^\circ\text{C}$  :85%RH MAX.

$T_a > 40^\circ\text{C}$  :Absolute humidity must be lower than the humidity of 85%RH at 40°C.

## 6. Electrical Specifications

### 6.1 Electrical characteristics(V<sub>SS</sub>=0V ,T<sub>a</sub>=25°C)

Parameter	Symbol	Condition	Min	Typ	Max	Unit	Note
Power supply	VDD(HDMI)	T <sub>a</sub> =25°C	4.5	5.0	5.5	V	
Power supply	VBUSIN(CTP)	T <sub>a</sub> =25°C	4.5	5.0	5.5	V	
Power supply	VCC(PCBA)	T <sub>a</sub> =25°C	11.5	12	12.5	V	
Current for LCM	I <sub>CC</sub>	T <sub>a</sub> =25°C VCC=12V		600	650	mA	
Input voltage	'H'	V <sub>IH</sub>	V <sub>DD</sub> (HDMI)=5.0V	0.8V <sub>DD</sub>	-	V <sub>DD</sub>	V
	'L'	V <sub>IL</sub>	V <sub>DD</sub> (HDMI)=5.0V	0	-	0.2V <sub>DD</sub>	V

### 6.2 LED backlight specification(V<sub>SS</sub>=0V ,T<sub>a</sub>=25°C)

Item	Symbol	Condition	Min	Typ	Max	Unit	Note
Supply voltage	V <sub>f</sub>	I <sub>f</sub> =280mA	8.1	9.0	9.9	V	
Uniformity	ΔBp	I <sub>f</sub> =280mA	75	80	-	%	
Life Time	time	I <sub>f</sub> =280mA	20K	-		hours	1

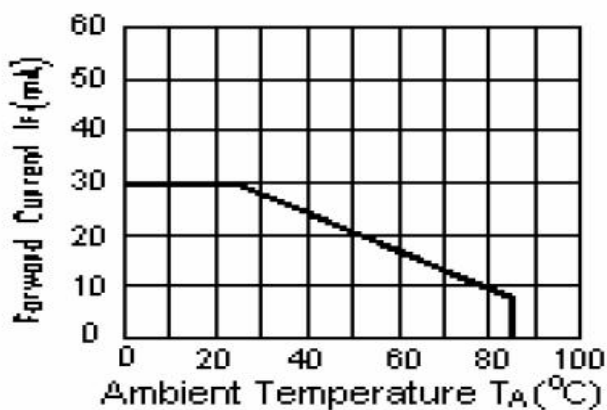

Note 1: Brightness to be decreased to 50% of the initial value at ambient temperature T<sub>A</sub>=25

## 6.3 Interface signals

### CON6 (HDMI FEMAL 19PIN S.M.T A TYPE )

Pin No.	Symbol	I/O	Function
1	TMDS Data 2+	I	HDMI Data 2+
2	TMDS Data 2 Shield	I	HDMI Data 2 Shield
3	TMDS Data 2-	I	HDMI Data 2-
4	TMDS Data 1+	I	HDMI Data 1+
5	TMDS Data 1 Shield	I	HDMI Data 1 Shield
6	TMDS Data 1-	I	HDMI Data 1-
7	TMDS Data 0+	I	HDMI Data 0+
8	TMDS Data 0 Shield	I	HDMI Data 0 Shield
9	TMDS Data 0-	I	HDMI Data 0-
10	TMDS Clock+	I	HDMI Clock+
11	TMDS Clock Shield	I	HDMI Clock Shield
12	TMDS Clock-	I	HDMI Clock-
13	CEC	I	Consumer Electronics Control
14	NC	I	No Connection
15	SCL	I	Serial clock
16	SDA	I	Serial Input /output data bus
17	DDC/CEC GND	P	DDC/CEC Ground
18	VDD	P	Power Supply +5v
19	HPD	P	Hot Plug Detect

### CON7(PCBA)

Pin No.	Symbol	I/O	Function
1	VCC	P	Power supply(+12V)
2	VCC	P	Power supply(+12V)
3	GND	P	Ground.
4	GND	P	Ground.

**CTP PIN:**

Pin No.	Symbol	I/O	Function
1	VBUSIN	P	Power supply(+5)
2	DN	I	Data -
3	DP	I	Data+
4	GND	P	Ground.

**CTP Characteristics**

Item	Specification	Remarks
Outline Dimension	240.00×163.50	mm
Total Thickness	1.85	mm
View Area	217.96×136.60	mm
TP size	10.1	inch
Interface Type	USB	-
Operation Temperature	-20°C~+70°C, ≤90%RH	-
Storage Temperature	-30°C~+80°C, ≤90%RH	-
Glass Thickness	1.1	mm
Resolution	1280*800	Dots
Surface hardness	≥6H	-
Control IC	ILI2511	-
Touch Point	10	point
Reporting Rate	>100	Hz
Jitter	<1	mm
Transparency	≥85%	-
Connection Type	Connector(PCB)	-
Win8 Certified	YES	-



## 7. Optical Characteristics

Item	Symbol	Condition	Min.	Typ.	Max.	Unit	Note
Brightness	Bp	$\theta=0^\circ$	-	350	-	Cd/m <sup>2</sup>	1
Uniformity	$\Delta Bp$	$\Phi=0^\circ$	75	80	-	%	1,2
Viewing Angle	3:00	Cr $\geq$ 10	-	80	-	Deg	3
	6:00		-	80	-		
	9:00		-	80	-		
	12:00		-	80	-		
Contrast Ratio	Cr	$\theta=0^\circ$ $\Phi=0^\circ$	600	800	-	-	4
Response Time	T <sub>r</sub>		-	10	20	ms	5
	T <sub>f</sub>		-	15	30	ms	
Color of CIE Coordinate	W	x	Typ -0.05	0.31	Typ +0.05	-	1,6
		y		0.32		-	
	R	x		0.56		-	
		y		0.33		-	
	G	x		0.31		-	
		y		0.52		-	
	B	x		0.16		-	
		y		0.18		-	
NTSC Ratio	S	-	50	-	%		

Note: The parameter is slightly changed by temperature, driving voltage and material

Note 1: The data are measured after LEDs are turned on for 5 minutes. LCM displays full white. The brightness is the average value of 9 measured spots. Measurement equipment BM-7 ( $\Phi$ 5mm)

Measuring condition:

- Measuring surroundings: Dark room.
- Measuring temperature: Ta=25°C.
- Adjust operating voltage to get optimum contrast at the center of the display.

Measured value at the center point of LCD panel after more than 5 minutes while backlight turning on.

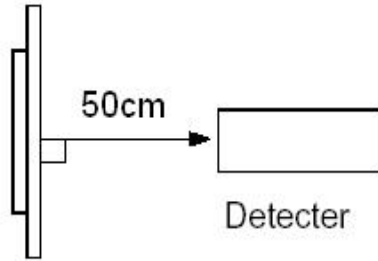

Note 2: The luminance uniformity is calculated by using following formula.

$$\Delta Bp = Bp (\text{Min.}) / Bp (\text{Max.}) \times 100 (\%)$$

$Bp (\text{Max.})$  = Maximum brightness in 9 measured spots

$Bp (\text{Min.})$  = Minimum brightness in 9 measured spots.

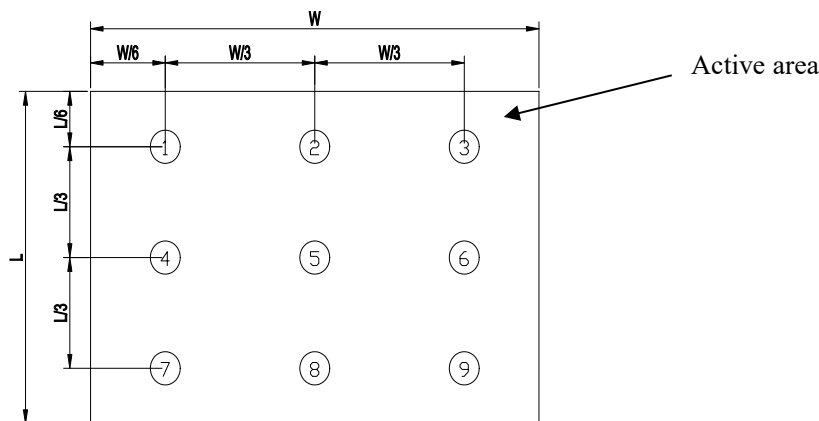

Note 3: The definition of viewing angle:

Refer to the graph below marked by  $\theta$  and  $\phi$

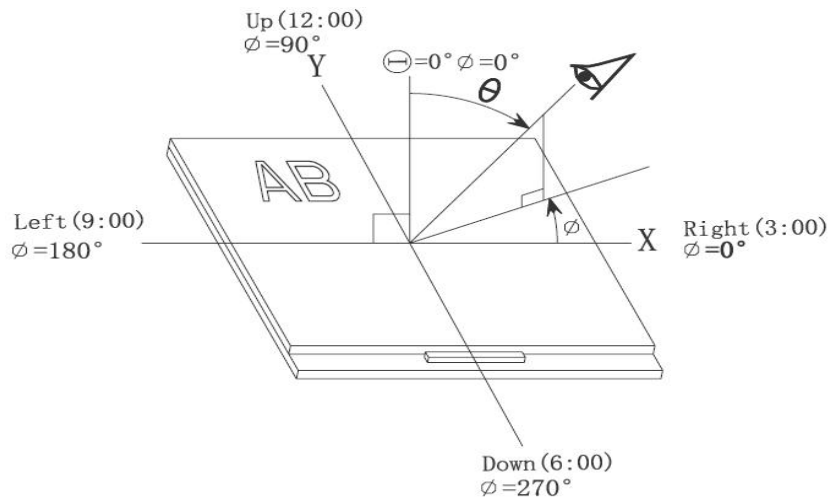

Note 4: Definition of contrast ratio.( Test LCD using DMS501)

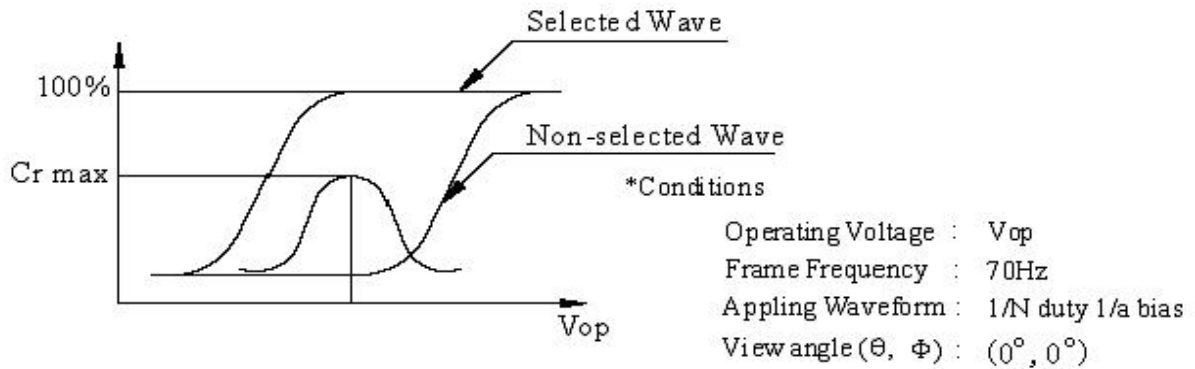

$$\text{Contrast ratio}(Cr) = \frac{\text{Brightness of selected dots}}{\text{Brightness of non-selected dots}}$$

Note 5: Definition of Response time. (Test LCD using DMS501):

The output signals of photo detector are measured when the input signals are changed from “black” to “white”(falling time) and from “white” to “black”(rising time), respectively. The response time is defined as the time interval between the 10% and 90% of amplitudes.Refer to figure as below.

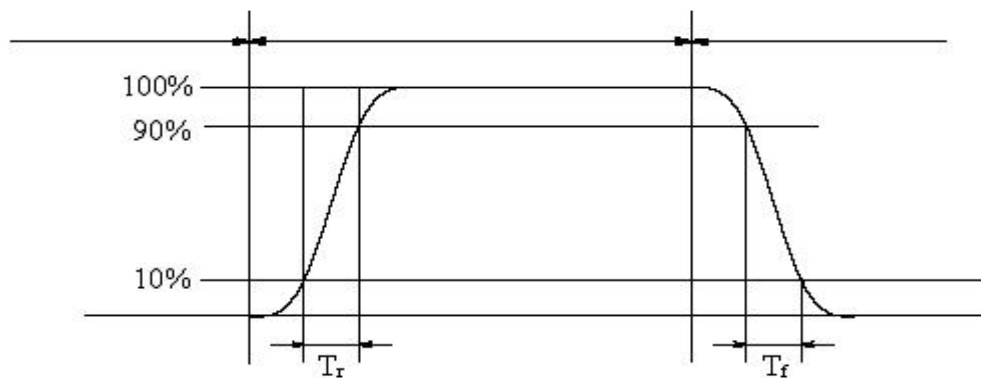

The definition of response time

Note 6: Definition of Color of CIE Coordinate and NTSC Ratio.

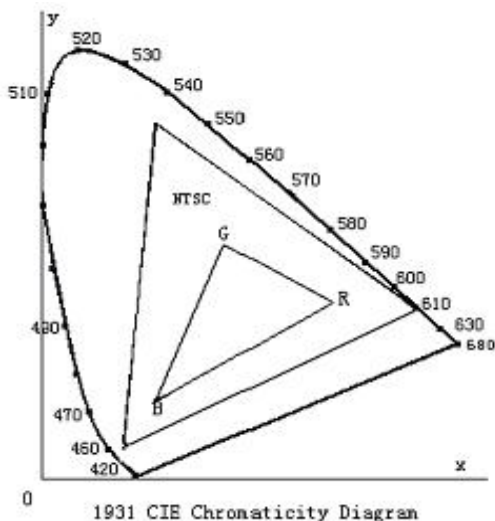

Color gamut:

$$S = \frac{\text{area of RGB triangle}}{\text{area of NTSC triangle}} \times 100\%$$

Note 7: Definition of cross talk.

Cross talk ratio(%)= | pattern A Brightness-pattern B Brightness|/pattern A Brightness\*100

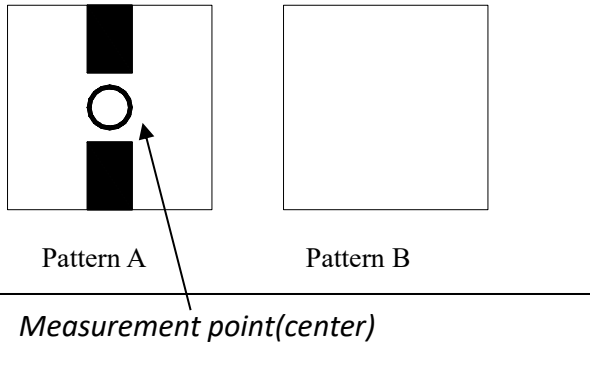

Electric volume value=3F+/-3Hex

## 8. Reliability Test Items and Criteria

No	Test Item	Test condition	Criterion
1	High Temperature Storage	80°C±2°C 96H Restore 2H at 25°C Power off	1. After testing, cosmetic and electrical defects should not happen. 2. Total current consumption should not be more than twice of initial value.
2	Low Temperature Storage	-30°C±2°C 96H Restore 2H at 25°C Power off	
3	High Temperature Operation	70°C±2°C 96H Restore 2H at 25°C Power on	
4	Low Temperature Operation	-20°C±2°C 96H Restore 4H at 25°C Power on	
5	High Temperature/Humidity Operation	50°C±2°C 90%RH 96H Power on	
6	Temperature Cycle	-20°C ← ————— → 60°C  30min 5min 30min  after 5 cycle, Restore 2H at 25°C Power off	

Note:

The inspection terms after reliability test, as below

ITEM	Inspection
Contrast	CR>50%
IDD	IDD<200%
Brightness	Brightness>60%
Color Tone	Color Tone+/-0,05

## 9. Precautions for Use of LCD Modules

### 9.1 Handling Precautions

9.1.1 The display panel is made of glass. Do not subject it to a mechanical shock by dropping it from a high place, etc.

9.1.2 If the display panel is damaged and the liquid crystal substance inside it leaks out, be sure not to get any in your mouth, if the substance comes into contact with your skin or clothes, promptly wash it off using soap and water.

9.1.3 Do not apply excessive force to the display surface or the adjoining areas since this may cause the color tone to vary.

9.1.4 The polarizer covering the display surface of the LCD module is soft and easily scratched. Handle this polarizer carefully.

9.1.5 If the display surface is contaminated, breathe on the surface and gently wipe it with a soft dry cloth. If still not completely clear, moisten cloth with one of the following solvents:

- Isopropyl alcohol
- Ethyl alcohol

Solvents other than those mentioned above may damage the polarizer. Especially, do not use the following:

- Water
- Ketone
- Aromatic solvents

9.1.6 Do not attempt to disassemble the LCD Module.

9.1.7 If the logic circuit power is off, do not apply the input signals.

9.1.8 To prevent destruction of the elements by static electricity, be careful to maintain an optimum work environment.

- a. Be sure to ground the body when handling the LCD Modules.
- b. Tools required for assembly, such as soldering irons, must be properly ground.
- c. To reduce the amount of static electricity generated, do not conduct assembly and other work under dry conditions.
- d. The LCD Module is coated with a film to protect the display surface. Be care when peeling off this protective film since static electricity may be generated.

## 9.2 Storage precautions

9.2.1 When storing the LCD modules, avoid exposure to direct sunlight or to the light of fluorescent lamps.

9.2.2 The LCD modules should be stored under the storage temperature range. If the LCD modules will be stored for a long time, the recommend condition is:

Temperature :         $0^{\circ}\text{C} \sim 40^{\circ}\text{C}$

Relatively humidity:  $\leq 80\%$

9.2.3 The LCD modules should be stored in the room without acid, alkali and harmful gas.

**9.3 The LCD modules should be no falling and violent shocking during transportation, and also should avoid excessive press, water, damp and sunshine.**

**9.4 Quality guarantee for one year from the date of shipment**

**Under the warranty, if the defect is caused by DISEA, DISEA will free repair; if the defect is caused by the customer, DISEA will quote&assist for repair.**

**Outside the warranty, DISEA will quote&assist for repair all defects**

**10. Picture for LCD Module**



Separate packing

Bottom View

No Mounted



Top View



## 11. Package Specifications

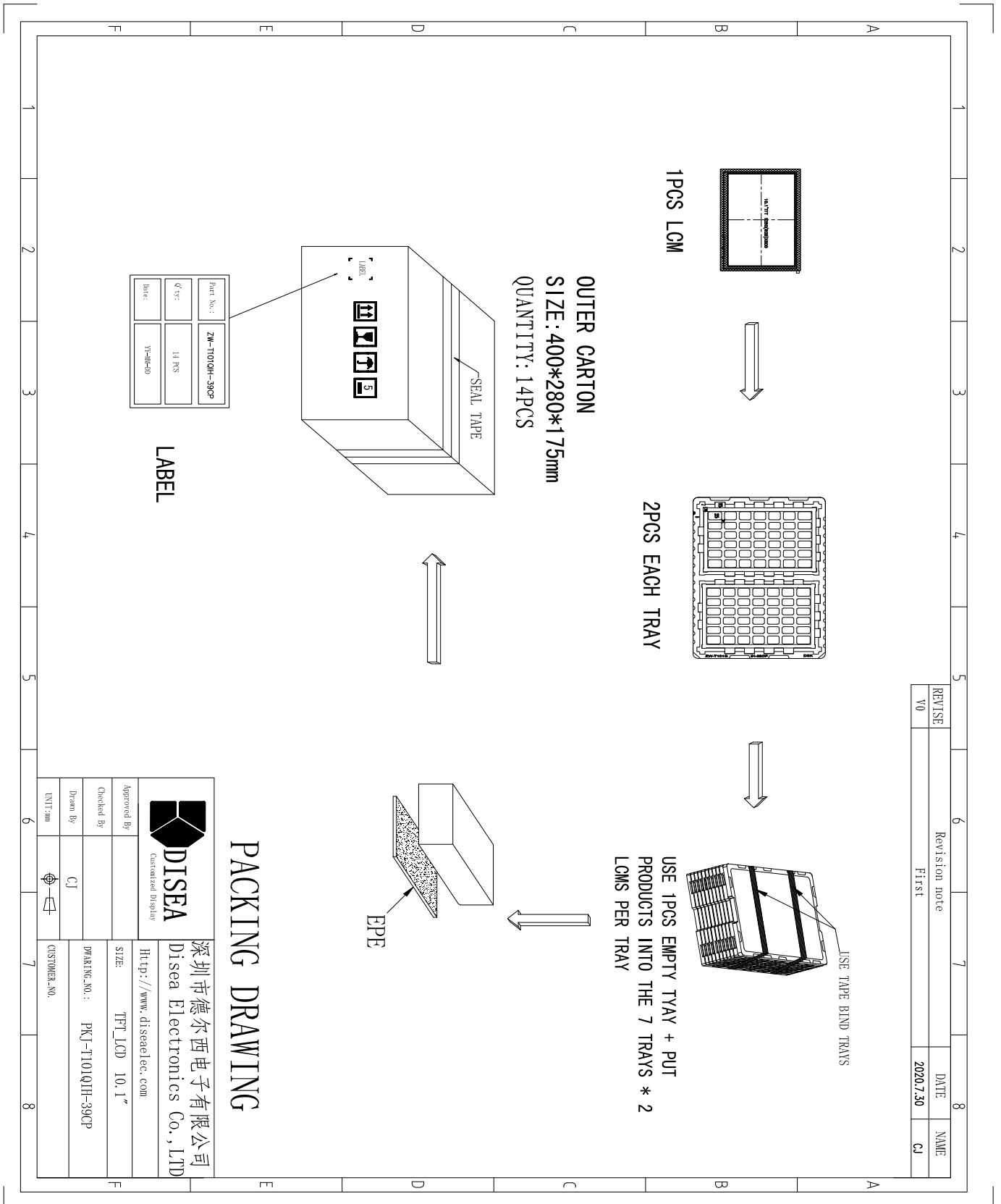

REVISE	Revision note	DATE	NAME
V0	First	2020.7.30	CJ

