

**Features**

- 1.8A, 0.21Ω, 14V Power MOSFET
- Operating input voltage: 2.6V to 12V
- Adjustable Output from VIN to 14V
- 640kHz/1.2MHz pin selectable switching Frequency
- 0.1 μA shutdown Current
- Built-in Soft-Start function
- Small 8-Pin MSOP Package

**Applications**

- LCD Displays
- Digital Cameras
- Portable Applications
- Hand-Held Devices

**General Description**

The AT1780 is a current-mode step-up DC/DC converter with a 1.8A, 0.21Ω power MOSFET. The soft-start function is programmed with an external capacitor, which sets the input current ramp rate. It is ideal for generating bias voltages for LCD panels. Pin selectable frequency 640kHz or 1.2MHz operation results in a low noise output that is easy to filter and faster loop performance. An external compensation pin provides the user flexibility in determining loop dynamics, allowing the use of small, low equivalent series resistance (ESR) ceramic output capacitors.

**Block Diagram**

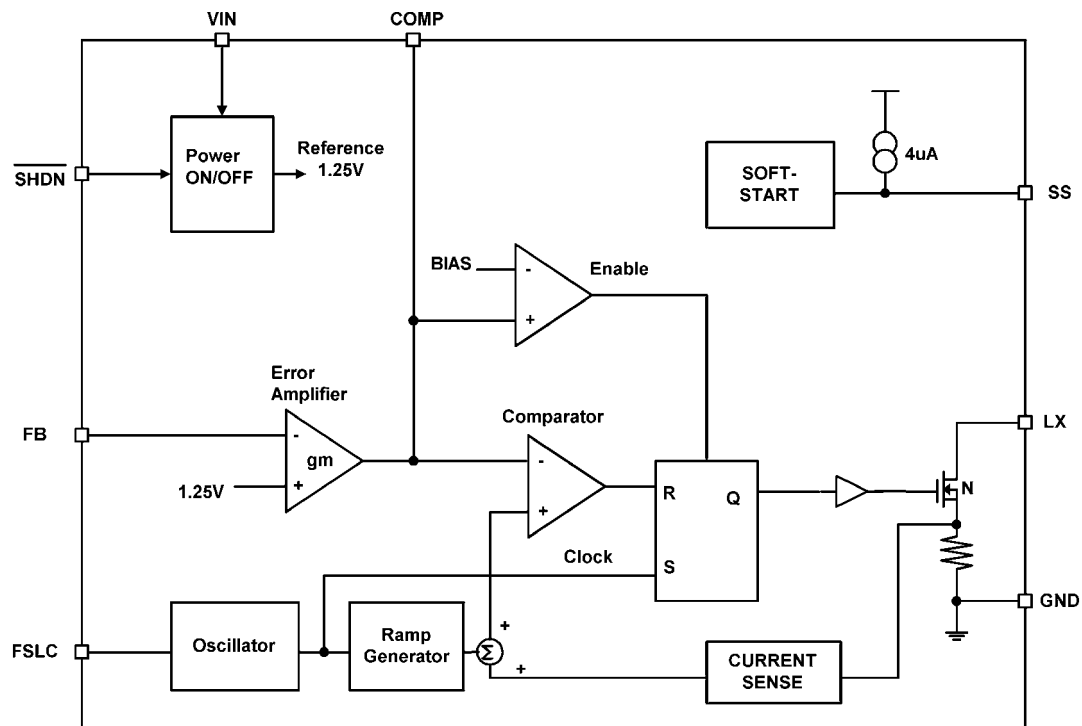

**Aimtron reserves the right without notice to change this circuitry and specifications.**

### Pin Configuration

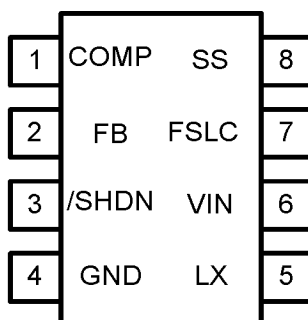

AT1780

### Ordering Information

Part number	Package	Marking
AT1780	MSOP-8	AT1780

### Pin Description

Pin No.	Symbol	I/O	Description
1	COMP	-	Compensation network connection.
2	FB	I	Output voltage feedback input
3	/SHDN	I	Shutdown control input, active low
4	GND	-	Ground
5	LX	O	Switch Pin.
6	VIN	-	Power supply pin.
7	FSLC	I	Frequency select input. Ground=640KHz, VIN=1.2MHz
8	SS	—	Soft-Start control pin.

### Absolute Maximum Ratings

Parameter	Condition	Rated Value		Unit
		Min.	Max.	
LX to GND	—	-0.3	+14	V
IN, /SHDN, FREG, FB to GND	—	-0.3	+6	V
SS, COMP to GND	—	-0.3	V <sub>IN</sub> +0.3	V
RMS LX pin current	—	—	1.2	A
Continuous power dissipation	8pin $\mu$ MAX (TA=+70°C)	—	330	mW
Operating temperature	—	-30	+85	°C
Junction temperature	—	—	+150	°C
Storage temperature	—	-40	+150	°C
Lead temperature	—	—	+300	°C

Stresses beyond those listed under “Absolute Maximum Ratings” may cause permanent damage to the device. These are stress ratings only, and functional operation of the device at these or any other conditions beyond those indicated in the operational sections of the specifications is not implied. Exposure to absolute maximum rating conditions for extended periods may affect device reliability.

### Recommended Operating Conditions

(Ta=+25°C)

Parameter	Symbol	Values			Unit
		Min.	Typ.	Max.	
Power supply voltage	V <sub>IN</sub>	2.5	--	5.5	V
SS pin capacitance	C <sub>PE</sub>	--	0.033	--	$\mu$ F
Phase compensation capacitance	C <sub>COMP1</sub>	--	680	--	p F
Phase compensation capacitance	C <sub>COMP2</sub>	--	20	--	p F
Phase compensation resistance	R <sub>COMP</sub>	--	180	--	K $\Omega$
Oscillation frequency	f <sub>OSC1</sub>	540	708	740	kHz
	f <sub>OSC2</sub>	1000	1220	1500	
Operating temperature	T <sub>OP</sub>	-30	+25	+85	°C

### Electrical Characteristics

(VIN = SHDN = 3V, FREQ = GND, TA = -20°C to +85°C, unless otherwise noted. Typical values are at TA = +25°C.)

Parameter	Symbol	Condition	Values			Unit	
			Min.	Typ.	Max.		
Entire device	Input Supply Range	V <sub>IN</sub>		2.5	--	5.5	V
	V <sub>IN</sub> Undervoltage Lockout	UVLO	V <sub>IN</sub> rising, typical hysteresis is 40mV, LX remains off below this level	2.25	2.46	2.52	V
	Quiescent Current	I <sub>IN</sub>	V <sub>FB</sub> = 1.3V, not switching		0.218	0.35	mA
			V <sub>FB</sub> = 1.0V, switching		2.045	5	
Shutdown Supply Current	I <sub>IN</sub>	/SHDN = GND		16		μA	
Error amplifier	Feedback Voltage	V <sub>FB</sub>	Level to produce V <sub>COMP</sub> = 1.24V	1.245	1.25	1.255	V
	FB Input Bias Current	I <sub>FB</sub>	V <sub>FB</sub> = 1.25V		0	40	nA
	Feedback-Voltage Line Regulation		Level to produce V <sub>COMP</sub> = 1.24V, 2.6V < V <sub>IN</sub> < 5.5V		0.05	0.15	%/V
	Transconductance	gm	ΔI = 5μA	-	280	-	μmhos
	Voltage Gain	A <sub>v</sub>	--		500		V/V
Sawtooth wave oscillator (OSC)	Frequency	fosc	FSLC = GND	540	640	740	kHz
			FSLC = IN	1050	1200	1350	
	Maximum Duty Cycle	DC	FSLC = GND	79	91.3	92	%
			FSLC = IN		82.1		
N-CHANNEL SWITCH	Current Limit	I <sub>LIM</sub>	V <sub>FB</sub> = 1V, duty cycle = 65%	1.7	-	2.3	A
	On-Resistance	R <sub>ON</sub>	I <sub>LX</sub> = 1.2A		0.21	0.3	Ω
	Leakage Current	I <sub>LXOFF</sub>	V <sub>LX</sub> = 12V		0.01	20	μA
	Current-Sense Transresistance	R <sub>CS</sub>		0.3	0.45	0.65	V/A
SOFT-START	Reset Switch Resistance					100	Ω
	Charge Current		V <sub>SS</sub> = 1.2V	1.5	2.55	7	μA
CONTROL INPUTS	Input Low Voltage	V <sub>IL</sub>	/SHDN, FREQ; V <sub>IN</sub> = 2.6V to 5.5V		0.51 × V <sub>IN</sub>		V
	Input High Voltage	V <sub>IH</sub>	/SHDN, FREQ; V <sub>IN</sub> = 2.6V to 5.5V		0.57 × V <sub>IN</sub>		V
	Hysteresis		SHDN, FREQ		0.07 × V <sub>IN</sub>		V
	FSLC Pull-Down Current	I <sub>FSLC</sub>		1.5	5	9	μA
	/SHDN Input Current	I <sub>SHDN</sub>			0.001	1	μA

Typical Curve (see Application circuit)

CH1:LX CH2:Vout CH4:Inductor Current

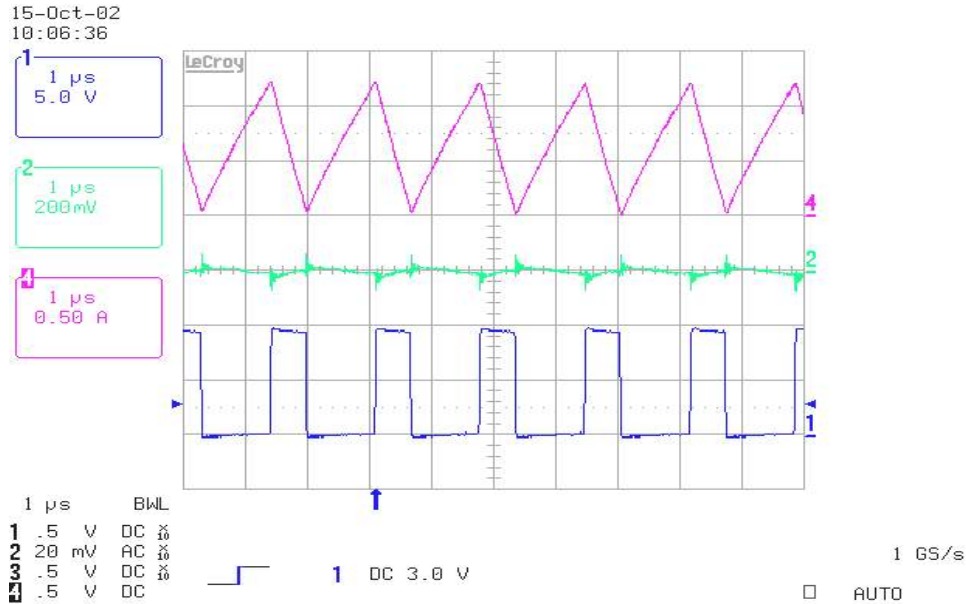

Fig 1. Switching Waveform

CH1:/SHDN CH2:Vout CH3:SS CH4:Inductor Current

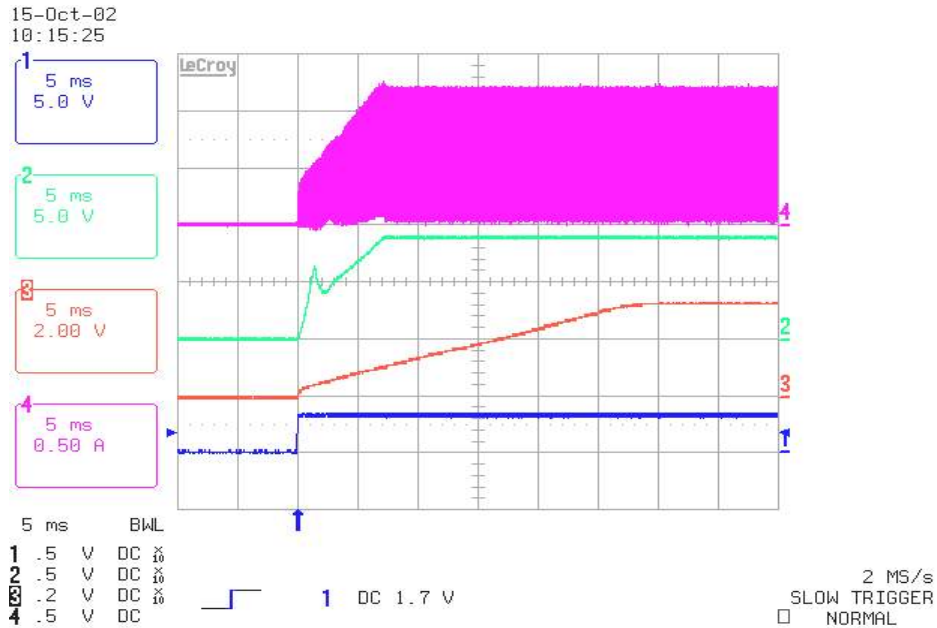
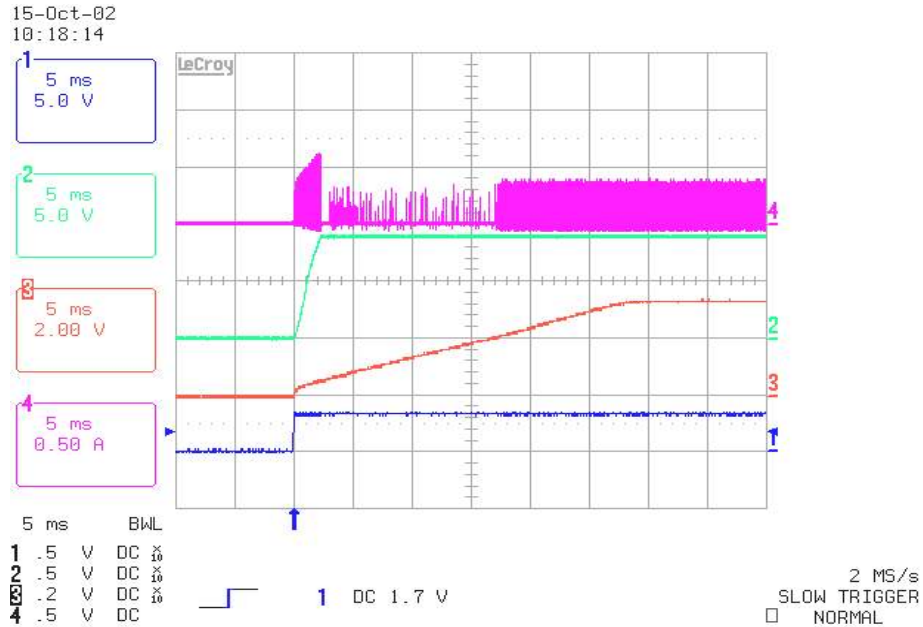

Fig 2. Start-up Waveform with Soft-Start (Iout=200mA)

CH1:/SHDN CH2:Vout CH3:SS CH4:Inductor Current



**Fig 3. Start-up Waveform with Soft-Start ( $I_{out}=10mA$ )**

CH1:/SHDN CH2:Vout CH3:SS CH4:Inductor Current

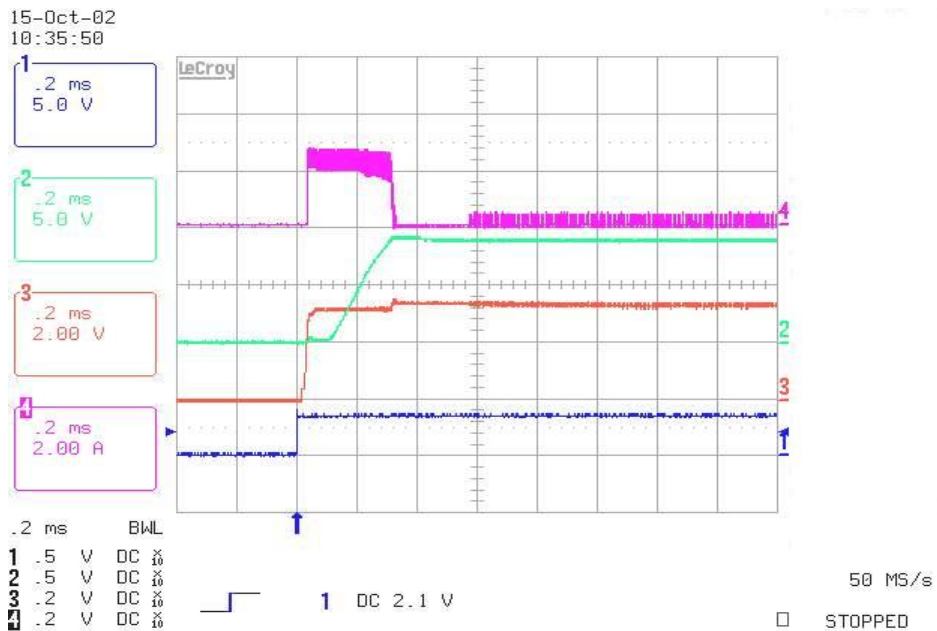

**Fig 4. Start-up Waveform without Soft-Start ( $I_{out}=10mA$ )**

Typical Application Circuit

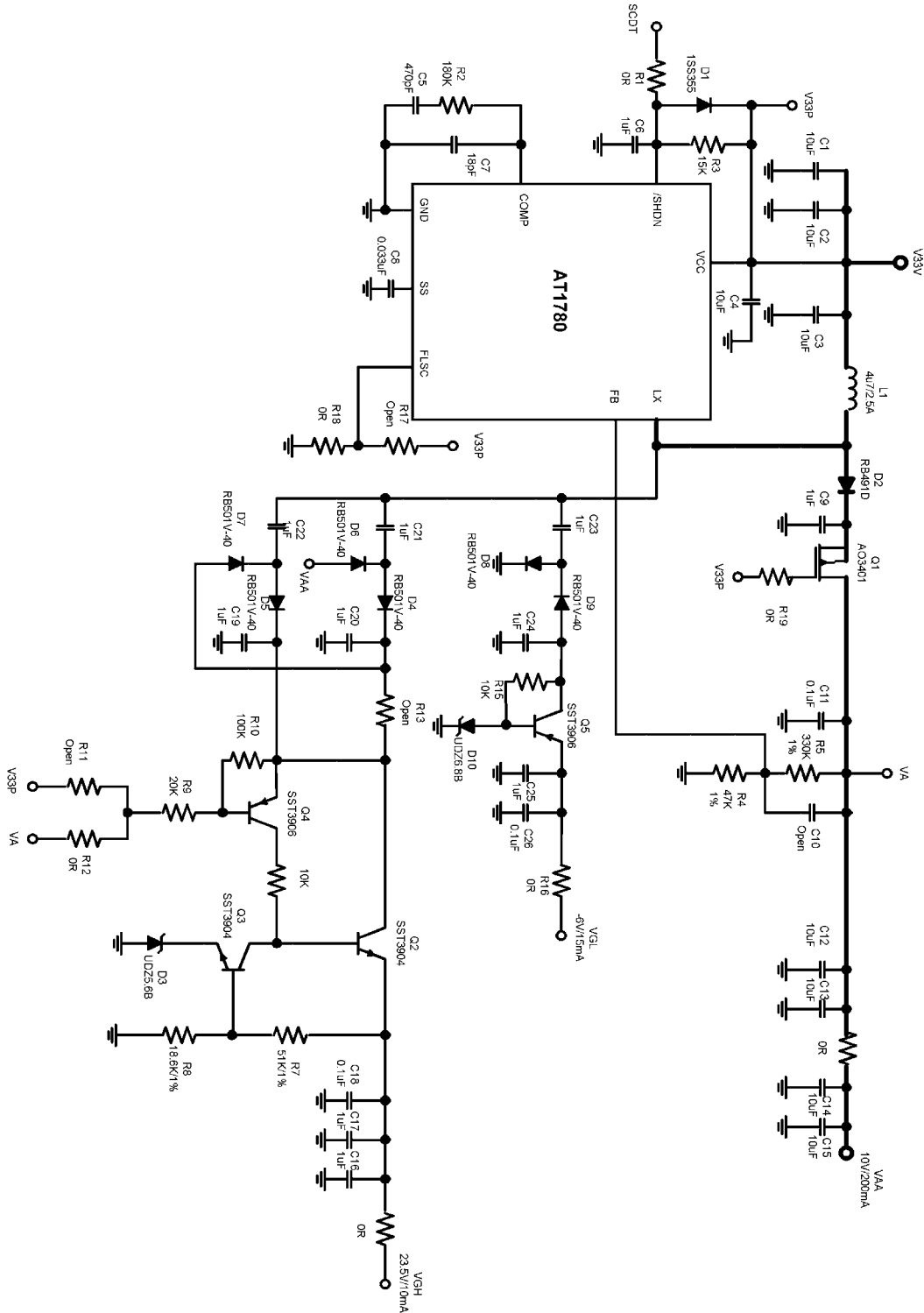

2F, No.10, Prosperity RD. II, Science-Based Industrial Park, Hsinchu 300, Taiwan, R.O.C.

Tel: 886-3-563-0878

Fax: 886-3-563-0879

WWW: <http://www.aimtron.com.tw>

Email: [service@aimtron.com.tw](mailto:service@aimtron.com.tw)

**Small Outline 8-pin Plastic MSOP**

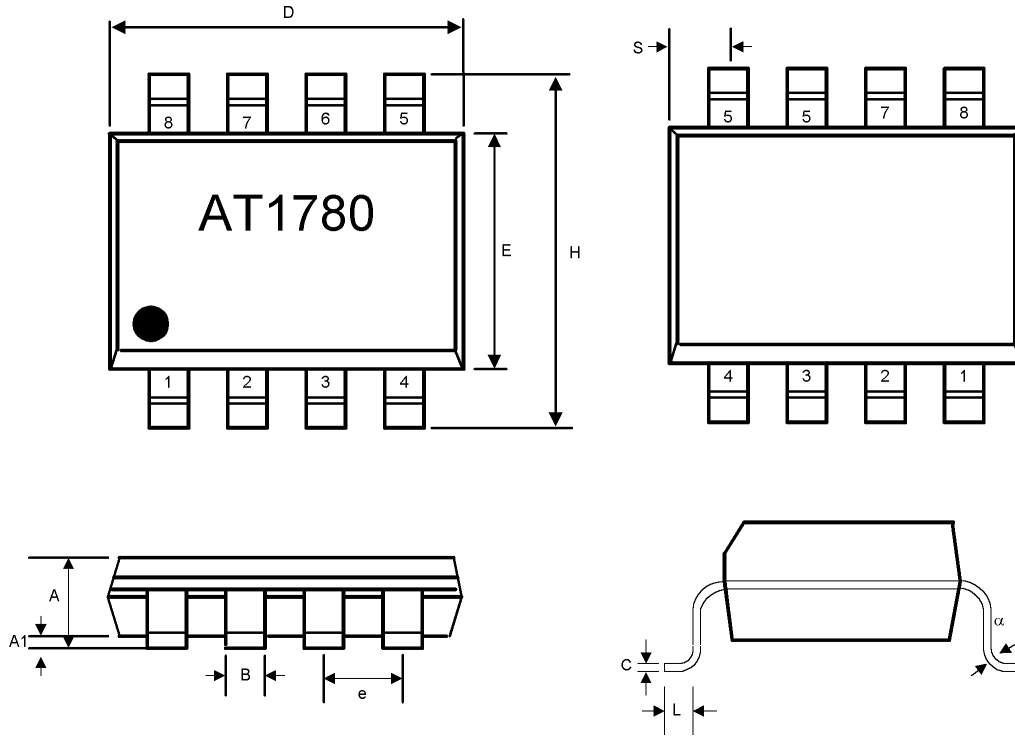

SYMBOL	INCHES		MILLIMETERS		NOTES
	MIN	MAX	MIN	MAX	
A	0.037	0.043	0.94	1.10	-
A1	0.002	0.006	0.05	0.15	-
B	0.010	0.014	0.25	0.36	-
C	0.005	0.007	0.13	0.18	-
D	0.116	0.120	2.95	3.05	-
e	0.0256 BSC		0.65 BSC		-
E	0.116	0.120	2.95	3.05	-
H	0.188	0.198	4.78	5.03	-
L	0.016	0.026	0.41	0.66	-
$\alpha$	0°	6°	0°	6°	-
S	0.207 BSC		0.525 BSC		-



**Reflow Condition (IR/Convection or VPR Reflow)**

Reference JEDEC Standard J-STD-020A

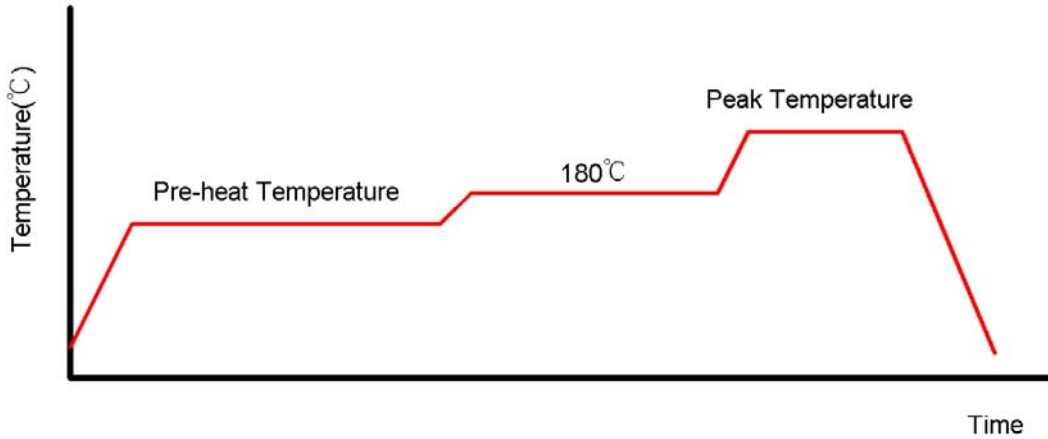

**Classification Reflow Profiles**

	Convection or IR/Convection	VPR
Average Heating Rate(180°C to peak)	5°C/second max.	10°C/second max.
Preheat Temperature(125±20°C)	120 seconds max.	
Temperature maintained above 180°C	10~150 seconds	
Time within 5°C of actual Peak Temperature	10~20 seconds	60 seconds
Peak Temperature Range(Note 1)	219~225°C or 235~240°C	219~225°C or 235~240°C
Cooling Rate	6°C /second max.	10°C/second max.
Time 25°C to Peak Temperature	6 minutes max.	

\*1 The maximum peak temperatures for IR and VP reflow are depending on package dimensions.

**Package Reflow Conditions**

Pkg. Thickness ≥2.5mm and all bags	Pkg. Thickness <2.5mm and Pkg. Volume ≥350 mm <sup>3</sup>	Pkg. Thickness <2.5mm and Pkg. Volume <350 mm <sup>3</sup>
Convection 219~225°C		Convection 235~240°C
VPR 219~225°C		VPR 235~240°C
IR/Convection 219~225°C		IR/Convection 235~240°C