



HONGLI ZHIHUI
鸿利智汇

BYTECH

Technical Data Sheet

Specification

CMH268A1V113Z6-S2P2



BYTECH

Bytech Electronics CO., Ltd is the first company in China to launch the real inorganic package UV LED devices and core components for application based on CMH technology.

CMH technology platform is a kind of package technology which adopts ceramic, metal, hard glass as package materials. CMH technology platform originates independent intellectual property owned by Bytech Electronics CO., LTD, which is suitable for vacuum encapsulation, especially suitable for ensuring reliability of deep UV products.

DESIGN	CHECKED	APPROVED
2017.06.22	2017.06.22	2017.06.22
CHEN	研发专用章	TANG

By technology, for people.



Under Development	
Mass Production	●



ATTENTION
OBSERVE PRECAUTIONS
FOR HANDLING
ELECTROSTATIC
DISCHARGE
SENSITIVE
DEVICES

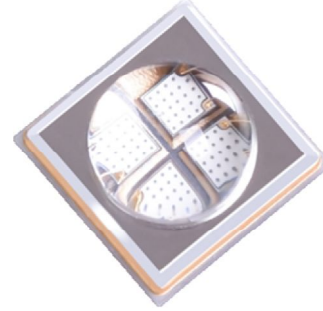

Features

- CMH real inorganic package
- Hermetic package
- Dimension 7.0mm×7.0mm×3.7mm
- Long operating life
- High reliability
- Superior ESD protection
- RoHS compliant

Applications

- Fluorescent spectroscopy
- Sensors and monitors
- Bio-analysis/detection
- Phototherapy
- UV curing

Package Dimensions (Unit: mm)

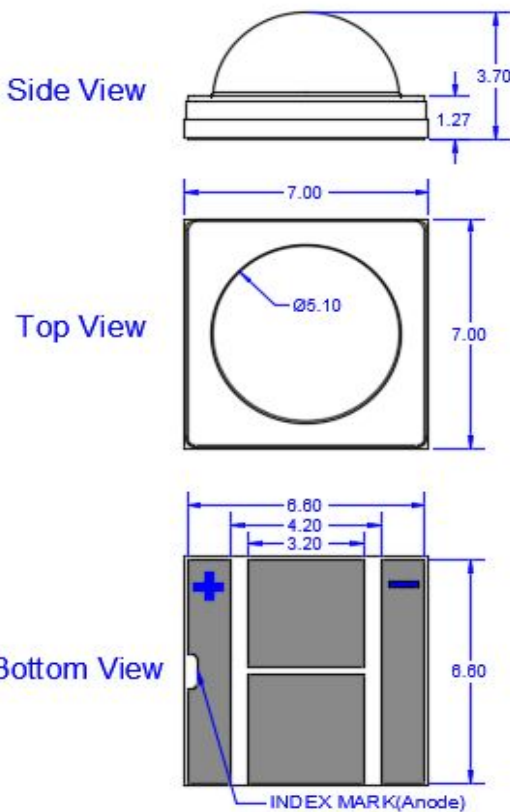

Product ID:

395nm: CMH268A1V113Z6-S2P2

Circuit:

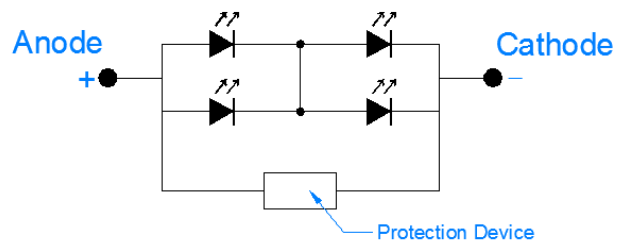

Tolerance : ± 0.20 mm



Characteristics of UV LED

1. Electrical / Optical Characteristics (Ta=25°C,RH=40%)

Parameter	Symbol	Units	CMH268A1V113Z6-S2P2 (IF=2000mA)
Peak Wavelength [1]	λ_p	nm	390-400
Radiant Flux [2]	Φ_e [3]	mW	7000-8000
Forward Voltage [4]	VF	V	7.0-8.6
Thermal Resistance [5]	R _{th}	°C/W	1-2
Spectrum Half Width	$\Delta\lambda$	nm	15
View Angle	2 $\theta_{1/2}$	deg	60

Notes:

[1].Peak wavelength measurement tolerance:±3nm

[2].Radiant flux measurement tolerance:±10%

[3]. Φ_e is the total radiant Flux as measured with an integrated sphere

[4].Forward voltage measurement tolerance:±3%

[5].R_{th} is the thermal resistance between chip junction to PCB board bottom

2. Absolute Maximum Ratings (Ta=25°C,RH=40%)

Parameter	Symbol	Units	CMH268A1V113Z6-S2P2
Maximum Rating Forward Current	I _{Fmax}	mA	3000
Maximum Rating Junction Temperature	T _{jmax}	°C	125
Operating Temperature Range	T _{opr}	°C	-40 ~ +85
Storage Temperature Range	T _{stg}	°C	-40 ~ +100

Notes:

Operating the LED beyond the listed maximum ratings may affect device reliability and cause permanent damage.

These or any other conditions beyond those indicated under recommended operating conditions are not implied.

The exposure to the absolute maximum rated conditions may affect device reliability.



3.Ranks (IF=2000mA, Ta=25°C, RH=40%)

波长 (nm)	电压 (V)	光功率 (mw)					
		5000-6000	6000-7000	7000-8000	8000-9000	9000-10000	10000-11000
390-395	7.0-7.2	A1101	A1102	A1103	A1104	A1105	A1106
	7.2-7.4	A1107	A1108	A1109	A1110	A1111	A1112
	7.4-7.6	A1113	A1114	A1115	A1116	A1117	A1118
	7.6-7.8	A1119	A1120	A1121	A1122	A1123	A1124
	7.8-8.0	A1125	A1126	A1127	A1128	A1129	A1130
	8.0-8.2	A1131	A1132	A1133	A1134	A1135	A1136
	8.2-8.4	A1137	A1138	A1139	A1140	A1141	A1142
	8.4-8.6	A1143	A1144	A1145	A1146	A1147	A1148
	8.6-8.8	A1149	A1150	A1151	A1152	A1153	A1154
	8.8-9.0	A1155	A1156	A1157	A1158	A1159	A1160
395-400	7.0-7.2	A1299	A1300	A1301	A1302	A1303	A1304
	7.2-7.4	A1305	A1306	A1307	A1308	A1309	A1310
	7.4-7.6	A1311	A1312	A1313	A1314	A1315	A1316
	7.6-7.8	A1317	A1318	A1319	A1320	A1321	A1322
	7.8-8.0	A1323	A1324	A1325	A1326	A1327	A1328
	8.0-8.2	A1329	A1330	A1331	A1332	A1333	A1334
	8.2-8.4	A1335	A1336	A1337	A1338	A1339	A1340
	8.4-8.6	A1341	A1342	A1343	A1344	A1345	A1346
	8.6-8.8	A1347	A1348	A1349	A1350	A1351	A1352
	8.8-9.0	A1353	A1354	A1355	A1356	A1357	A1358

Notes:

- *Forward voltage measurement tolerance:±3%
- *Radiant flux measurement tolerance:±10%
- *Φ_e is the total radiant Flux as measured with an integrated sphere
- *LEDs from the above ranks will be shipped.
- *The rank combination ratio per shipment will be decided by Bytech.
- *Peak wavelength measurement tolerance:±3nm



Under Development	
Mass Production	●

Characteristics Diagrams

1. Relative Spectrum Power Distribution

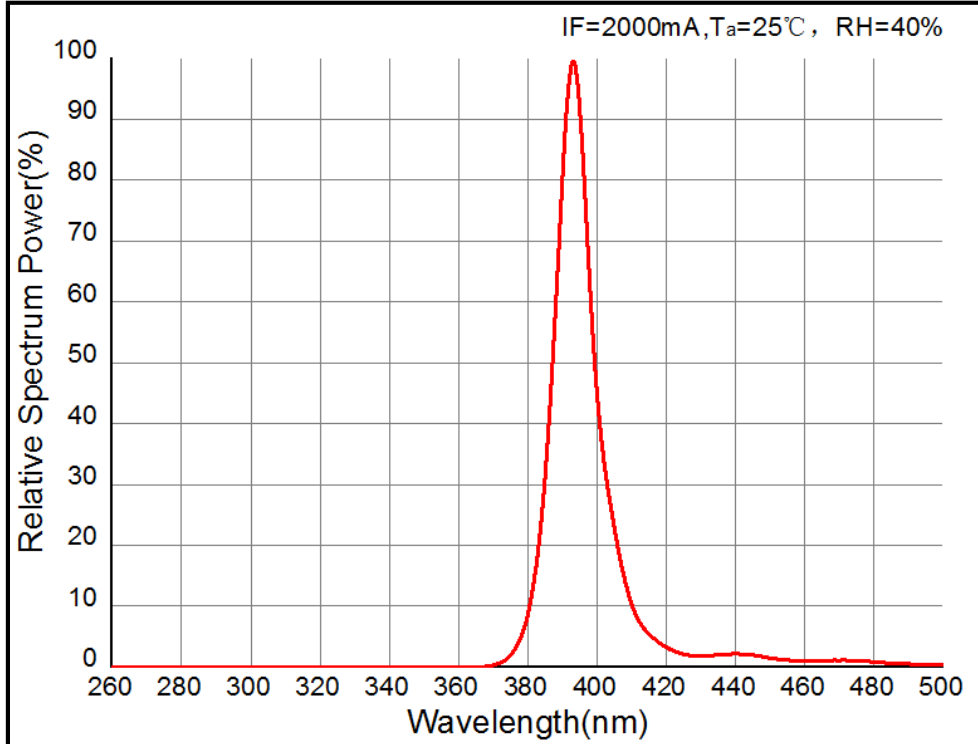

2. Forward Voltage vs Forward Current

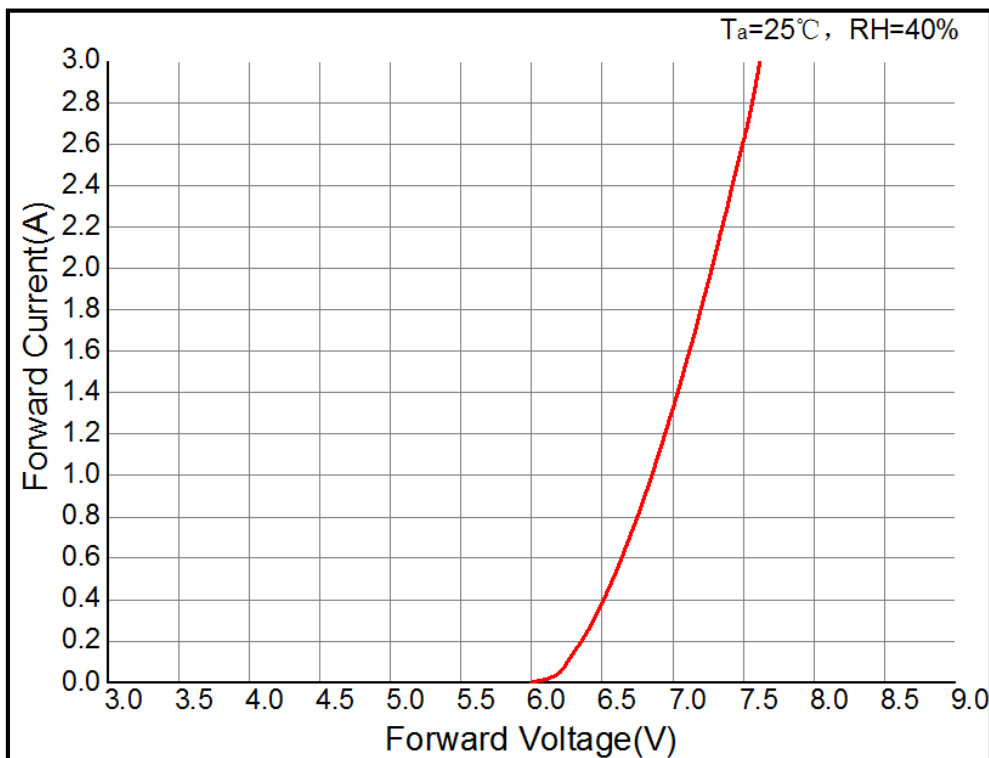



Under Development	
Mass Production	●

3. Relative Radiation Flux vs Forward Current

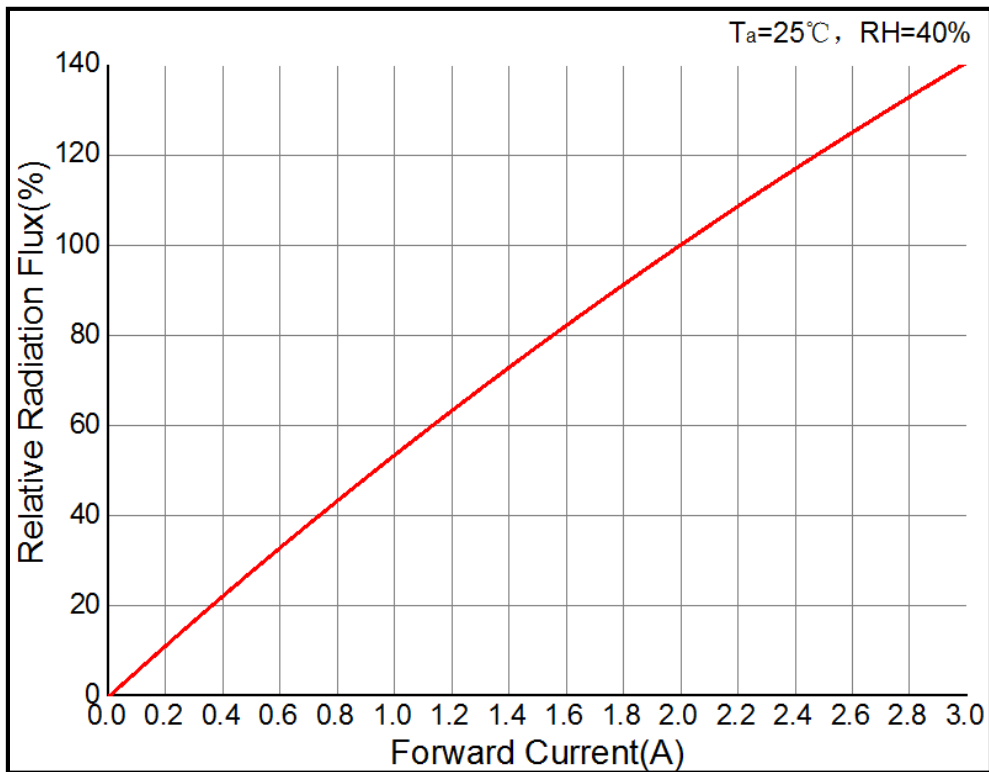

4. Peak Wavelength vs Forward Current

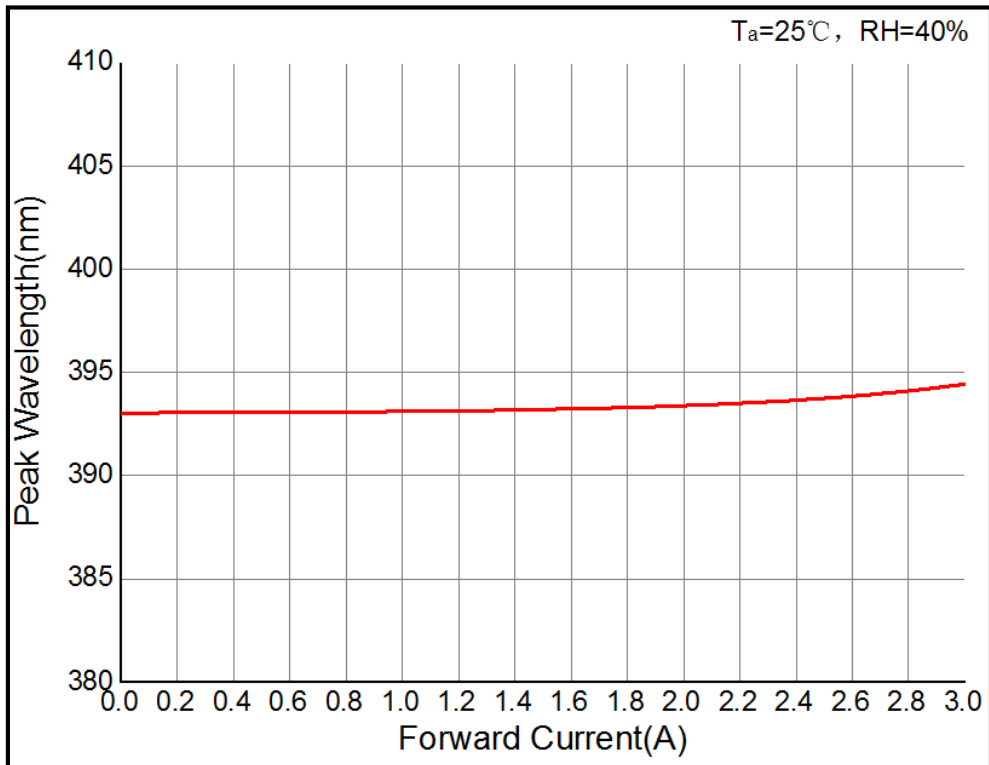



Under Development	
Mass Production	●

5. Spectrum Half-Wave Width vs Forward Current

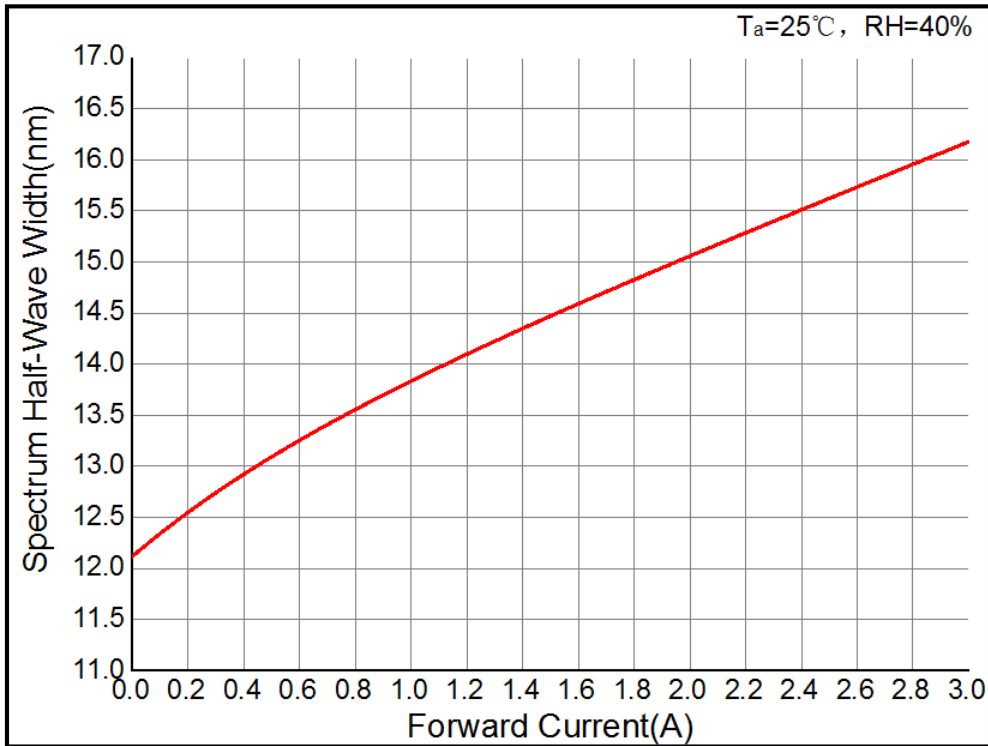

6. Spatial Distribution Graph

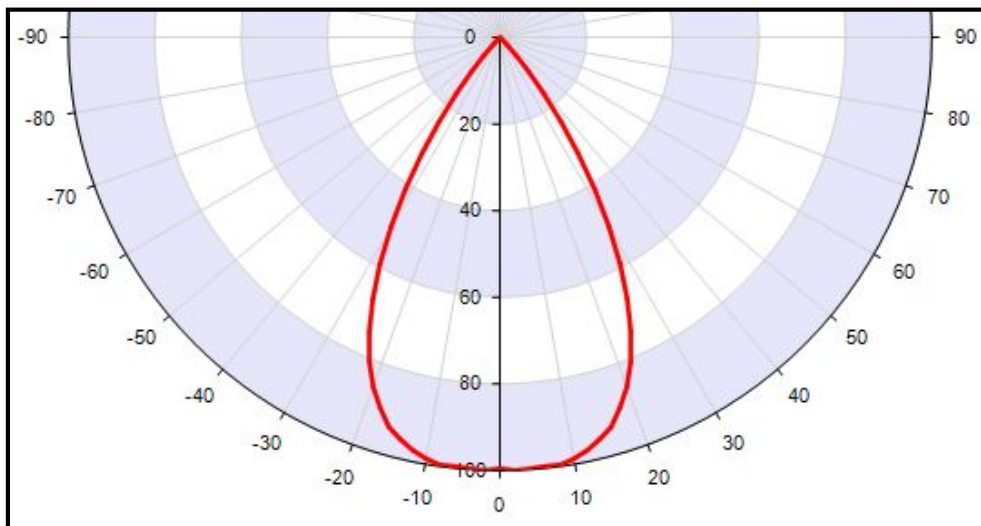



Under Development	
Mass Production	●

Product Application Information

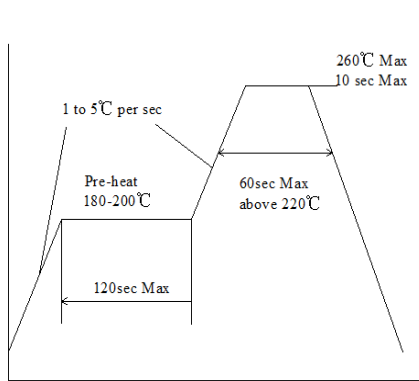

Recommended Reflow Soldering Condition
(Lead-free solder)

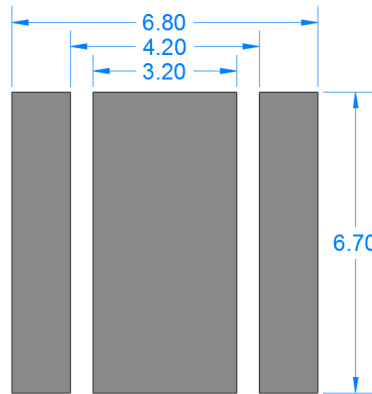

Recommended Soldering pad Layout
(Unit: mm)

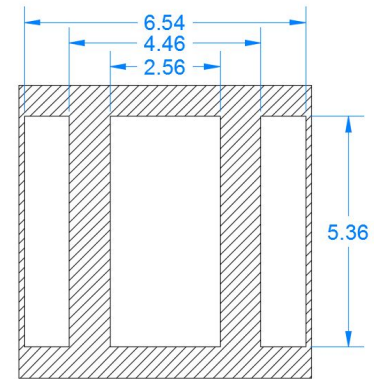

Recommended Soldering Mask Layout
(Unit: mm)

Notes:

- *This LED is designed to be reflow soldered on to a PCB. If dip soldered or hand soldered, Bytech cannot guarantee its reliability.
- *Reflow soldering must not be performed more than twice.
- *Avoid rapid cooling. Ramp down the temperature gradually from the peak temperature.
- *Nitrogen reflow soldering is recommended. Air flow soldering conditions can cause optical degradation, caused by heat and/or atmosphere.
- *Repairing should not be done after the LEDs have been soldered.
It should be confirmed beforehand whether the characteristics of the LEDs will or will not be damaged by repairing.
- *The Die Heat Sink should be soldered to customer PCB.
If it is difficult or impossible, use high heat-dissipating adhesive.
- *When soldering, do not apply stress to the LED while the LED is hot.
- *When using a pick and place machine, choose an appropriate nozzle for this product.
- *The recommended soldering pad pattern is designed for attachment of the LED without problems.
When precise mounting accuracy is required, such as high-density mounting, ensure that the size and shape of the pad are suitable for the circuit design.
- *When flux is used, it should be a halogen free flux. Ensure that the manufacturing process is not designed in a manner where the flux will come in contact with the LEDs.
- *Make sure that there are no issues with the type and amount of solder that is being used.



Under Development	
Mass Production	●

Packing Information

Unit : mm

1. Tape

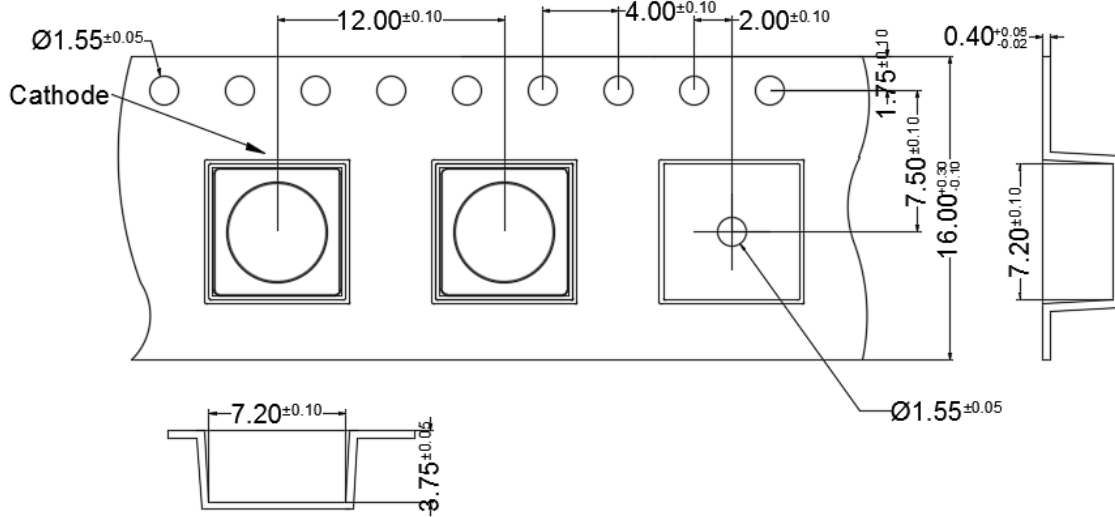

2. Trailer and Leader

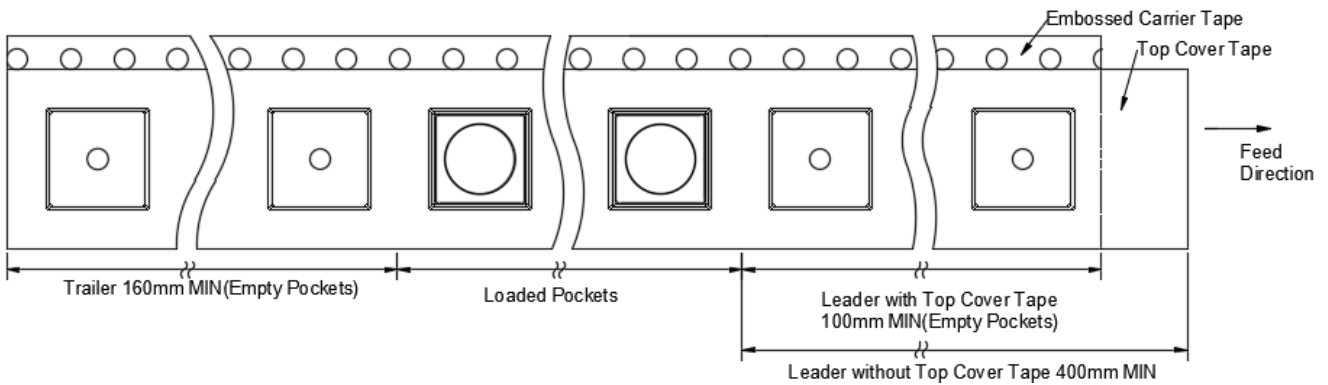

3. Reel

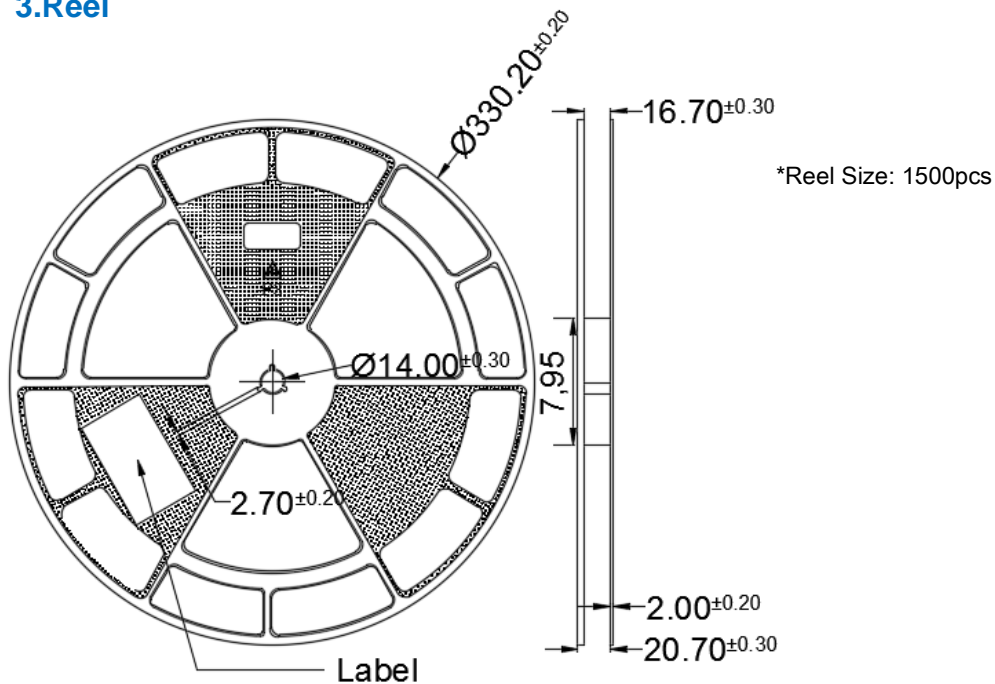



Under Development	
Mass Production	●

Packing Information

4. Reels are shipped with desiccants in heat-sealed moisture-proof bags.

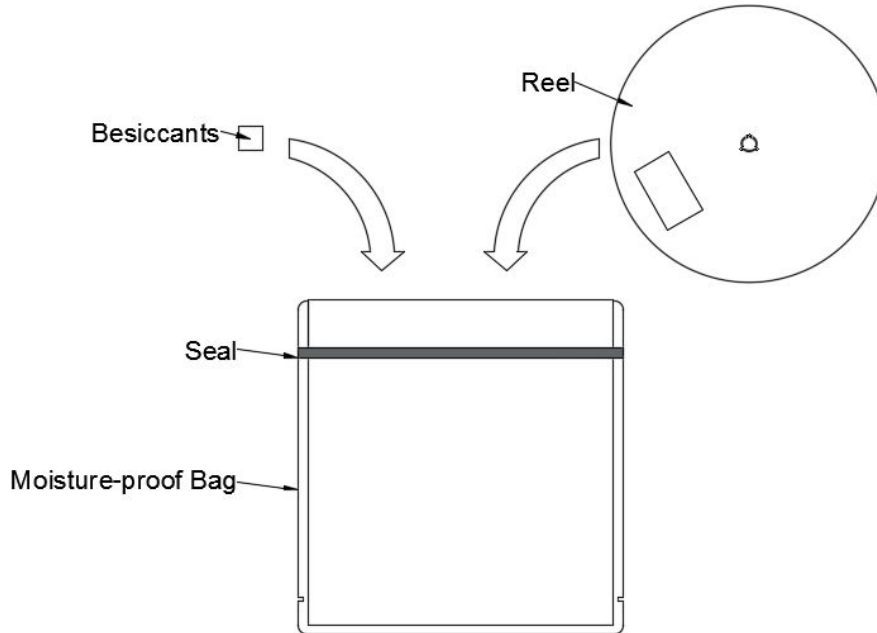

5. Moisture-proof bags are packed in cardboard boxes.

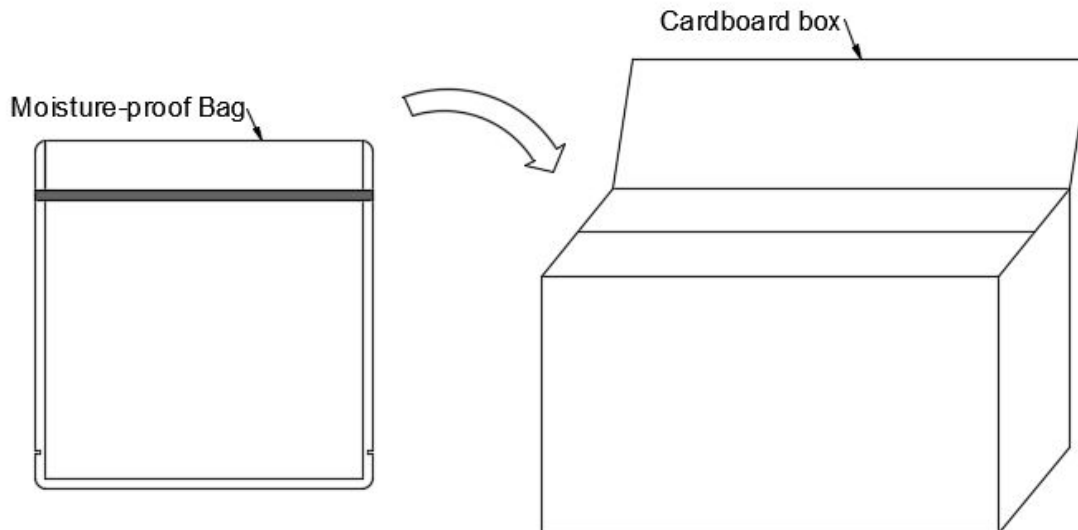



Under Development	
Mass Production	●

CAUTIONS

1. Handling Precautions

- Do not handle the LEDs with bare hands as it will contaminate the LENS surface and may affect the optical characteristics.
- When handling the product with tweezers, be careful not to apply excessive force to glass LENS as it may cause the surface scratch.
- Dropping the product may cause damage.

2. Electrostatic Discharge (ESD)

- The product are sensitive to static electricity or surge voltage. ESD can damage a die and its reliability. When handling the products, the following measure against electrostatic discharge are strongly recommended:

Eliminating wrist strap, ESD footwear, clothes, and floors

Grounded workstation equipment and tools

ESD table/shelf mat made of conductive materials

- Ensure that tools, jigs and machines that are being used are properly grounded and that proper grounding techniques are used in work areas. For devices/equipment that mount the LEDs, protection against surge voltages should also be used.

- The customer is advised to check if the LEDs are damage by ESD

When performing the characteristics inspection of the LEDs in the application.

Damage can be detected with a forward voltage measurement at low current($\leq 1\text{mA}$).

3. Eye Safety

- Please proceed with caution when handling any UVLEDs driven at low or high current.

Since UV light can be harmful to eyes, do Not look directly into the UV light, even through an optical instrument.

- UV protective glasses are required to use in order to avoid damage by UV light in case of viewing UV light directly.

