



JL World Corporation Limited
 1907 Westands Centre, 20 Westands Road, Quarry Bay, Hong Kong
 Tel : 25650319 Fax : 25656979 Web : www.jlworld.com

Document Number : 0210-68
 Revision : A4
 Total Pages : 5
 Prepare by : Leo Sin
 Date : 3 April, 2006

SoniCrest Acoustic Components

Document Type : Specification
 Product Type : Electro-Magnetic Sound Generator Component
 Part Number : HCM0903AX

A2 - update format & layout by Leo Sin on 24 Oct., 2005		
A3 - update mechanical layout by Leo Sin on 10 Feb., 2006		
A4 - update marking layout by Leo Sin on 3 Apr., 2006		

This material is the property of JL World Corporation Limited.
 Unauthorized copying or use of this material is prohibited.

1. Purpose and Scope

This document contains both general requirements, qualification requirements, and those specific electrical, mechanical requirements for this part.

2. Description

ø9mm electro-magnetic sound generator with built-in oscillation circuit.

3. Application

Computers and Peripherals, Portable Equipment, Automobile Electronics, POS System, Household Appliances, etc.

4. Component Requirement

4.1. General Requirement

4.1.1.	Operating Temperature Range	: -40°C to +85°C
4.1.2.	Storage Temperature Range	: -40°C to +85°C
4.1.3.	Weight	: 0.8g
4.1.4.	Masking Label	: Yes

4.2. Electrical Requirement

4.2.1.	Rated Voltage	: 3V
4.2.2.	Operating Voltage	: 2V to 5V
4.2.3.	Rated Current (applying Rated Voltage)	: ≤ 30mA
4.2.4.	Sound Pressure Level at 10cm (applying Rated Voltage)	: ≥ 82dBA
4.2.5.	Generated Frequency (applying Rated Voltage)	: 3200Hz ± 300Hz

4.3. Mechanical Requirement

4.3.1.	Layout and Dimension	: See Section 6, Figure 3
--------	----------------------	---------------------------

4.4. Test Setup of SPL and Frequency

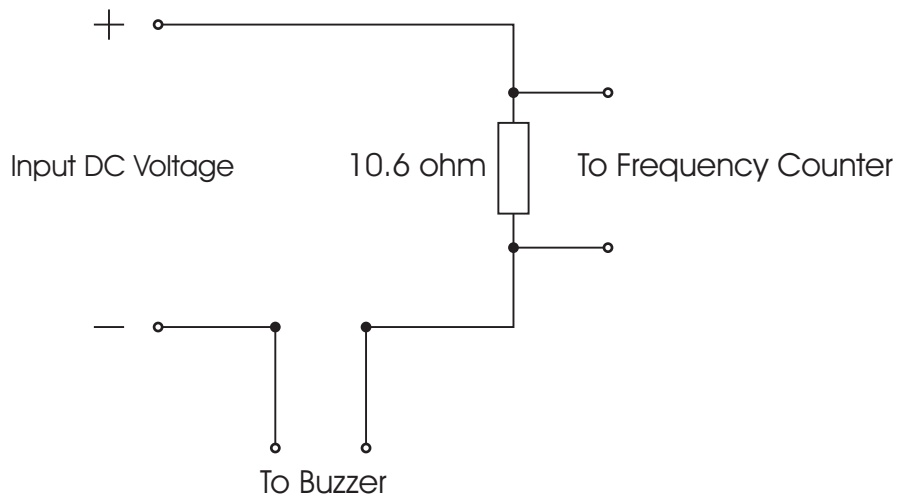

Figure 1. Frequency Testing Circuit

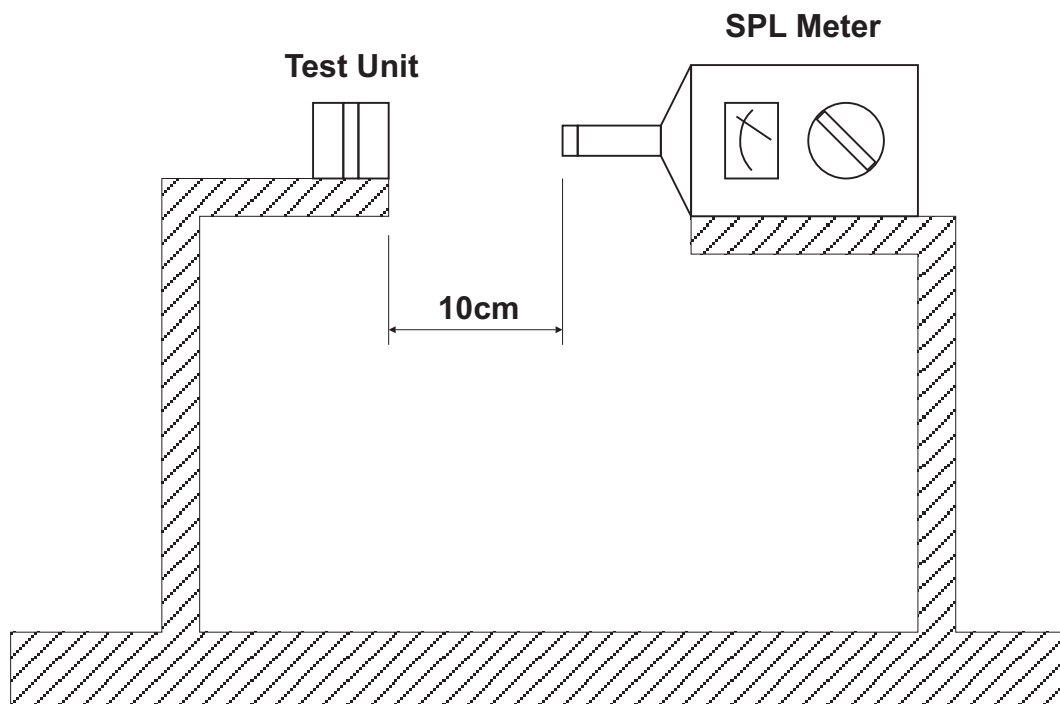

Figure 2. SPL Inspection Test Fixture

Notes : Input 3V DC into samples. Measure SPL using a calibrated SPL meter 10cm from the alert port. Sound level meter to be in accordance with IEC651 (1979) Type 1 and/or ANSI S1.4-1983. The meter must be checked on a daily basis using a calibrated acoustic calibrator recommended by the manufacturer. Measurement should be carried out in a free field environment or at least 40cm from any surface.

5. Reliability Test

- 5.1. Operating Life** : Subject samples to room condition for 1000 hours with rated voltage. Components must be fully stabilized before data is taken, which may require up to a 2 hours soak.
- 5.2. High Temperature** : Subject samples to +85°C and operate for 96 hours with rated voltage. Components must be fully stabilized at temperature extremes before data is taken, which may require up to a 2 hours soak.
- 5.3. Low Temperature** : Subject samples to -40°C and operate for 96 hours with rated voltage. Components must be fully stabilized at temperature extremes before data is taken, which may require up to a 2 hours soak.
- 5.4. Temperature Cycle** : Each temperature cycle shall consist of 30 minutes at -20°C, 15 minutes at +20°C, 30 minutes at +60°C and 15 minutes at +20°C. Test duration is for 5 cycles. Components must be fully stabilized at temperature extremes before data is taken, which may require up to a 2 hours soak.
- 5.5. Static Humidity** : Precondition at room temperature for 1 hour. Then expose to +65°C with 90 to 95% relative humidity for 12 hours. Finally dry at room ambient for 2 hours before taking final measurement.
- 5.6. Drop Test** : Drop samples naturally from the height of 0.7m onto a wooden board six times (three direction).

6. Mechanical Layout

Unit : mm

Tolerance : Linear XX.X = ±0.3
 XX.XX = ±0.05
 Angular = ±0.25°
 (unless otherwise specified)

Top View

Side View

Bottom View

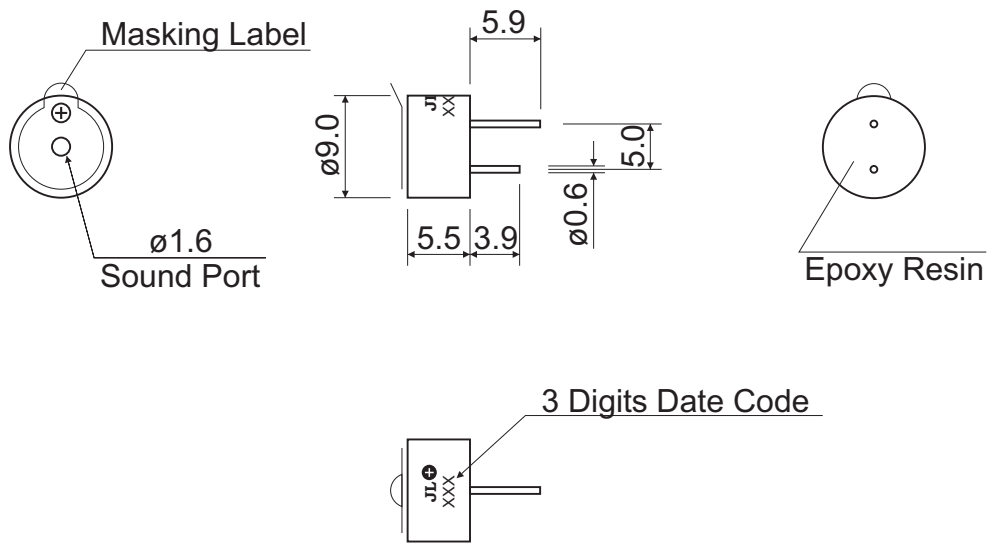

Figure 3. HCM0903AX Mechanical Layout