

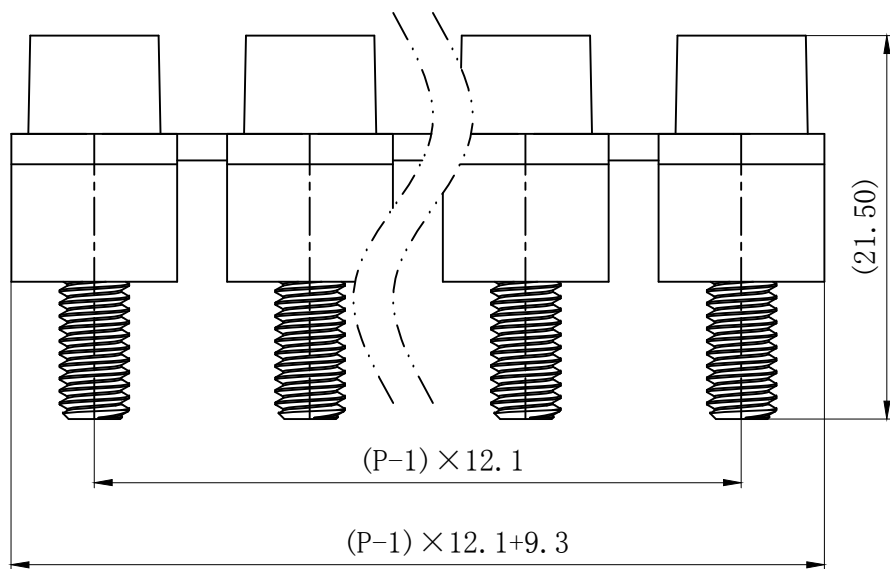

宁波速普电子有限公司

NINGBO SUPU ELECTRONICS.CO.,LTD

产品规格书
Product Specification

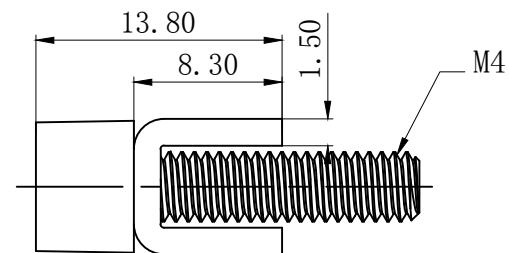
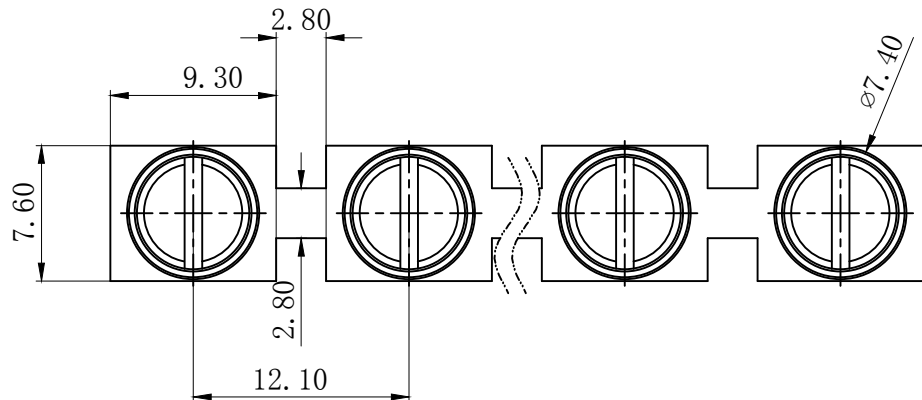

订货信息
Order Info

订货号 PART NUMBER	位数 POIes
316302	2
316303	3
...	...
316309	9
316310	10

其他信息/Other information

塑件/Housing	PA66
触点材料/Contact	铜合金/Copper alloy
镀层/Coating	镍/Nickel
阻燃等级/Flame retardant rating	V2
储存及运输环境温度/ Strrage ambient temperature	-40°C - +85°C
使用环境温度/Usage ambient temperture	-25°C - +70°C
螺钉类型/Screw-thread	M4
扭矩/Tightening torque	1.2-1.5 Nm

未标注公差参照GB/T14486

基本尺寸	0-3	>3-6	>6-10	>10-14	>14-18	>18-24	>24-30	>30-40	>40-50	>50-65	>65-80	>80-100	>100-120	>120-140
公差	±0.08	±0.09	±0.10	±0.12	±0.14	±0.16	±0.18	±0.21	±0.24	±0.28	±0.32	±0.36	±0.41	±0.46

	Rev. 02	Name
单位/Unit mm		3163XX 跨接桥 3163XX Jumper bridge