



## SPECIFICATIONS

1. THIS SPECIFICATIONS APPLY TO EC12E2420404 ROTARY ENCODERS.

2. CONTENTS OF THIS SPECIFICATIONS.

4LE212-8  
LE21203

3. MARKING

• MARKING ON ALL UNITS  
DATE CODE

4. REMARKS

• NOTES

• Marking ⇒ in specifications shows standard and condition for application.

• CAUTION

Regardless of the suggested applications of these products being introduced in the specifications, when using them for equipment and devices requiring a high degree of safety, respective manufacturers will please preserve safety of the planned equipment and devices by providing necessary protective circuits and redundancy circuits and reconfirm if safety is being duly preserved.

Products being introduced in the specifications have been designed and manufactured for applications to ordinary electronic equipment and devices such as the AV equipment, electric home appliances, office machines and communications equipment. Consequently, when employing these products for applications requiring a high degree of safety and reliability such as the medical equipment, aviation and aircraft equipment, space equipment and burglar alarm equipment, the using manufacturers will please thoroughly study the proprieties of these products for the planned applications.

Although we are exerting our best efforts to maintain the quality of these products, we cannot guarantee that they will never cause short circuiting and open circuitry. Therefore, when designing an equipment or device with which the priority is given to the safety, you will please carefully study the influences to the whole equipment of a single function failure of Potentiometers and Encoders in advance to make out a fail-safe design providing.

1. 一般事項 General

1-1 適用範囲 Scope

この仕様書は主として電子機器に用いる微小電流回路用12形薄形ロータリーエンコーダに適用する。  
This specification applies to 12mm size low-profile rotary encoder (incremental type) for microscopic current circuits, used in electronic equipment.

1-2 標準状態 Standard atmospheric conditions

測定は特に指定のない限り、次の状態で行なう。  
Unless otherwise specified, the standard range of atmospheric conditions for making measurements and tests is as follows:

- 温度 Ambient temperature : 15°C to 35°C
- 相対湿度 Relative humidity : 25% to 85%
- 気圧 Air pressure : 86kPa to 106kPa

但し、疑義を生じた場合は、次の基準状態で行なう。

If there is any doubt about the results, measurements shall be made within the following limits:

- 温度 Ambient temperature : 20 ± 1°C
- 相対湿度 Relative humidity : 63% to 67%
- 気圧 Air pressure : 86kPa to 106kPa

1-3 使用温度範囲

Operating temperature range : -10°C to +70°C

1-4 保存温度範囲

Storage temperature range : -40°C to +85°C

2. 構造 Construction

2-1 寸法 Dimensions

添付組立図による。  
Refer to attached drawings.

3. 定格 Rating

3-1 定格電圧

Rated voltage : D. C. 5V

3-2 定格電流 (抵抗負荷)

operating current (resistive load)

- 各リード Each lead : 0.5mA (MAX 5mA, MIN 0.5mA)
- コモンリード Common lead : 1mA (MAX 10mA, MIN 0.5mA)

					 <b>ALPS ELECTRIC CO., LTD.</b>			
					APPD.	CHKD.	DSGD.	TITLE
					1-G4	1-G4	1-G4	ROTATIONAL ENCODER
					K.	H.	Y. KANZAKI	回転形エンコーダ
					Kawasaki	Shimomura		DOCUMENT NO.
SYMB	DATE	APPD	CHKD	DSGD	'97/12/19	'97/12/19	'97/12/19	4LE212-8 (1/8)

4. 電気的性能 Electrical characteristics

項目 Item	条件 Conditions	規格 Specifications													
4-1 出力信号 Output signal format	<p>&lt;Fig 1&gt;</p> <table border="1"> <thead> <tr> <th>軸回転方向 Shaft rotational direction</th> <th>信号 Signal</th> <th>出力波形 Output</th> </tr> </thead> <tbody> <tr> <td rowspan="2">時計方向 C. W.</td> <td>A (A-C端子間) A (Terminal A-C)</td> <td>OFF ON</td> </tr> <tr> <td>B (B-C端子間) B (Terminal B-C)</td> <td>OFF ON</td> </tr> <tr> <td rowspan="2">反時計方向 C. C. W.</td> <td>A (A-C端子間) A (Terminal A-C)</td> <td>OFF ON</td> </tr> <tr> <td>B (B-C端子間) B (Terminal B-C)</td> <td>OFF ON</td> </tr> </tbody> </table>	軸回転方向 Shaft rotational direction	信号 Signal	出力波形 Output	時計方向 C. W.	A (A-C端子間) A (Terminal A-C)	OFF ON	B (B-C端子間) B (Terminal B-C)	OFF ON	反時計方向 C. C. W.	A (A-C端子間) A (Terminal A-C)	OFF ON	B (B-C端子間) B (Terminal B-C)	OFF ON	<p>A, B2信号の位相差出力とし、詳細は&lt;fig. 1&gt;の通りとする。 クリック付きの場合クリック位置にてA信号は出力OFFの安定位置にあることB信号は規定せず。(破線はクリック付きの場合のクリック位置を示す。 2 Phase-different signals (SignalA, signalB) Details shown in &lt;fig. 1&gt;. The detent position will always be aligned with A-phase but B-phase has no specific position. (The broken line shows detent position of with-detent type.)</p>
軸回転方向 Shaft rotational direction	信号 Signal	出力波形 Output													
時計方向 C. W.	A (A-C端子間) A (Terminal A-C)	OFF ON													
	B (B-C端子間) B (Terminal B-C)	OFF ON													
反時計方向 C. C. W.	A (A-C端子間) A (Terminal A-C)	OFF ON													
	B (B-C端子間) B (Terminal B-C)	OFF ON													
4-2 分解能 Resolution	1回転にて出力されるパルス数 Number of pulses in 360° rotation.	各相 24パルス/360° 24 pulses/360° for each phase													
4-3 スイッチング特性 Switching characteristics	<p>下記測定回路&lt;fig. 2&gt;を用い、回転軸を360°・S<sup>-1</sup>の速で回転し測定する。 Measurement shall be made under the condition as follows. 1) Shaft rotational speed : 360°・S<sup>-1</sup> 2) Test circuit : &lt;fig. 2&gt;</p> <p>&lt;fig. 2&gt;</p> <p>&lt;fig. 3&gt;</p> <p>(注記) コードON状態 : 出力電圧が1.5V以下の状態を言う。 コードOFF状態 : 出力電圧が3.5V以上の状態を言う。 (note) Code-ON area : The area which the voltage is 1.5V or less. code-OFF area : The area which the voltage is 3.5V or more.</p>	<p>1) チャタリング Chattering</p> <p>コードのOFF→ON及びON→OFFの際、出力1.5V~3.5Vの通過時間にて規定する。 Specified by the signal's passage time from 3.5V to 1.5V or from 1.5V to 3.5V of each switching position (code OFF→ON or ON→OFF).</p> <p><math>t_1, t_3 \leq 3ms</math></p>													



					<b>ALPS ELECTRIC CO., LTD.</b>				
					APPD. 1-G4 K. Kawasaki	CHKD. 1-G4 H. Shimomura	DSGD. 1-G4 Y. KANZAKI	TITLE ROTATIONAL ENCODER 回転形エンコーダ	
SYMB	DATE	APPD	CHKD	DSGD	'97/12/19	'97/12/19	'97/12/19	4LE212-8 (2/8)	

項目 Item	条件 Conditions	規格 Specifications
2) 揺動ノイズ (バウンス) Sliding noise (Bounce)	コードONの部分の1.5V以上の電圧変動時間とし、チャタリング $t_1$ , $t_3$ 両者との間に1mS以上の1.5V以下のON部分を有するものとする。また、揺動ノイズ間に1.5V以下の範囲が1mSある場合は、別の揺動ノイズと判断する。 Specified by the time of voltage change exceed 1.5V in code-ON area. When the bounce has code-ON time less than 1mS between chattering ( $t_1$ or $t_3$ ), the voltage change shall be regarded as a part of chattering. When the code-ON time between 2 bounces is less than 1mS, they are regarded as 1 linked bounce.	$t_2 \leq 2mS$
3) 揺動ノイズ Sliding noise	コードOFFの部分の電圧変動 The voltage change in code-OFF area.	3.5V以上 3.5V MIN.
4-4 耐電圧 Dielectric strength	端子-取付板間にA. C. 50V1分間印加する。(リーク電流1mA) A voltage of 50V A.C. shall be applied for 1min between individual terminals and bracket. (Leak current 1mA)	絶縁破壊のないこと。 Without arcing or breakdown.
4-5 絶縁抵抗 Insulation resistance	端子-取付板間にD. C. 50V印加する。 Measurement shall be made under the condition which a voltage of 50V D.C. is applied between individual terminals and bracket.	端子-取付板間にて10MΩ以上 Between individual terminals and bracket: 10MΩ MIN.
4-6 位相差 Phase-difference	定速で操作軸を回転する。 Measurement shall be made under the condition which the shaft is rotated in constant speed.  <fig. 4> 時計方向 CW A信号 (A-C間) Signal A B信号 (B-C間) Signal B  反時計方向 CCW A信号 (A-C間) Signal A B信号 (B-C間) Signal B	<fig. 4>において $\Delta T = 0.08T$ 以上 MIN In <fig. 4>

					<b>ALPS ELECTRIC CO., LTD.</b>	
APPD. 1-G4 K. Kawasaki			CHKD. 1-G4 H. Shimomura		DSGD. 1-G4 Y. KANZAKI	
					TITLE ROTATIONAL ENCODER 回転形エンコーダ	
					DOCUMENT NO. 4LE212-8 (3/8)	
SYMB	DATE	APPD	CHKD	DSGD		

5. 機械的性能 Mechanical characteristics

項目 Item	条件 Conditions	規格 Specifications
5-1 全回転角度 Total rotational angle		360° (エンドレス) 360° (Endless)
5-2 クリックトルク Detent torque	(クリック付きのみ適用) (Applied for with-detent type)	3 ~ 20 mN・m  但し、-10°C~+5°Cでは、軸が回転すること。 Shaft rotatable at -10°C~+5°C.
5-3 クリック点数及び位置 Number and position of detents.	(クリック付きのみ適用) (Applied for with-detent type)	24点クリック 24 detents (ステップ角度 15°±3°) (Step angle:15°±3°)
5-4 軸の押し引き強度 Push-pull strength of shaft	軸の押し及び引き方向に80Nの静荷重を10秒間加える。(PCB半田付け後) Push and pull static load of 80N shall be applied to the shaft in the axial direction for 10S. (After soldering of the PC board)	軸の破損、著しい回転ムラ、ガタ等の異常がなく電気的性能を満足すること。 Without damage to, or excessive play in shaft. No excessive abnormality in rotational feeling. And electrical characteristics shall be satisfied.
5-5 端子強度 Terminal strength	端子先端の任意の方向に3Nの静荷重を10秒間加える。 A static load of 3N shall be applied to the tip of terminals for 10S in any direction.	著しいガタ及び接触不良を生じないこと。 Without excessive play in terminals or poor contact.
5-6 軸ガタ Shaft wobble	 軸先端から5mmの位置に50mN・mの曲げモーメントを加える。 A momentary load of 50mN・m shall be applied at the point 5mm from the tip of the shaft in a direction perpendicular to the axis of shaft.	0.7×L/30mmφ-D以内 0.7×L/30mmφ-p MAX. (Lは取付長さで比例計算する。) (l:Shaft length)
5-7 軸のスラスト方向ガタ Shaft play in axial direction	軸に3Nの押し引き荷重を加える。 Push and pull static load of 3N shall be applied to the shaft in the axial directions.	0.4mmφ-D以内 0.4mmφ-p MAX.
5-8 軸の垂直押し強度 Side thrust strength of shaft	軸先端から5mmの位置に20Nの静荷重を10秒間加える。(PCB半田付け後) A load of 20N shall be applied at the point 5mm from the tip of the shaft in a direction perpendicular to the axis of shaft. (After soldering of the PC board)	著しいガタ及び、曲がりのないこと。 又、機械的に異常のないこと。 Without excessive play or bending in shaft. No mechanical abnormality.
5-9 軸の回転方向ガタ Shaft play in rotational wobble	角度板にて測定する。 Measure with jig for rotational angle	3°以内。 3° MAX

					 <b>ALPS ELECTRIC CO., LTD.</b>			
		APPD.	CHKD.	DSGD.	TITLE ROTATIONAL ENCODER 回転形エンコーダ			
		1-64	1-64	1-64				
		K. Kawasaki	H. Shimomura	Y. KANZAKI	DOCUMENT NO.			
 1	99/7/21	K. K. I. Y. K.			4LE212-8 (4/8)			
SYMB	DATE	APPD	CHKD	DSGD	'97/12/19	'97/12/19	'97/12/19	

	項目 Item	条 件 Conditions	規 格 Specifications
5-10	はんだ耐熱 Resistance to soldering heat	7項の「はんだ付け条件」による。 Specified by the clause 7 "Soldering conditions".	<p>はんだ付け後、電気的性能を満足すること。また、著しい方寸等機械的異常のないこと。</p> <p>Electrical characteristics shall be satisfied. No mechanical abnormality such as a excessive play.</p> <p>電極部ははんだ浸漬面積の95%以上新しいはんだで覆れていること。</p> <p>A new uniform coating of solder shall cover a minimum of 95% of the surface being immersed.</p>

					 <b>ALPS ELECTRIC CO., LTD.</b>			
					APPD.	CHKD.	DSGD.	TITLE ROTATIONAL ENCODER
					1-64	1-64	1-64	回転形エンコーダ
					K. Kawasaki	H. Shimomura	Y. KANZAKI	DOCUMENT NO.
SYMB	DATE	APPD	CHKD	DSGD	' 97/12/19	' 97/12/19	' 97/12/19	4LE212-8 (5/8)

6. 耐久性能 Endurance characteristics.

項目 Item	条件 Conditions	規格 Specifications
6-1 しゅう動寿命性能 Rotational life	無負荷で軸を600~1000/Hの速で、30,000回往復回転断続動作を行う。 The shaft of encoder shall be rotated to 30,000 cycles at a speed of 600~1000/H without electrical load, after which measurements shall be made.	チャタリング $t_1, t_2 \leq 5\text{ms}$ バウンス $t_2 \leq 3\text{ms}$ Chattering $t_1, t_2 \leq 5\text{ms}$ Bounce $t_2 \leq 3\text{ms}$ クリック感が残っていること。 (クリック付きのみ適用) Detent feeling has to remain. (Applied for detent type)
6-2 耐湿性 Damp heat	温度 $40 \pm 2^\circ\text{C}$ 、湿度90~95%の恒温湿槽中 $240 \pm 10$ 時間放置後、常温、常湿中 $1.5$ 時間放置する。 The encoder shall be stored at a temperature of $40 \pm 2^\circ\text{C}$ with relative humidity of 90% to 95% for $240 \pm 10\text{H}$ in a thermostatic chamber. And then the encoder shall be subjected to standard atmospheric conditions for 1.5H, after which measurement shall be made.	初期規格を満足すること。 Specifications in clause 4.1~4.5 and 5.1~5.3 shall be satisfied
6-3 耐熱特性 Dry heat	温度 $85 \pm 3^\circ\text{C}$ の恒温槽中 $240 \pm 10$ 時間放置後、常温、常湿中 $1.5$ 時間放置する。 The encoder shall be stored at a temperature of $85 \pm 3^\circ\text{C}$ for $240 \pm 10\text{H}$ in a thermostatic chamber. And then the encoder shall be subjected to standard atmospheric conditions for 1.5H, after which measurements shall be made.	初期規格を満足すること。 Specifications in clause 4.1~4.5 and 5.1~5.3 shall be satisfied.
6-4 低温特性 Cold	温度 $-40 \pm 3^\circ\text{C}$ の恒温槽中 $240 \pm 10$ 時間放置後、常温、常湿中 $1.5$ 時間放置する。 The encoder shall be stored at a temperature of $-40 \pm 3^\circ\text{C}$ for $240 \pm 10\text{H}$ in a thermostatic chamber. And then the encoder shall be subjected to standard atmospheric conditions for 1.5H, after which measurement shall be made.	初期規格を満足すること。 Specifications in clause 4.1~4.5 and 5.1~5.3 shall be satisfied.
6-5 耐落下性 Free falling	60cmの高さより製品の任意の方向からビニタイルを張ったコンクリートの床上に自由に落下させる。 The encoder shall be fallen freely at any posture from 60cm height to the concrete floor covered with vinyl-tile, after which measurement shall be made.	著しい変形、破壊等がなく初期規格を満足すること。 (但し、端子部の変形は除く。) No excessive deformation or damage. (Except the deformation of terminals.) And specifications in clause 4.1~4.5 and 5.1~5.3 shall be satisfied.
6-6 耐振性 Vibration	10~55~10HZと変化する振動(1周期1分/振幅1.5mm)をX、Y、Z、各方向に2時間加える。 The following vibration shall be applied to the encoder, after which measurement shall be made: The entire frequency range, from 10HZ to 55HZ and return to 10Hz, shall be transversed in 1 min. Amplitude(total excursion): 1.5mm. This motion shall be applied for a period of 2H in each of 3 mutually perpendicular axes (A total of 6H).	初期規格を満足すること。 Specifications in clause 4.1~4.5 and 5.1~5.3 shall be satisfied.

					 <b>ALPS ELECTRIC CO., LTD.</b>		
		APPD.	CHKD.	DSGD.	TITLE ROTATIONAL ENCODER		
		1-64	1-64	1-64	回転形エンコーダ		
		K.	H.	Y. KANZAKI	DOCUMENT NO.		
		Kawasaki	Shimomura		4LE212-8 (6/8)		
SYMB	DATE	APPD	CHKD	DSGD			
		'97/12/19	'97/12/19	'97/12/19			



7. はんだ付け条件 Soldering conditions

7-1 手はんだの場合 Manual soldering

温度300°C以下、時間3秒以内

Bit temperature of soldering iron : 300°C or less.

Application time of soldering iron : within 3s.

7-2 デイップはんだの場合 Dip soldering

使用基板 : t1. 6片面銅張り基板

Printed wiring board: Single-sided copper clad laminate board with thickness of 1.6mm.

フラックス : 比重0.82以上のフラックスを用い発泡式フラクサーにて発泡面高さは、基板板厚の半分を目安とし、かつ基板表面にフラックスの流入がないこと。

Flux:

・Specific gravity: 0.82 or more.

・Flux shall be applied to the board using a bubble foaming type fluxer.

・The board shall be soaked in the flux bubble only to the middle of its thickness.

・Flux shall not come into contact with the component side surface.

プリヒート : 基板表面温度100°C以下、時間1分以内

Preheating:

・Surface temperature of board: 100°C or less.

・Preheating time: within 1 min.

はんだ : 温度260°C±5°C、時間3秒±1秒以内

Soldering:

・Solder temperature: 260°C ±5°C.

・Immersion time: Within 3±1s

以上の工程を1回または2回通過する。

Apply the above soldering process for 1 or 2 times.

8. はんだ付け時のご注意事項 Note for soldering method.

8-1 下図のようにP. C. B. の上面にはんだ付けをする配線は、お避けください。

Please avoid soldering on upper surface (the component side surface) of the PC board as shown below.

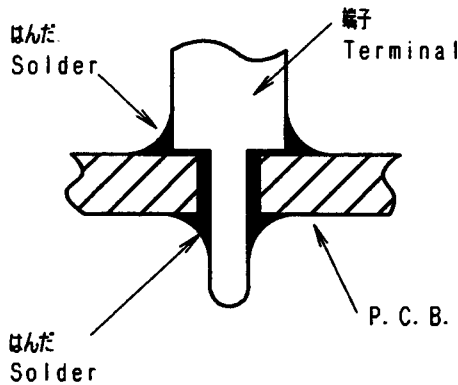

8-2 半田テ ィップ° 後の洗浄についてはエンコータ° 内にフラックスが流入する場合があります。接触不良の原因となりますのでご注意ください。

Please avoid cleaning of PCB board because the flux used during the dip soldering process may enter the encoder and cause poor contact

					<b>ALPS ELECTRIC CO., LTD.</b>			
					APPD.	CHKD.	DSGD.	TITLE
					1-G4	1-G4	1-G4	ROTATIONAL ENCODER
					K.	H.	Y. KANZAKI	回転形エンコーダ
					Kawasaki	Shimomura		DOCUMENT NO.
					'97/12/19	'97/12/19	'97/12/19	4LE212-8 (7/8)
SYMB	DATE	APPD	CHKD	DSGD				

9. その他、取扱い上のご注意 PRECAUTIONS IN USE

9-1. 保管は高温、多湿の場所及び腐食性ガス中を避けて下さい。

During operation, storage in high temperature and humidity, and in corrosive gas, should be avoided.

9-2. エンコータのハルスカウント処理の設計においては動作スピード、サンプリングタイム、マスキングタイム等注意し、実装確認の上御使用願います。

⚠ In case of pulse count process design, operational speed, sampling time, and masking time etc should be taken into the consideration. Please check above matter at first on your circuit for the secure reason.

9-3. 本製品はクリック位置にてA相はOFF状態で安定となりますので、ソフト設計時A相基準で設計願います。

⚠ A phase should be design criterion prior to B phase. Because A phase has steady off signal at detent position.

9-4. エンコータのハルスカウント処理の回路は下図のフィルターをいれることを推奨します。

⚠ For your pulse count design, it should be considered to add C/R filter on your circuit shown as below.

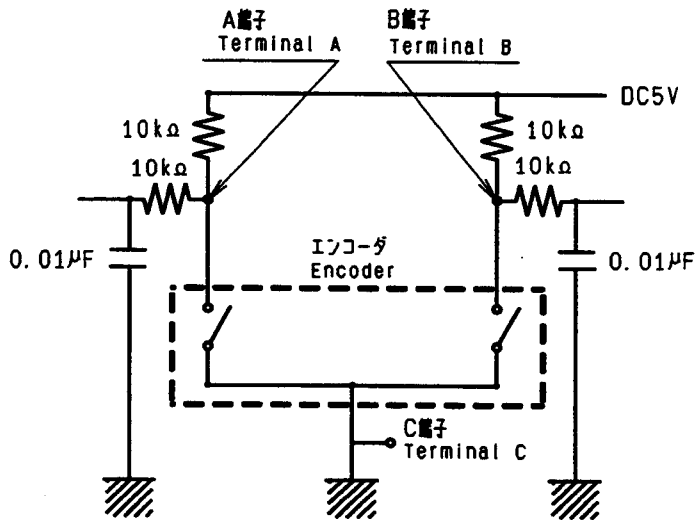

9-5. 本製品の本体に直接水分がかかると、ハルス波形に異常が発生する可能性がありますので、製品に直接水分がかからないよう配慮願います。

Care must be taken not to expose this product to water or dew to prevent possible problem in pulse output wave form.

9-6. 医療用機械、器具への本製品の御使用は御避け下さい。

Please avoid to medical instrument because this encoder is audio use.

					<b>ALPS ELECTRIC CO., LTD.</b>			
					APPD. 1-G4 K. Kawasaki	CHKD. 1-G4 H. Shimomura	DSGD. 1-G4 Y. KANZAKI	TITLE ROTATIONAL ENCODER 回転形エンコーダ
					DOCUMENT NO.			
					4LE212-8 (8/8)			
SYMB	DATE	APPD	CHKD	DSGD	'97/12/19	'97/12/19	'97/12/19	

この間は $\phi 6-0.05$   
WITHIN THIS LENGTH

商標の位置は任意  
THE DIRECTION OF  
TRADE MARK IS OPTIONAL

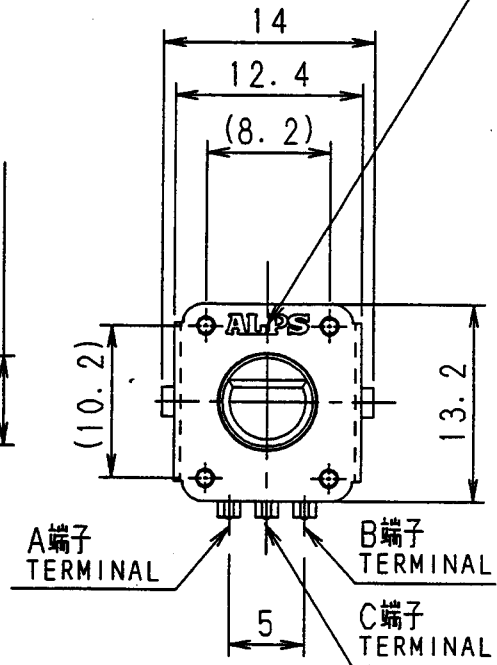
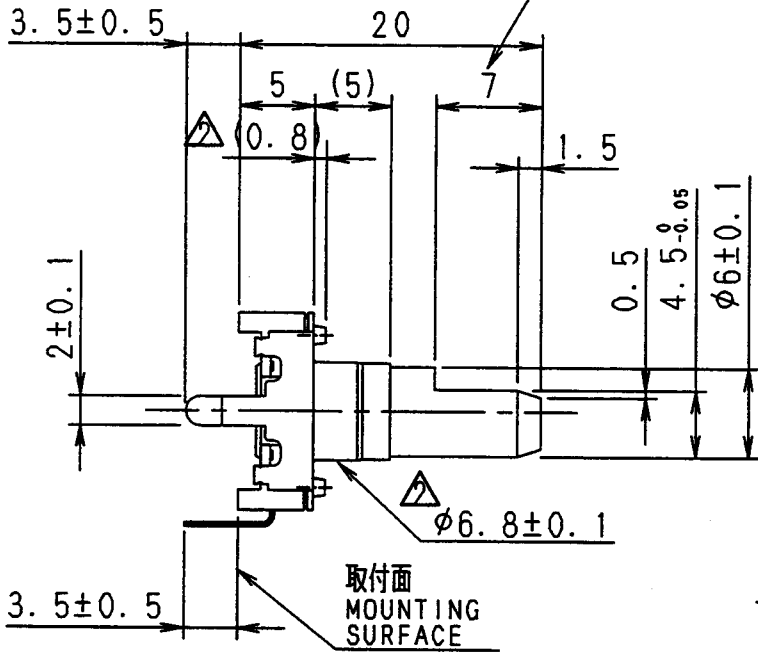

取付穴寸法図 (許容差 $\pm 0.1$ )

\*挿入側より見た図  
P. W. B. MOUNTING DETAIL  
(TOLERANCE $\pm 0.1$ )  
VIEWED FROM MOUNTING SIDE

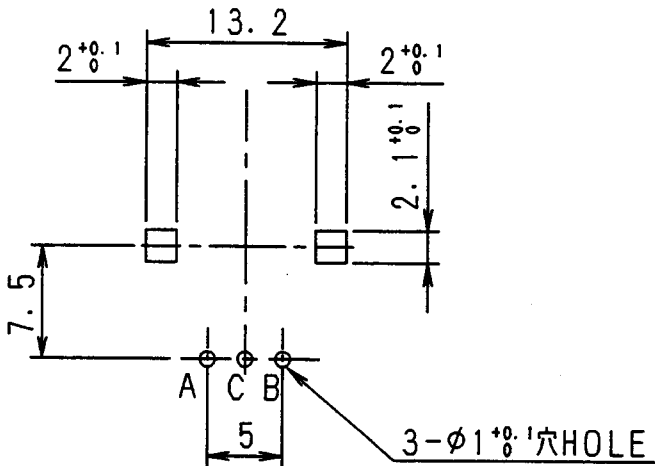

基板板厚  $t = 1.6\text{mm}$   
P. C. B.

端子先端詳細図 (10:1)

△ DETAIL OF TERMINALS

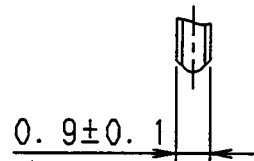

指定なき部分の許容差 TOLERANCES UNLESS OTHERWISE SPEC	
$L \leq 10$	$\pm 0.3$
$10 < L < 100$	$\pm 0.5$
$100 \leq L$	$\pm 0.8$
角度 ANGULAR DIMENSION	$\pm 5^\circ$



24パルス 24PLUSE  
SHAFT COLOR: BLACK  
L=20  
伏形 クリック付

PART NO.	NAME	MATERIAL NAME / CODE	FINISH
<b>ALPS ELECTRIC CO., LTD.</b>			
△ 1	99/12/14 K. IY. KH. O	DSGD. セツケイ1-8502781 Y. KANZAKI 97-08-20	SCALE 2:1 NO. _____
△ 1	99/8/21 K. KK. IY. K	CHKD. H. SHIMOMURA 97-08-20	TITLE 12形薄形エンコーダ -
△ 1	97/9/04 白石 川崎 神崎	APPD. K. KAWASAKI 97-08-20	UNIT m m DOCUMENT NO. LE21203
初設	97/4/16 川崎 下村 神崎		
SYMB	DATE	APPD	CHKD

