

Lithium manganese battery N0532, CR2477, electrode VFY 2, external mining, air transportation

Undeclared tolerance	sign	date	Description of shanges	to bear
Basic dimensions	Tolerance range			
0.0-0.5	±0.05			
5.0-10.0	±0.08			
> 10.0	±0.13			

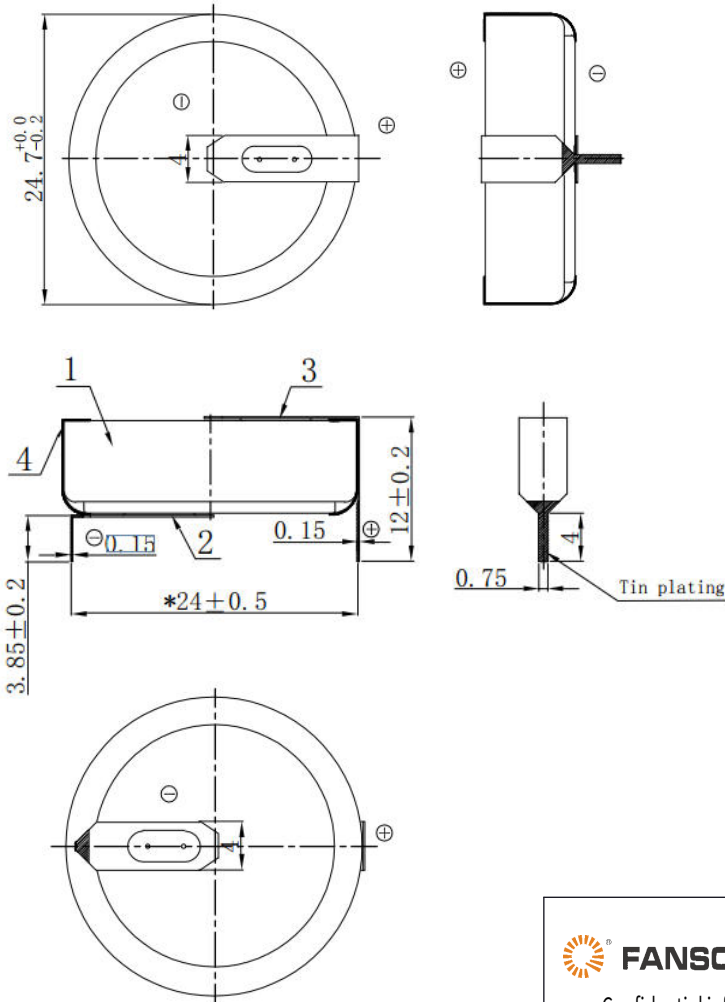

客户回签 Customer signature	
公司名称 Company name	
批准人 Approved by	
签字 (盖章) 日期 Signature date	

密级：AA

外发文件 受控文件  
外发编号:FAT-W-20240923001

4	Sleeve	Yellow PVC	1	
3	soldering lug	Bills, 25 * 4 * 12 * 0.15, SUS430 tin nickel	1	
2	soldering lug	Bills, 15.4 * 4 * 3.85 * 0.15, SUS430 tin nickel	1	
1	Cell	CR2477	1	
NO.	MATERIAL	SPECIFICATION	QTY	MARK

Technical requirements

- Nominal voltage  $\geq 3.0V$ .
- The battery shall be free of leakage,damage and dirt.
- Environmental protection requirements: comply with our Environmental Control Standard FAT-PZ-GL-QT-022.

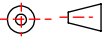
 <b>FANSO</b> Wuhan FANSO Technology co.,Ltd Confidential information of FANSO, no spreading without permission!				Machine	N0532			The part name	finished product	
design		technique	Kang Changzhou	drawing number	FAT-JF-BZCR- 05577 A0			Material number	91016205	
drawing	Zhu Xue ping	quality	Yang Kai	Material				version	A0	View orientation
audit	Zhu Zhi gang	approval	Liu Peng	Stage markers	F	C	Z	D	S	
standard	Zhu Zhi gang	date	2024.09.22	date						unit mm
				The first one-one in total			Weight	Proportion		size A4